



WATER PUMP

OWNER'S MANUAL

Read this manual carefully before operation

CHONGQING ZONGSHEN GENERAL POWER MACHINE CO.,LTD

THE PEOPLE'S REPUBLIC OF CHINA

CONTENTS

Notice	1
1. Overview	2
2. Components & Principle	3
3. Safety Instruction	5
4. Specifications	7
5. Operation	9
6. Maintenance & Servicing	19
7. Trouble Shooting	24
8. Transportation & Storage	25
9. Unpacking	26
10. Warranty	27

Notice

Read this manual carefully before operation.

All rights reserved. Copy or transcribe this manual or any part of this manual is strict prohibited without written authorization.

Please pay attention to the following safety labels that indicates personal safety is required.



: WARNING indicates death, personal injury and/or property damage may occur if instructions are not followed carefully.



: CAUTION indicates personal injury and/or property damage might occur if instructions are not followed carefully.



- This manual is a part of the pump and should be transferred with the pump if the proprietorship is changed.

- The figures in this manual are for operation reference only and they may not as exactly same as the productions

1. Overview

Thank you for buying the pump(s). You are not ready to operate the pump without read this manual carefully.

This manual applies to the series of the pumps which designed for transfer water with a temperature under 40°C.

Characteristics of these centrifugal pumps: axis side sucking, semiclosed impeller or closed impeller, single or multiple stage, volute chamber, outlet upwards, quick coupling, mechanical seal, counter-clockwise rotate from inlet side.

The manual shall be subject to any changes due to continuous improvement and/or generation changes without additional notices and the company will not bear any responsibility for that reason.



- This centrifugal pump will give you completely trouble free and satisfactory service only on the condition that it is installed and operated with due care and is properly maintained.

2. Components & Principle

1. Components

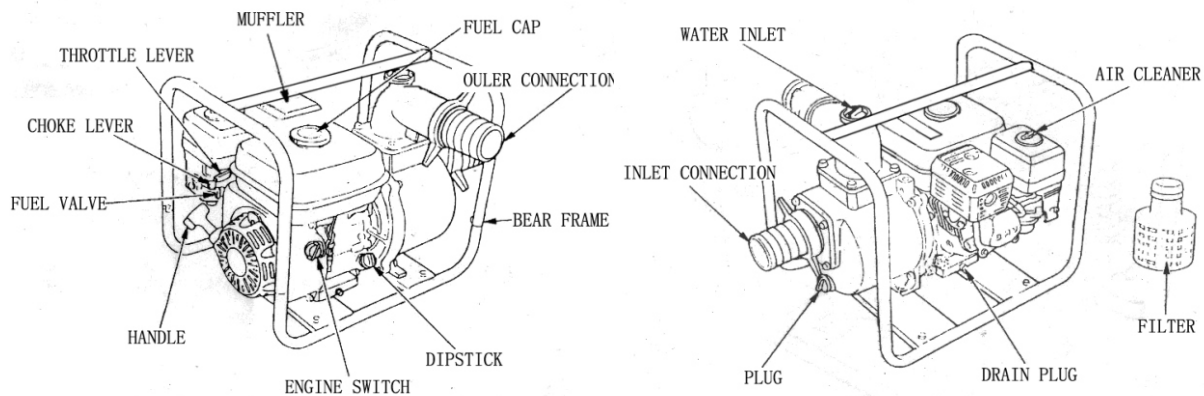

Fig. 1

2. Principle

The centrifugal pump works by the conversion of the rotational energy from the engine to a water pressure. The rotation of the pump impeller imparts kinetic energy to the water as it is drawn in from the impeller eye (centre) and is forced outward through the impeller vanes to the periphery. As the water exits the impeller, the water kinetic energy is then converted to pressure due to the change in area the water experiences in the volute section. The energy conversion results in an increased pressure on the downstream side of the pump, causing flow.

3. Model classification (QGZ50-32 as example)

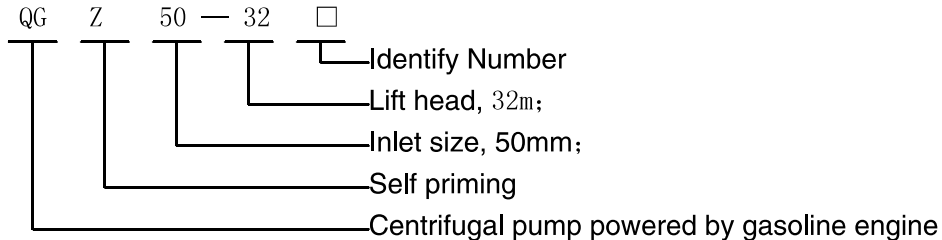

Fig. 2

3. Safety Instruction



- DO NOT operate the pump if you are not feeling good to prevent any personal injury and/or property damage.
- For you safety, do not apply this pump for the flammable and/or corrosive liquids such as gasoline, alcohol, seawater and so on, except that pump QGZ50-25, QGZ50-30 can be applied for the fluid which has a PH value between 4 and 11.
- Plastic parts of this pump touch oil is not recommend.
- Always place the pump at a level solid ground to avoid fuel leak.
- Operate pump at a ventilative place and keep 1m away from the wall or other equipment.
- Only authorized and skilled operation is allowed
- Gasoline is highly flammable and explosive, only refill at a ventilative place and keep flammable matters away. Do not over fill.
- Stop engine before refilling (fuel and oil).
- Wipe up spilled fuel after refilling.

WATER PUMP OWNER'S MANUAL

• The engine/pump can be seriously damaged without oil. Always check oil level before using. Do not start engine without adequate oil. The engine must stand on level ground when checking.



For personal safety, please pay attention to the following labels:



• DO NOT touch hot muffler, cylinder and other hot parts which can cause burns.



• Before use, carefully read this manual. Follow all safety warnings.



• Always stop engine and/or allow engine to cool before fill fuel while engine is hot or running. Do not refuel in an unventilated area.



• Exhaust gases contain carbon monoxide, an odorless and deadly poison. Do not use indoors.

4. Specifications

Table 1 Specifications

Item	Pump model					
	QGZ50-25	QGZ50-30	QGZ80-30	QGZ50-32	QGZ40-55	QGZ100-30
Inlet/outlet size (mm)	50/50	50/50	80/80	50/50	40/40	100/100
Flow at specified point (m ³ /h)	18	22	38	25	12	40
Lift at specified point (m)	17	20	10	17.5	39	15
Self priming lift (m)	5	5	5	5	5	5
Self priming time(s)	160	160	160	160	160	160
Engine model	168F/P-A、165F/P		168F/P-B、170F/P			177F/P
Engine power (kW)	3.2		3.8			5.8
RPM (r/min)	3600		3000	3600		

WATER PUMP OWNER'S MANUAL

Table 1 (cont.)

Item	Pump model						
	QGZ40-75	QGZ50-65	QG50-63	QG65-55	QG50-70	QGZ50-100	QGZ80-80
Inlet/outlet size (mm)	40/40	50/50	50/50	65/50	50/50	50/50	80/65
Flow at specified point (m ³ /h)	8	20	15	20	20	20	24
Lift at specified point (m)	47	38	38	30	40	63	50
Self priming lift (m)	5	5	-	-	-	5	5
Self priming time(s)	160	160	-	-	-	160	160
Engine model	168F/P-B、170F/P				182F/P	188F/P	
Engine power (kW)	3.8				6.8	7.4	
RPM (r/min)	3600						

5. Operation

1. Before Operation

1.1 Connect inlet pipe to the pump

Use joint to connect inlet pipe to the pump, and tight it by hoop.

The inlet pipe must be a non-folding pipe and not longer than the required length. A shorter pipe you have, a better pump performance you get. Also the self priming time is proportional to the inlet pipe length.

The filter should be assembled to the inlet of the pipe. See figure 3.

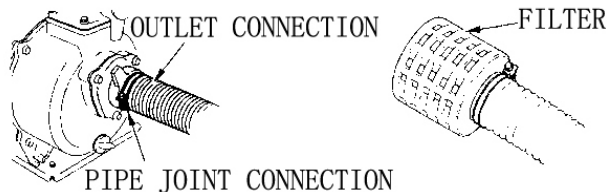

Fig.3



- Always operate the pump with filter to prevent pump block or impeller damage.

- Leakage from the pipe or joint will reduce self-priming or other performance. Keep joint and hoop be tightened.

1.2 Connect outlet pipe to the pump

Use joint to connect outlet pipe to the pump, and tight it by hoop.

A short pipe with large diameter is the best choice. Long pipe or small diameter pipe will increase flowed friction and thus lose pump power.



- In case of pipe burst, a outlet pipe which can experience a pressure higher than the maximum pressure of the pump is required.

1.3 Check oil level.



- No fuel and oil in engine. Fill fuel and oil before using.
 - a. Remove dipstick and clean it.
 - b. Insert the dipstick into oil filler neck, but do not screw it in, then remove it out and check oil level.
 - c. If oil level is near or below the lower limit marked on the dipstick, remove dipstick, and fill with the recommended oil to the upper limit (bottom edge of the oil fill hole). Do not overfill.

d. Reinstall dipstick.

⚠ CAUTION

- Do not overfill.
- Oil is a major factor affecting performance and service life. Use 4-stroke automotive detergent oil. The applicable oil grade depends on the ambient temperature. Please prepare accordingly. SAE 10W-30 is recommended for general use.

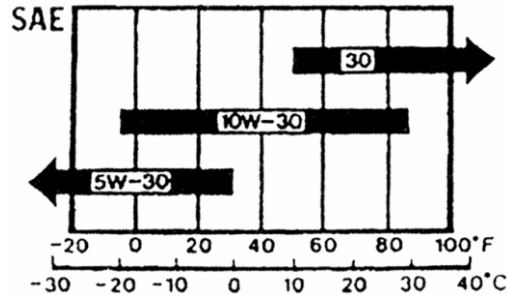

Fig.4

⚠ WARNING

- The engine can be seriously damaged without oil. Always check oil level before using. The

engine must stand on level ground while checking.

1.4 Check fuel level.

- a. Remove the fuel cap.
- b. Add unleaded gasoline to the fuel level limit if necessary. 90# gasoline is recommended for general use.
- c. Wipe up spilled fuel and reinstall the cap tightly.

CAUTION

- Do not overfill.
- Leaded gasoline or unclean gasoline will increase deposition in engine block and shorten engine life.

WARNING

Gasoline is highly flammable and explosive, you can be burned or seriously injured during refueling.

Stop engine and keep heat, sparks, and flame away.

Refuel only outdoors.

Gasoline is poisonous, be careful not to touch it or inbreathe its vapor.

1.5 Check air filter

- a. Remove air filter cover. Be careful to prevent dirt falling into air filter base.
- b. Remove air filter from air filter base.
- d. Inspect the filter element(s). Cleaning or replace it if necessary. See figure 5.
- e. Reinstall filter element(s) and cover

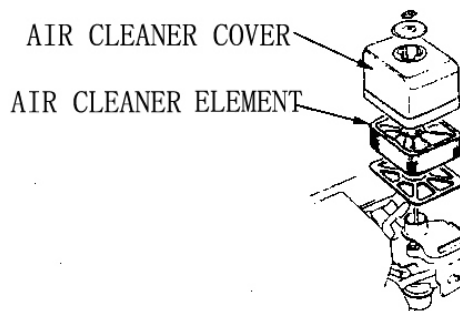

Fig. 5



WARNING

- Do not start and operate engine without air filter otherwise dirt will go into cylinder through carburetor and result in engine damage.

1.6 Check/infuse water

Infuse water to pump chamber before start engine. A self-priming pump can be started only with full of water. See figure 6.



- Run the pump without water inside will cause over heat and seal damage.
- If the water in the pump chamber is sucked over, stop engine immediately, Allow engine cool and then infuse water again.

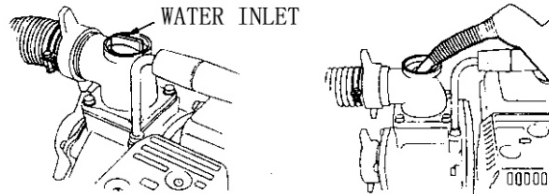

Fig.6

2. Operation

- (1) Open fuel valve.
- (2) Close choke.



- Do not use choke if engine is warm or the temperature is high. See figure 7.

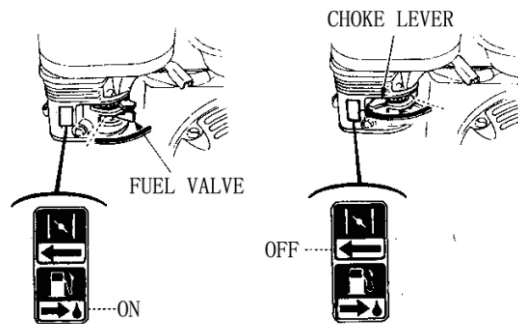

Fig. 7

- (3) Set engine switch to "ON". See figure 8.

ENGINE SWITCH

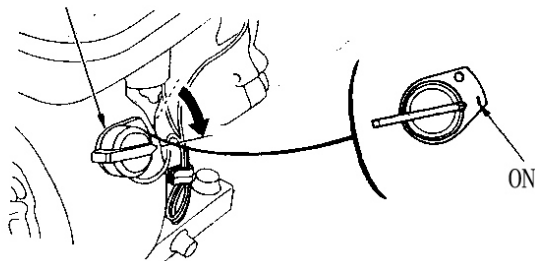

Fig. 8

(4) Move throttle lever to left side. See figure 9

THROTTLE LEVER

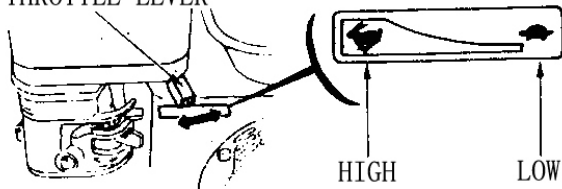

Fig. 9

(5) Pull starter handle lightly until you feel resistance, then pull quickly.

CAUTION

- Do not allow the starter handle to snap back against the engine. Return it gently.
- (6) After engine warm up, open the choke gradually. See figure 10.

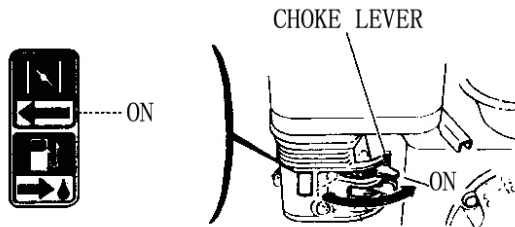

Fig. 10

- (7) Adjust throttle lever to achieve the rated speed.

WARNING

- Do not refill while engine is running.

WATER PUMP OWNER'S MANUAL

- Wipe up spilled fuel before start engine.

3. Stop Engine/After Use

- (1) Move throttle lever to right side.
- (2) Set engine switch to “OFF”. See figure 11.

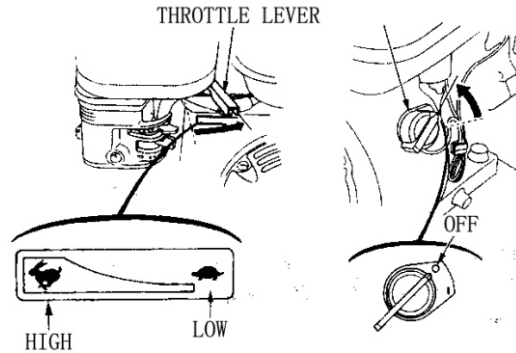

Fig. 11

- (3) Close fuel valve.



- Turn the engine switch to “OFF” immediately IN AN EMERGENCY..

6. Maintenance & Servicing

For maintain your pump performance, a scheduled check and adjustment is required. And scheduled maintenance will extend pump life.



- Before any repair and maintenance, make sure that the pump is stopped.
 - If the pump has applied to any other fluid rather than water, apply to clean water for a short while to clean pump before repair or maintenance.
1. Replace oil.

Replace oil after initial 20 hours or the first month operation, whichever is applicable.

Oil can be drain thoroughly when engine is still hot.

Remove oil drain bolt and drain oil. Replace with new oil. See figure 12.



- Do not overfill.
- Wash hands with soap after oil replacement.

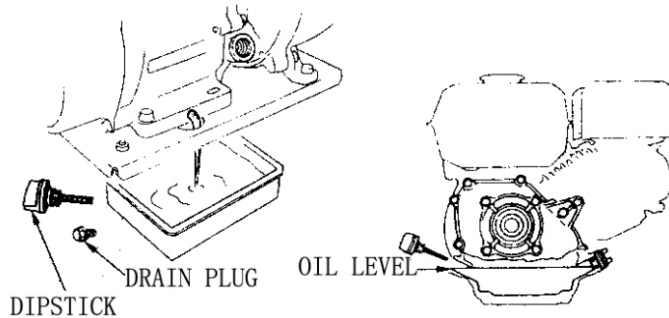

Fig. 12

2. Maintenance of air filter

A dirty air filter will cut down air flow and cause carburetor block. Please pay attention to the scheduled maintenance of the air filter.

- a. Unscrew butterfly nut and then remove filter cover and element.
- b. Clean the element with the solution which has a high fire point and non-flammable character and then dry it.
- c. Soak the element with engine oil and then squeezes unwanted oil.

d. Reassembly the element and cover.



- Do not start and operate engine without air filter otherwise dirt will go into cylinder through carburetor and cause engine damage.

3. Maintenance of Spark Plug

In order to ensure the normal performance of the engine, check spark plug clearance timely.

- 1) Remove spark plug cap.
- 2) Clean dirt around spark plug base.
- 3) Remove spark plug.
- 4) Inspect the spark plug. Clean the spark plug with wire brush. If the insulator is cracked or ragged, replace it accordingly.
- 5) Measure the spark plug clearance with gauge. The clearance should be 0.6~0.8mm. If necessary, bend the outside electrode and adjust it to required clearance. See figure 13.



(1) remove spark plug

(2) clean carbon laydown

(3) adjust clearance

Fig. 13

6) Install the spark plug by hand, and note that the screw is not tightened.

7) After installed a new spark plug by hand, tighten it 1/2 circle by wrench (1/8 to 1/4 circle for a used spark plug). See figure 14.

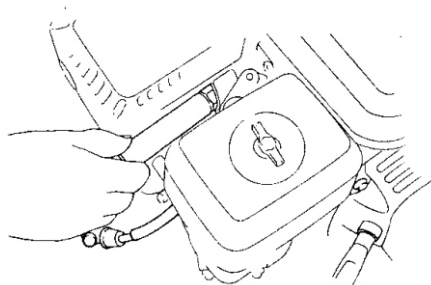

Fig. 14

 CAUTION

- 9) Reinstall the spark plug cap.
- 10) Reinstall the spark plug service cover.

 CAUTION

- Spark plug must be fixed tight.
- Don't use a incorrect heat rating spark plug.

7. Trouble Shooting

1. Engine won't start.

1.1 Make sure engine switch is "ON"

1.2 Check fuel level

1.3 Fuel valve is "ON"

1.4 Has fuel reaches carburetor?



- Wipe up spilled fuel before start engine.

1.5 Check oil level

1.6 Remove spark plug and check if there has sparks. Adjust the gap or replace spark plug if necessary.

1.7 Send generator to the dealer or authorized service center if you need help.

2. Pump has no function.

2.1 Water infused?

2.2 Filter blocked?

2.3 Pipe leak? (cracking, loosing hoop, bad seal)

2.4 Over self priming height?

8. Transportation & Storage



- Allow engine cool before transportation or storage.

Turn fuel switch to “OFF” position and fasten pump on a level surface during transportation to reduce the possibility of fuel leak

If the pump will be stored for a long time, the following items are recommended.

1. Clean pump including the impeller in case of any mud, sand or other chips keep inside.
2. Empty fuel tank and carburetor bowl.
2. Start the engine and let it run until it stops due to lack of fuel.
3. Change engine oil if it will be stored longer than 3 months.
4. Remove the spark plug and empty a little engine oil (about 30 ml) in the hole. Crank the engine a couple of times. Reinstall spark plug.
5. Clean pump thoroughly.
6. Lubricate all the parts outside if necessary.

7. Inspect pump for damage and repair it if necessary.
8. Rust protection to the metal surfaces.
9. Store the pump indoors and cover it if possible.



- Pump seals will lose function after 12 months. Check and replace it if reaches that time.

9. Unpacking

When unpacking:

- Do not turn upside down and handle with care !
- Package list, certificate, warranty card and owner's manual are packed inside. Check if all goods are comply with package list.
- Contact local dealer or service/repair center when you have questions. And you can call service hotline for help also.

10. Warranty

Dear consumer:

Thank you for choosing the production. According to the Law of the People's Republic of China on the Protection of Consumers' Rights and Interests, The company must warranty following service upon you provide the receipts and warranty card.

1. The warranty period is one year.
2. The company will repair your engine at no cost to you including diagnosis, parts and labor within warranty period if you ensure the performance of all scheduled maintenance.
3. Subject to following conditions, The company will not bear any cost including diagnosis, parts and labor. We provide timeless toll maintenance service for your convenience.
 - 1) lack of receipts or warranty card.
 - 2) Damaged due to sudden factors or Improper use (including, without limitation, transit, hit, improper fuel).
 - 3) Self-repair without admission.
 - 4) Information showing on the warranty card doesn't conform to the engine.
 - 5) warranty period has expired.



ChongQing ZongShen General Power Machine Co., Ltd.

Address: Zongshen Industry Zone, Chongqing 400054, China

Phone: 023—66372549 Fax: 023—66372586

Hot Line: 4007003088 023—66372519

Execution Standard: JB/T7731.2-1995; JB/T8688-1998

Engine Production License NO.: XK06—002—00110

http: //www.zongshenmotor.com

The first edition/April, 2009

The first impression/April, 2009

158#