

GALLIGNANI

Presse raccoglitrici
Presses ramasseuses
Pick-up balers

1500 - 1600

1690 - 2690

2690E - 3690

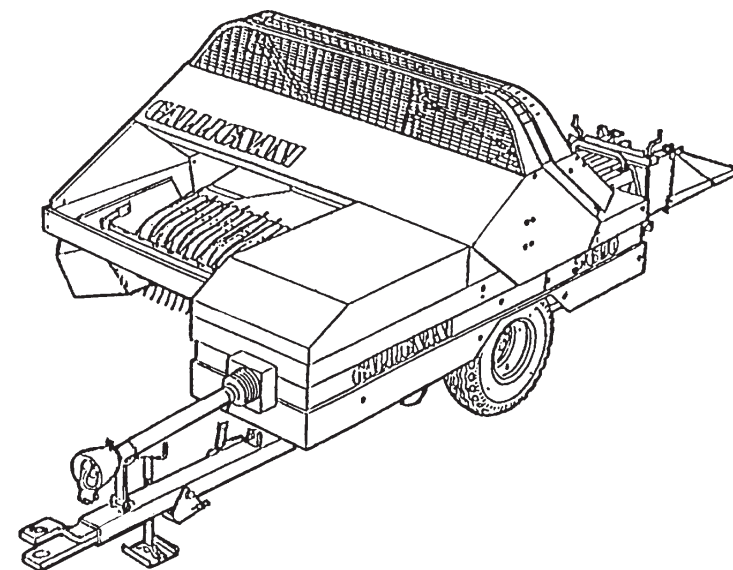

IDM - esperti in comunicazione tecnica • FO 217.009 Ed.5

**catalogo parti di ricambio
pièce s de rechange
spare parts list**

Annulla e sostituisce
Annule et remplace
Cancels and replace

N. 98.09.086

5

01-10-01

N. 98.09.097

**PER ORDINARE PARTI DI RICAMBIO
OCCORRE INDICARE:**

- Tipo della macchina
- Numero del telaio
- Matricola del pezzo
- Quantità dei pezzi desiderati

Le voci - destro
- sinistro
- anteriore
- posteriore

si riferiscono alla direzione di lavoro della macchina.

Le descrizioni e illustrazioni si intendono fornite a titolo indicativo e non impegnativo.

**POUR COMMANDER DES PIÈCES DE
RECHANGE VEUILLEZ INDIQUER:**

- Type de la machine
- Numéro de châssis
- Numéro de la pièce
- Quantité de pièces désirée

Les termes - droit
- gauche
- antérieur
- postérieur

se rapportent à la direction de marche de la machine.

Les descriptions et illustrations sont donnés à titre indicatif et sans engagement.



**WHEN ORDERING SPARE PARTS WILL
YOU PLEASE MENTION:**

- Model of machine
- Number of chassis
- Part number
- Quantity

The terms - right
- left
- front
- rear

refer to direction of travel of the machine.

The descriptions and illustrations serve merely as an indication and are not binding.

	SIMBOLI CONVENZIONALI	SIGNES CODIFIES	CONVENTIONAL SIGNS
	Fino al telaio N	Jusdu'au chassis N	Up to chassis Nr
	A partire dal telaio N	A partir de chassis N	From chassis Nr
	Dal telaio N. al N.....	De chassis N..... à N.....	From chassis Nrto Nr.....
45 44 002	Pezzi forniti insieme	Pièces fournies ensemble	Parts supplied together
DES	Destro	Droite	Right
SIN	Sinistro	Gauche	Left
L	Lunghezza	Longueur	Length
Sp	Spessore	Epaisseur	Thickness

A	TELAIO CHASSIS FRAME	TIMONE TIMON DRAWBAR	ASSALE PONT AXLE	ARRESTI FORAGGIO BUTEES FOURRAGE FODDER STOPS	RUOTA DESTRA ROUE DROITE RIGHT WHEEL
	RUOTA SINISTRA ROUE GAUCHE LEFT WHEEL				
B	TRASMISSIONE TRANSMISSION TRANSMISSION	COMANDO RACCOGLITORE COMMANDE DU RAMASSEUR PICK-UP CONTROL			
C	PISTONE PISTON PISTON	GUIDE PER PISTONE GUIDES POUR PISTON GUIDE FOR PISTON			
D	RIDUTTORE REDUCTEUR REDUCTION GEAR	VOLANO VOLANT FLYWHEEL			
E	TELAIO RACCOGLITORE CARCASSE DU RAMASSEUR PICK-UP FRAME	ASPO RACCOGLITORE RABATTEUR RAMASSEUR PICK-UP REEL	SUPPORTI RACCOGLITORE SUPPORTS RAMASSEUR PICK-UP SUPPORTS	DISPOSITIVO DI SOLLEVAMENTO RACCOGLITORE RELEVAGE DU RAMASSEUR PICK-UP POSITION	ALBERO CARDANICO ARBRE À CARDAN CARDAN SHAFT
F	LEGATORE A SPAGO LIEUR A FICELLE TWINE KNOTTER	AGHI E PARTICOLARI PER LEGATORE A SPAGO AIGUILLES ET PIECES POUR LIEUR DE FICELLE NEEDLES AND DETAILS FOR TWINE TYING UNIT		PROTEZIONI PROTECTIONS GUARDS	
G	LEGATORE A FILO DI FERRO LIEUR A FIL DE FER WIRE KNOTTER	AGHI E PARTICOLARI PER LEGATORE A FILO DI FERRO AIGUILLES ET PIECES POUR LIEUR A FIL DE FER NEEDLES AND DETAILS FOR IRON WIRE TYING UNIT		CASSETTA PORTABOBINE CAISSE PORTE-BOBINES SPOOL-HOLDING BOX	
H	GUIDE FORAGGIO GUIDES FOURRAGE FODDER GUIDES	FORCA SINISTRA FOURCHE GAUCHE LEFT FORK	FORCA DESTRA FOURCHE DROITE RIGHT FORK		
L	ALBERO CARDANICO ARBRE À CARDAN CARDAN SHAFT	FRIZIONE EMBRAYAGE CLUTCH			

N	PORTA AGHI PORTE AIGUILLES NEEDLES SUPPORT	SUPPORTO LEGATORE SUPPORTS DE LIEUR KNOTTER SUPPORTS	REGISTRO LUNGHEZZA BALLE REGLAGES DE LONGHEUR DES BALLE BALE ADJUSTMENT	DENTE ARRESTO PISTONE DENT D'ARRET DU PISTON PISTON PAWL
P	PROTEZIONI PROTECTIONS GUARDS	PROTEZIONI RACCOGLITORE PROTECTIONS DU RAMASSEUR PICK-UP PROTECTIONS	PROTEZIONI FORCHE PROTECTIONS DES FOURCHES FORK PROTECTIONS	PROTEZIONI POSTERIORI PROTECTIONS ARRIERE REAR PROTECTIONS
R	DOTAZIONE DOTATION TOOLS	DECALCOMANIE DECALCOMANIES TRANSFERS		
S	LUBRIFICAZIONE PER LEGATORE A SPAGO GRAISSAGE POUR LIEUR DE FICELLE LUBRICATION FOR TWINE TYING UNIT		LUBRIFICAZIONE PER LEGATORE A FILO DI FERRO GRAISSAGE POUR LIEUR A FIL DE FER LUBRICATION FOR IRON WIRE TYING UNIT	RULLO DI SOSTEGNO IN FERRO ROULEAU DE SUPPORT EN FER IRON BEARING ROLLER
	CONTABALLE COMPTEUR DE BALLE BALES COUNTER	RUOTE ROUES WHEELS	ATTACCO TIMONE SNODATO RACCORD TIMON ARTICULE ARTICULATED DRAWBAR CONNECTION	DEFLETTORE PER FORAGGI CORTI DEFLECTEUR POUR FOURRAGES COURTS BAFFLE PLATE FOR SHORT CROPS
	APPARATO FRENANTE DISPOSITIF DE FREINAGE BRAKING SYSTEM	RUOTA GOMMATA SUPPLEMENTARE ROUE EN CAOUTCHOUC SUPPLEMENTAIRE ADDITIONAL RUBBERIZED WHEEL	RUOTINO PER RACCOGLITORE ROULETTE POUR RECOULTEUSE PICK-UP WHEEL	SLITTA SOSTEGNO LATO SINISTRO GLISSIERE DE SUPPORT COTE GAUCHE LEFT SIDE SUPPORTING SLIDE
	PROLUNGA TIMONE RALLONGE TIMON DRAWBAR EXTENSION	SOLLEVAMENTO IDRAULICO RACCOGLITORE RELEVAGE HYDRAULIQUE DU RAMASSEUR PICK-UP HYDRAULIK POSITION	SPOSTAMENTO MECCANICO TIMONE DEPLACEMENT MECANIQUE TIMON DRAWBAR MECHANICAL DISPLACEMENT	
	IMPIANTO ELETTRICO INSTALLATION ELECTRIQUE ELECTRIC SYSTEM	TIMONE E ALBERO SDOPPIATO TIMON ET ARBRE DEDOUBLE DRAWBAR AND SPLIT SHAFT	SPOSTAMENTO IDRAULICO TIMONE DEPORT DU TIMON HYDRAULIQUE HYDRAULIC DRAWBAR ADJUSTMENT	

GALLIGNANI

S.p.A

Via molinaccio, 10
48026 Russi (RA) Italia



0544/589201
FAX 0544/581222



n° 76 - 48026 Russi (RA) Italia

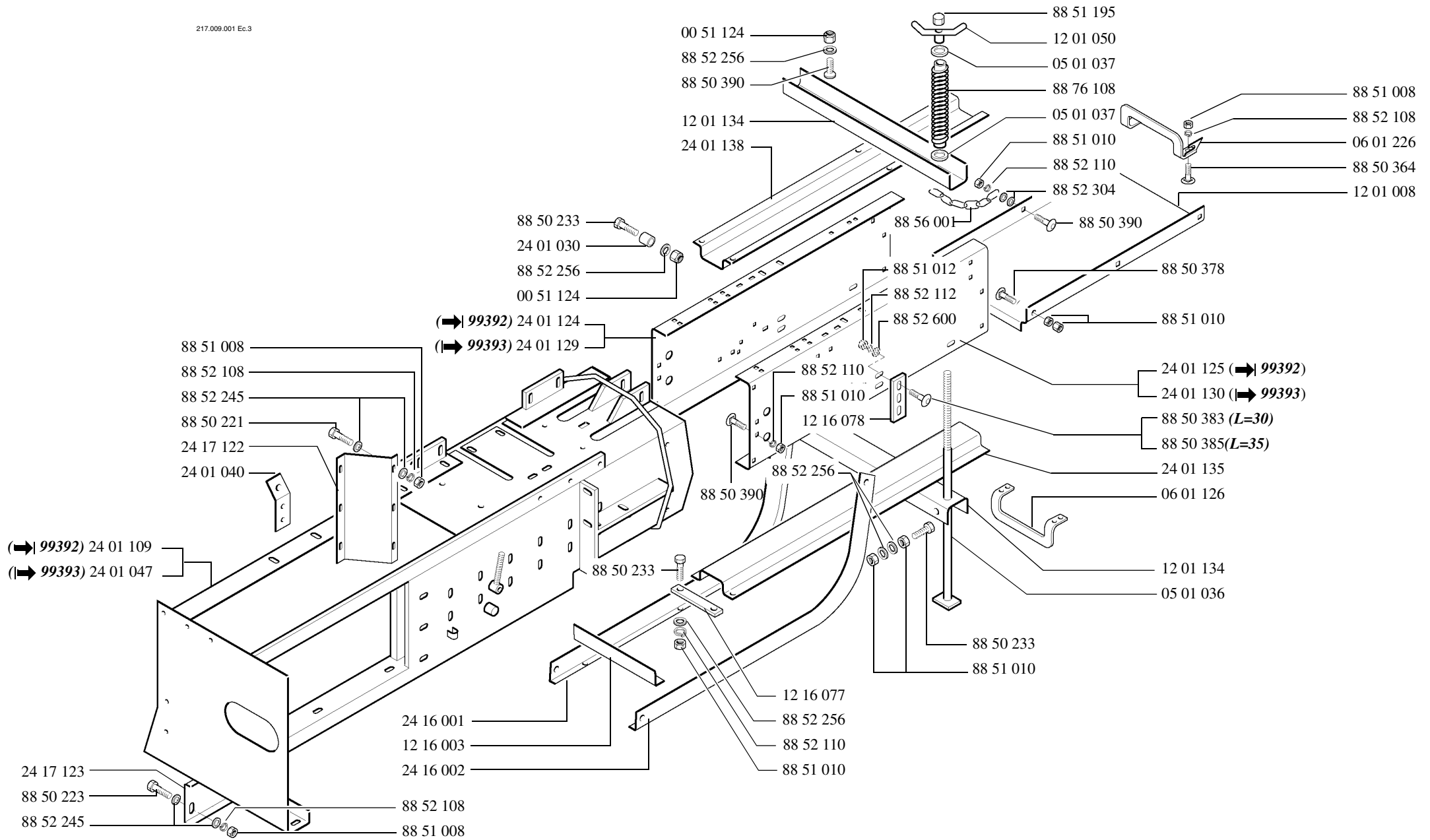

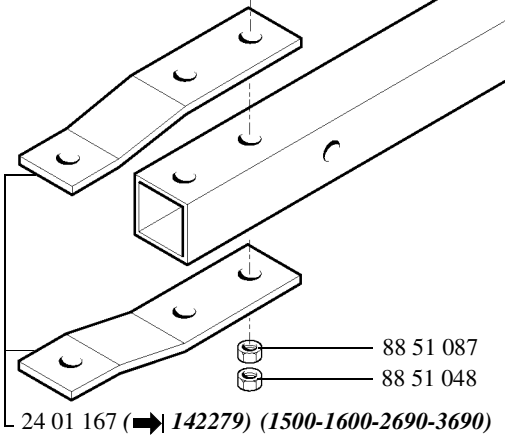
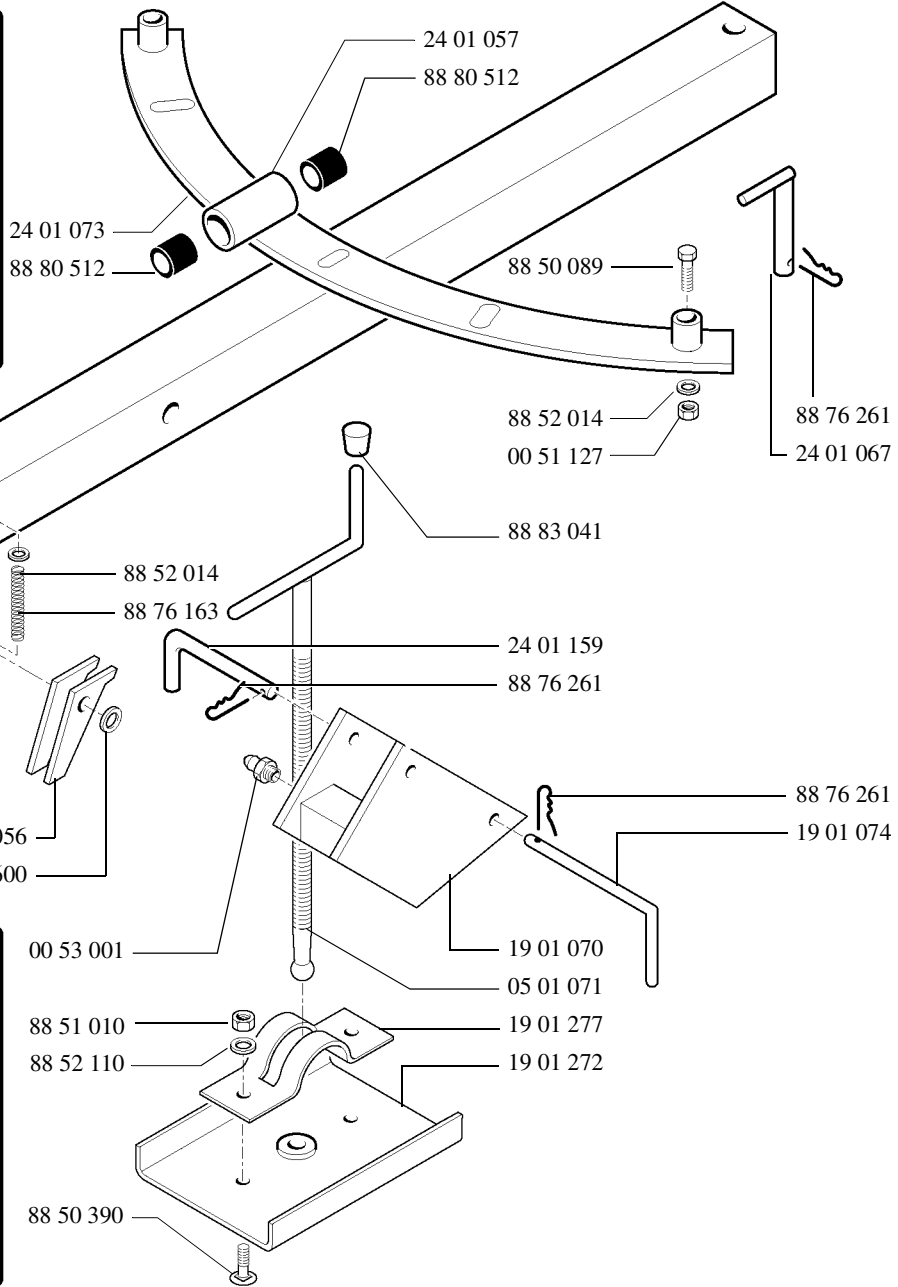
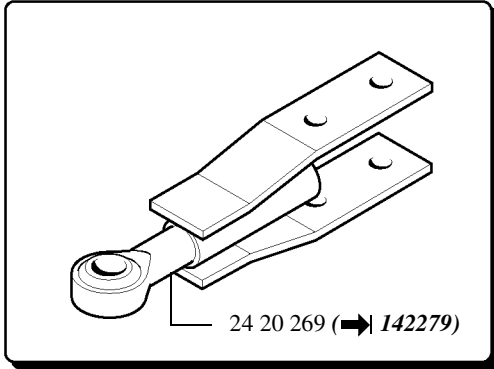
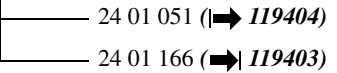
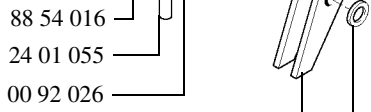
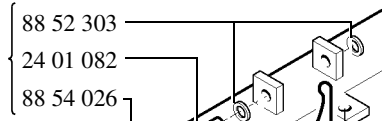
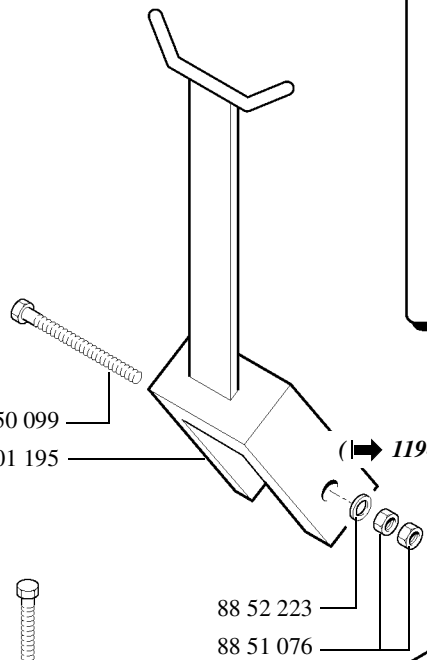
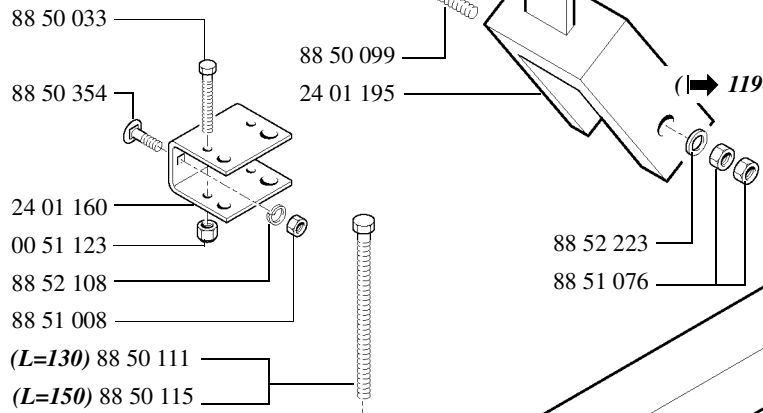
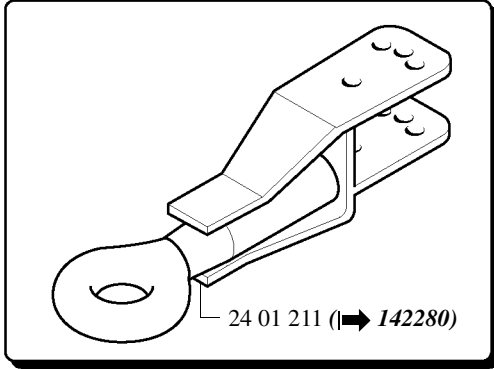
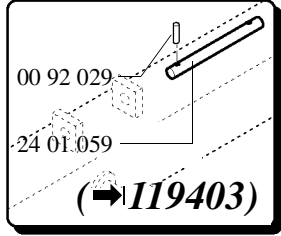

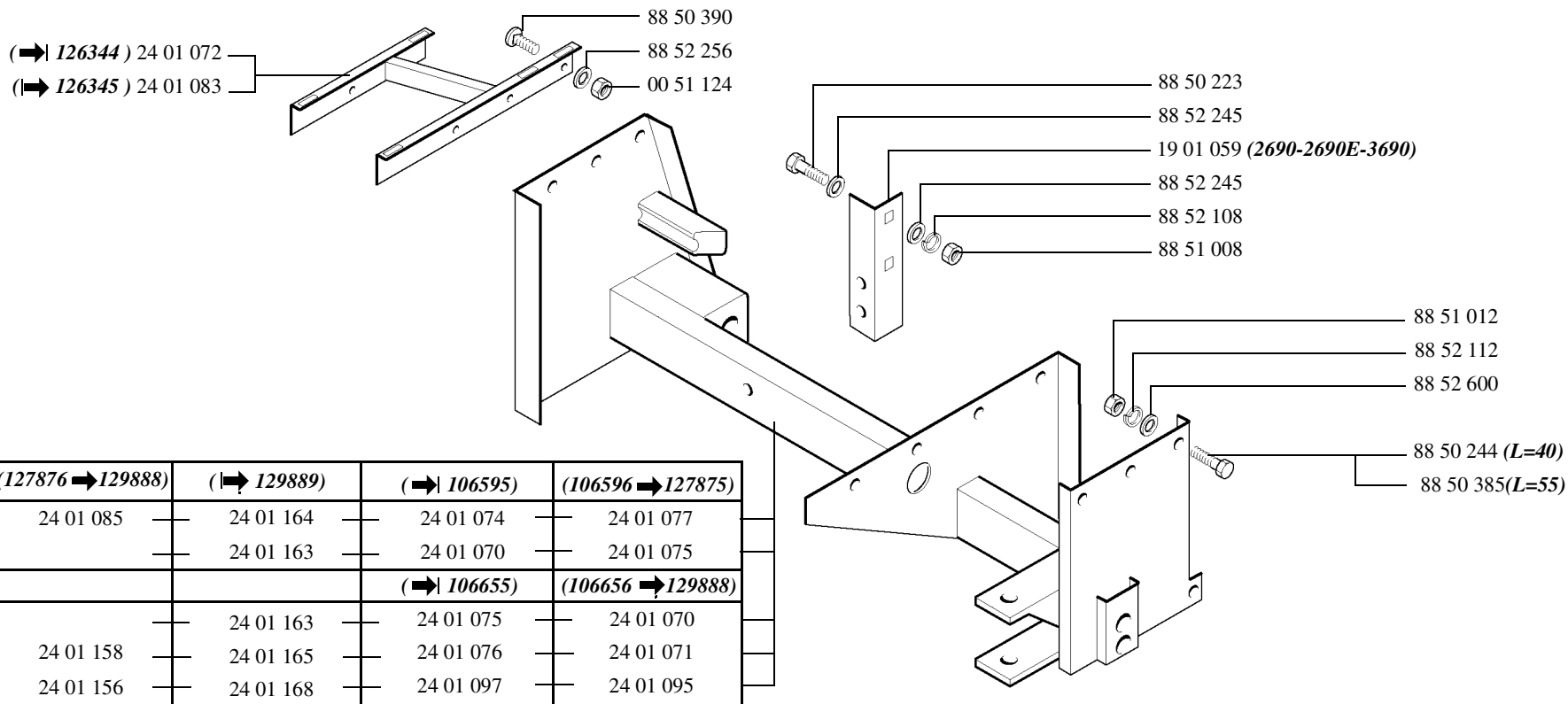

	(127876 → 129888)	(129889)	(106595)	(106596 → 127875)
(1500)	24 01 085	24 01 164	24 01 074	24 01 077
(1600)		24 01 163	24 01 070	24 01 075
			(106655)	(106656 → 129888)
(1690)		24 01 163	24 01 075	24 01 070
(2690)	24 01 158	24 01 165	24 01 076	24 01 071
(2690E-3690)	24 01 156	24 01 168	24 01 097	24 01 095

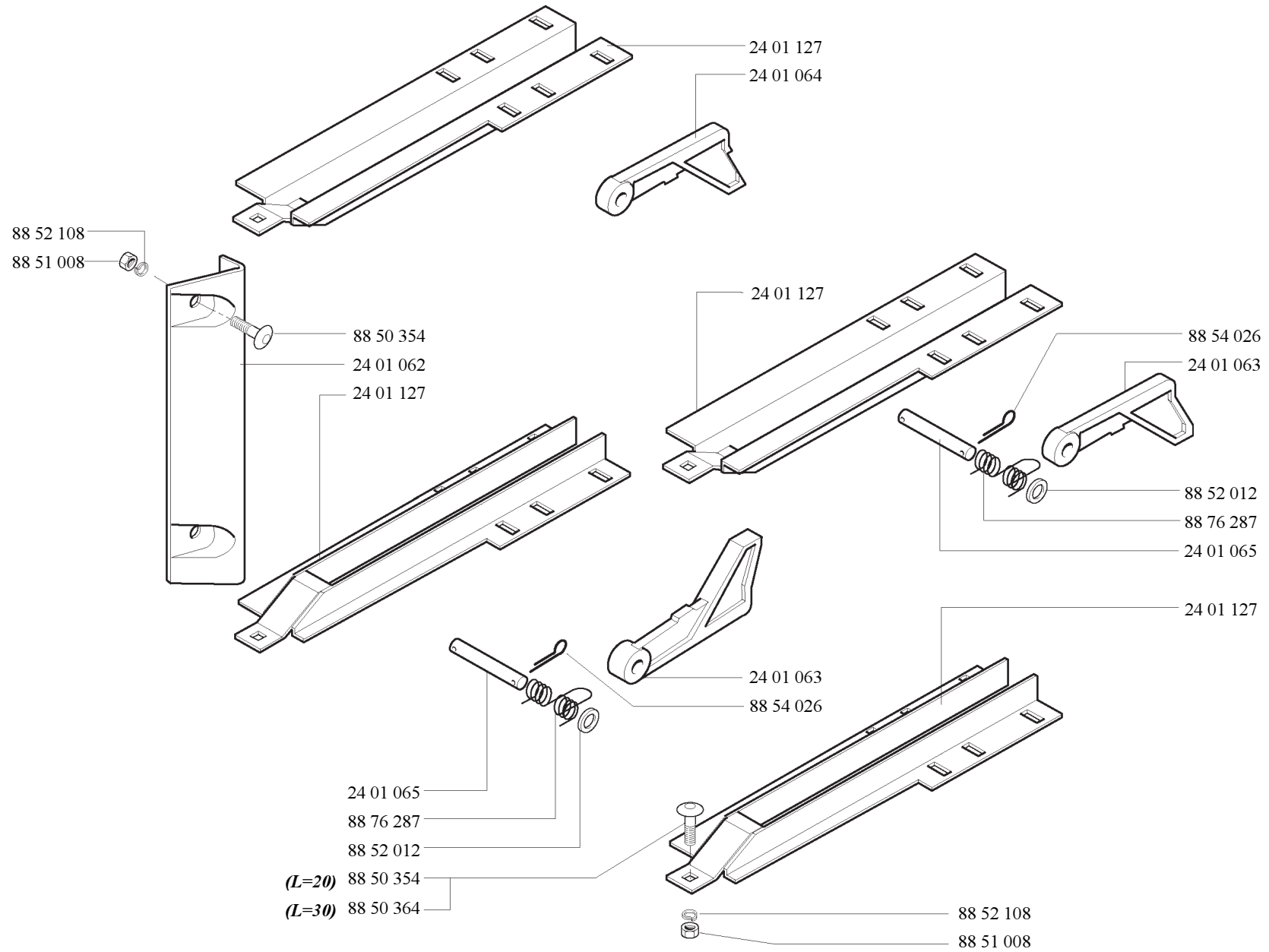

00 51 126

88 50 065

24 44 063

- 24 01 045
- 00 71 028
- 00 70 040
- 88 75 416
- 35 01 830
- 88 75 404
- 00 70 035
- 88 52 025
- 88 54 026
- 88 51 112
- 06 01 282

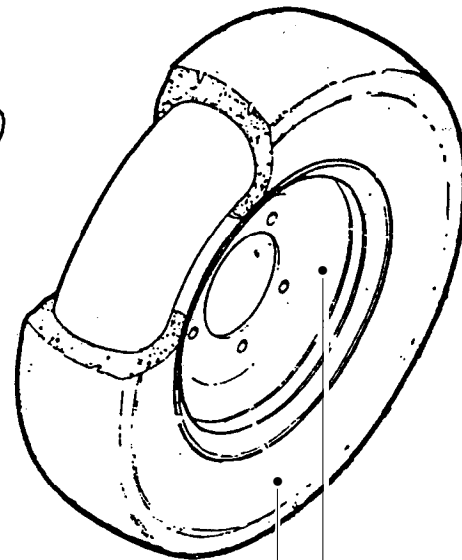
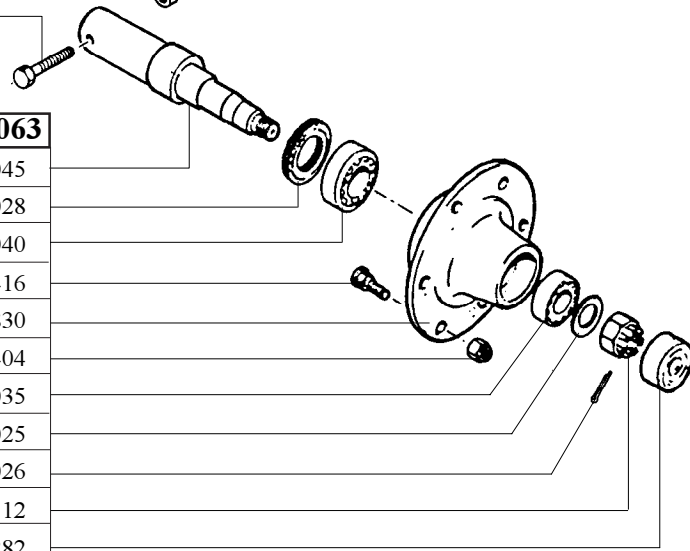

24 44 064

- 88 75 360
- 00 75 172
- 7.00-12"

(**1** → 142280)

00 51 126

88 50 065

24 44 002

- 24 01 045
- 00 71 028
- 00 70 040
- 88 75 416
- 06 01 280
- 88 75 404
- 00 70 035
- 88 52 025
- 88 54 026
- 88 51 112
- 06 01 282

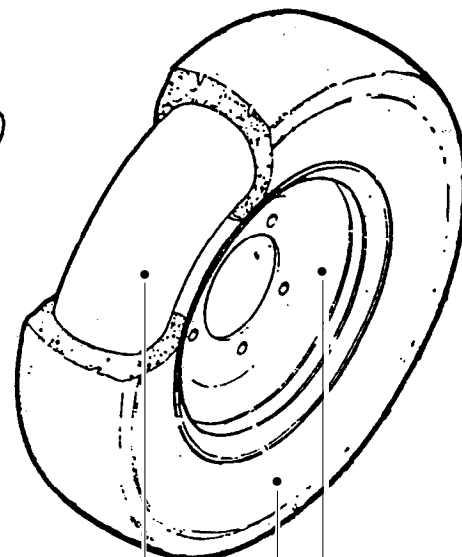
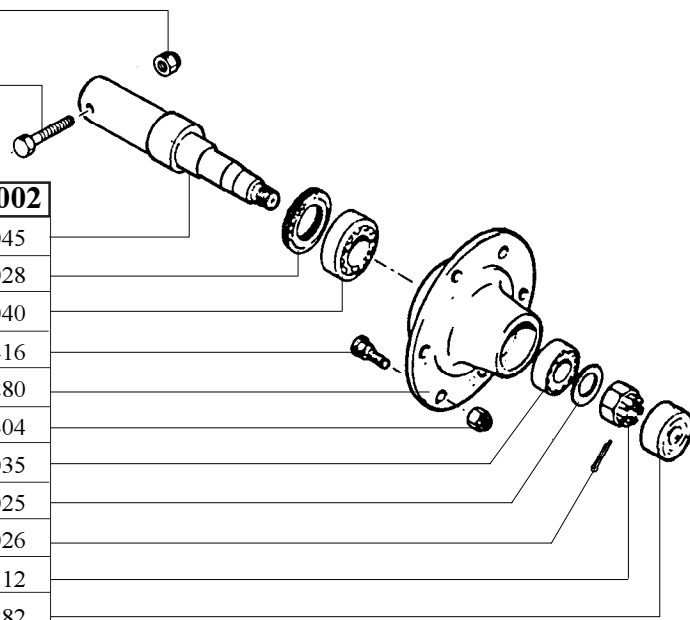

24 44 003

- 88 75 341
- 00 75 142
- 00 75 233

BR-78x14"

24 44 059

- 88 75 341
- 00 75 161
- 00 75 233

185/65-14

(→ 142279)

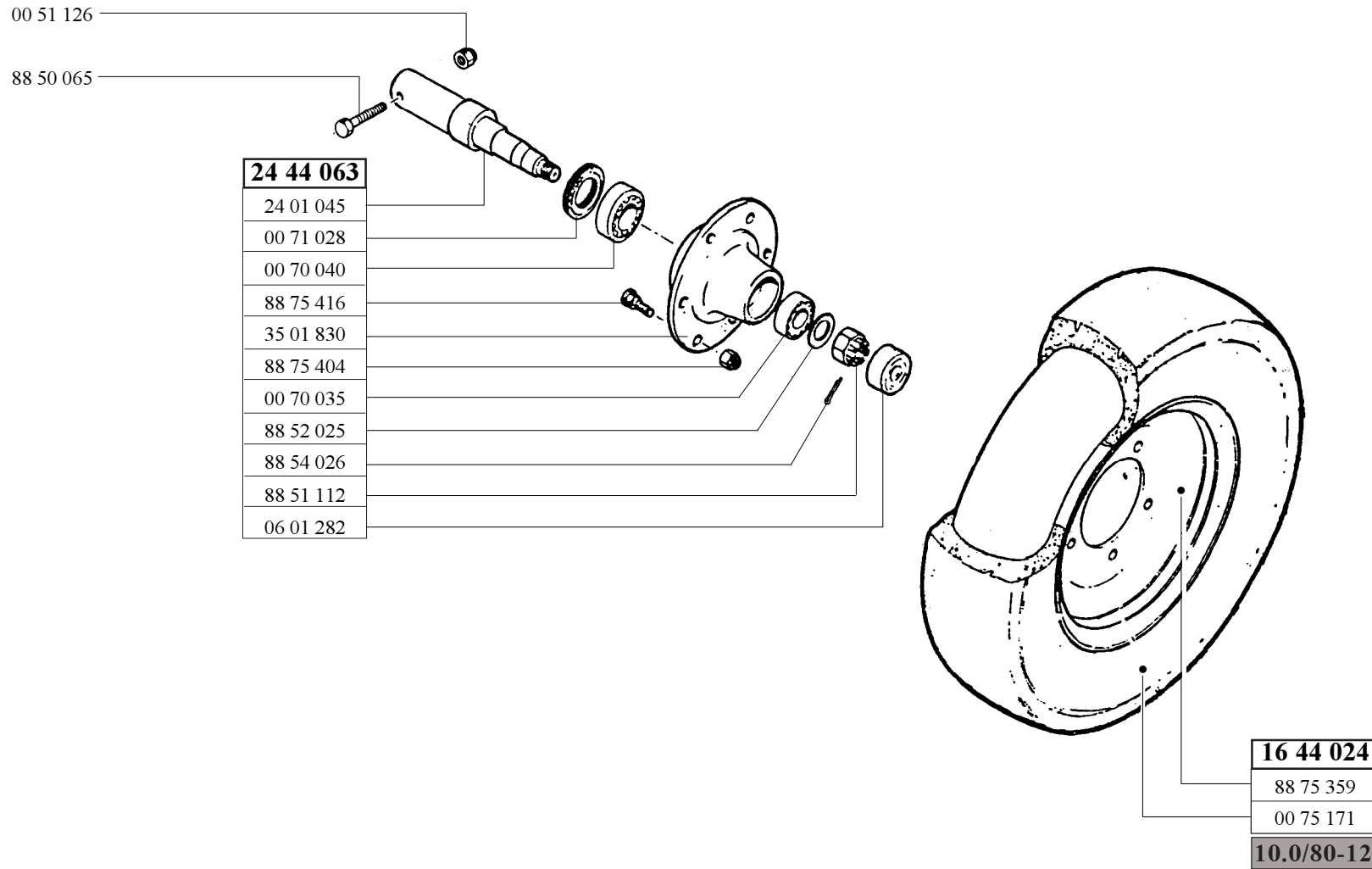

(**1** → 142280)

00 51 126

88 50 065

24 44 002
24 01 045
00 71 028
00 70 040
88 75 416
06 01 280
88 75 404
00 70 035
88 52 025
88 54 026
88 51 112
06 01 282

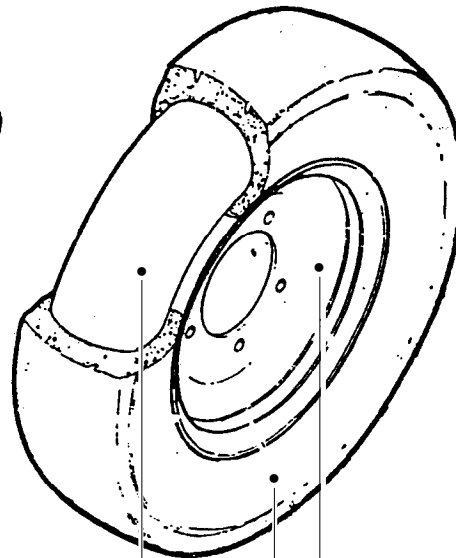
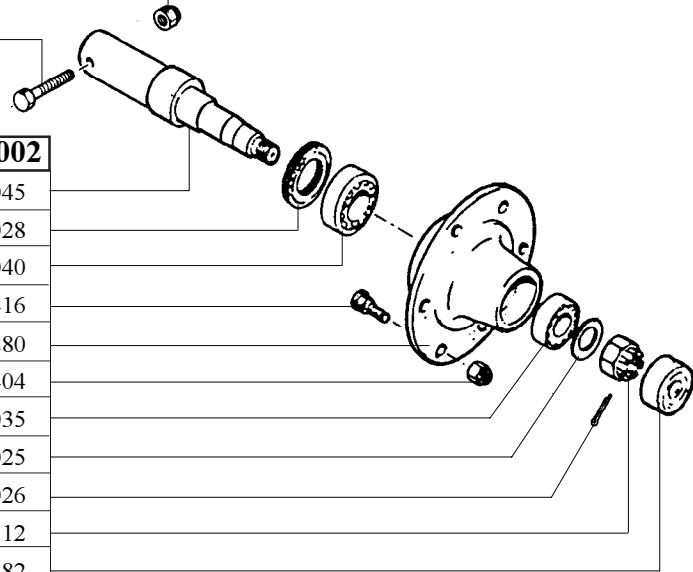



24 44 004
88 75 340
00 75 141
00 75 232
205/75-15



24 44 060
88 75 340
00 75 162
00 75 232
205/65-15

(→ 142279)

A	88 52 320 (sp 0,2)
	88 52 321 (sp 0,3)
	88 52 819 (sp 0,5)
B	88 52 362 (sp 1)
	88 52 814 (sp 0,2)
	88 52 815 (sp 0,3)
	88 52 816 (sp 0,5)
	88 52 817 (sp 1)
	88 52 378 (sp 5)

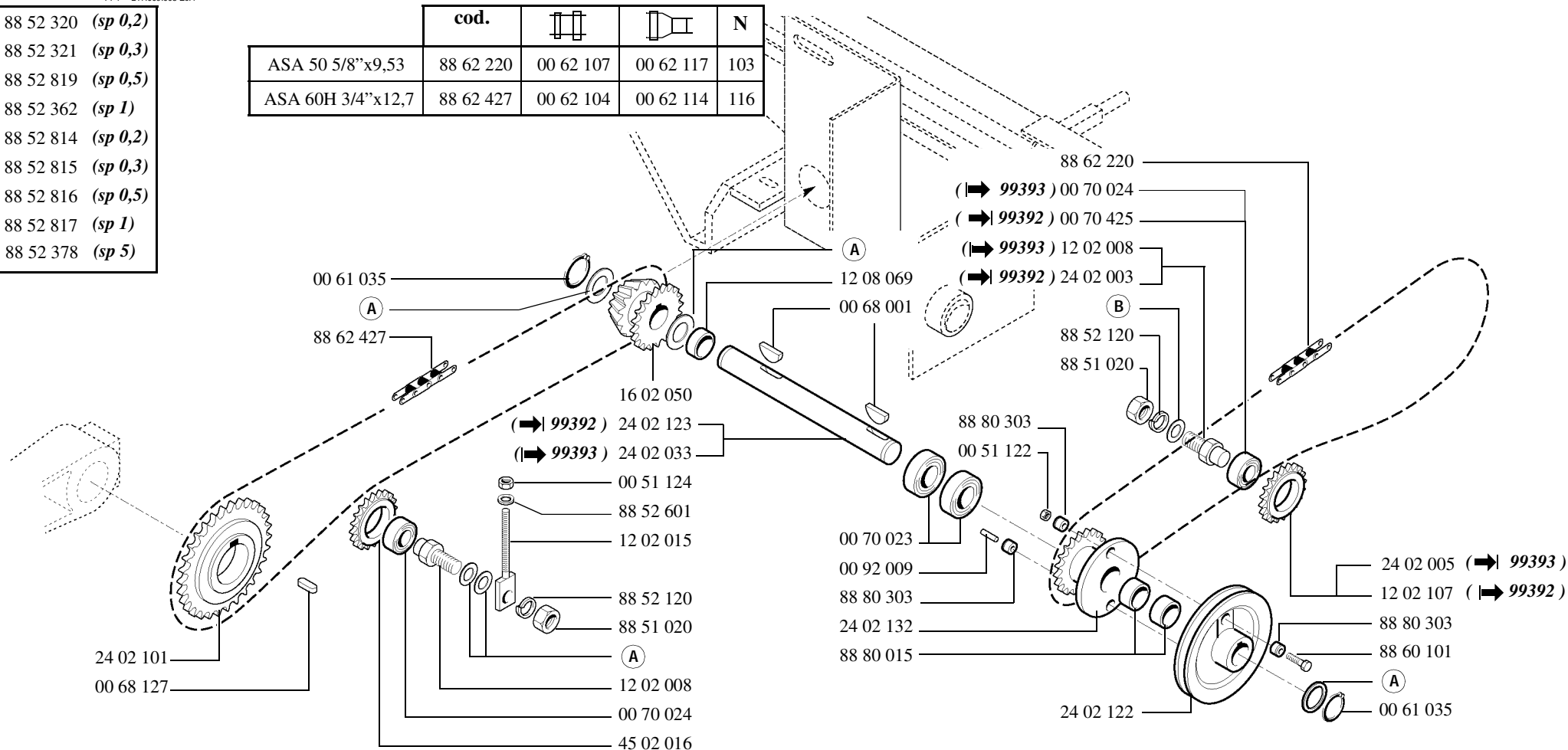
	cod.			N
ASA 50 5/8"x9,53	88 62 220	00 62 107	00 62 117	103
ASA 60H 3/4"x12,7	88 62 427	00 62 104	00 62 114	116



	cod.			N
ASA 60H 3/4"x12,7	88 62 430	00 62 104	00 62 114	66

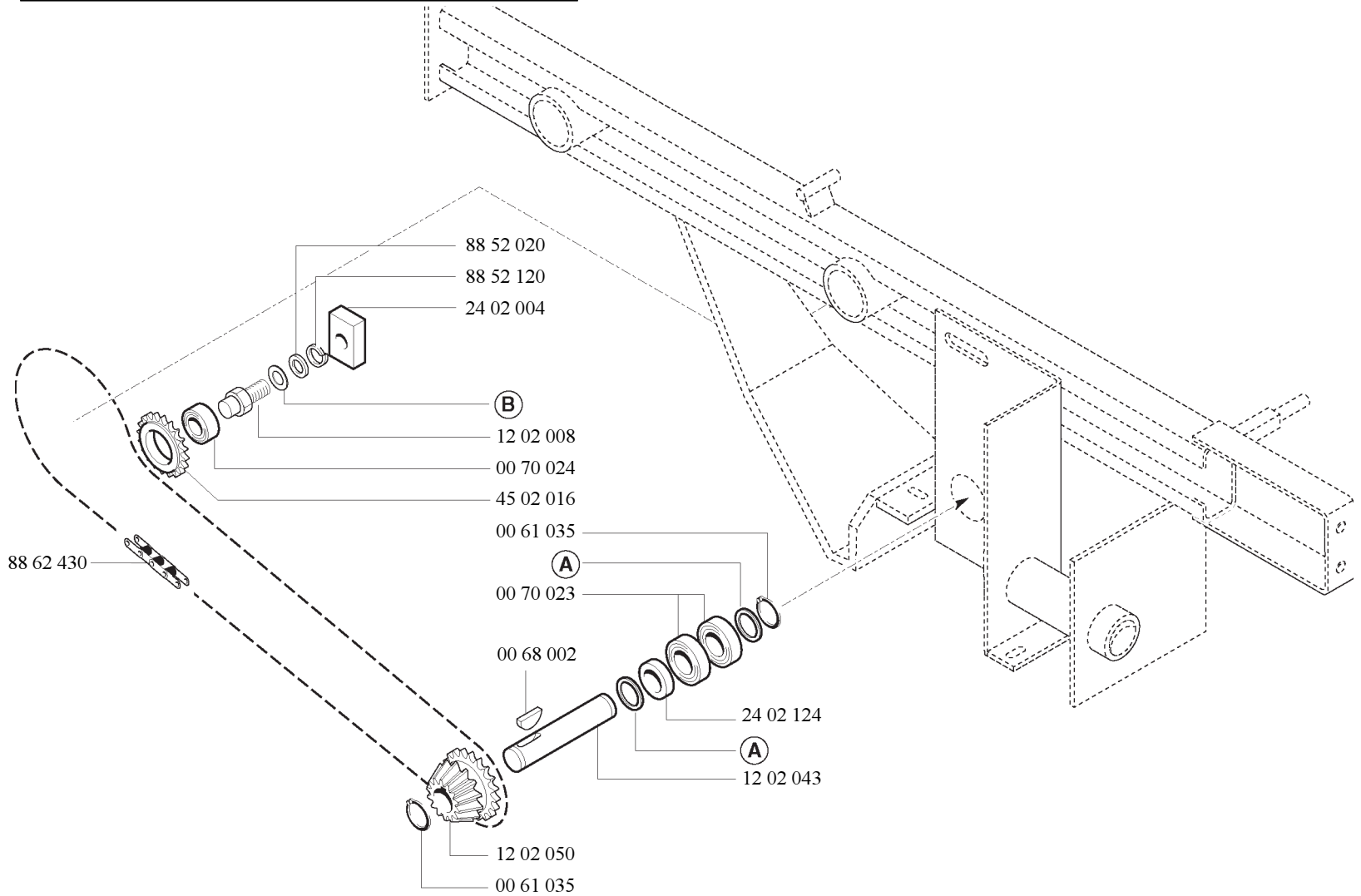

- (A) { 88 52 320 (sp 0,2)
- 88 52 321 (sp 0,3)
- 88 52 819 (sp 0,5)
- 88 52 362 (sp 1)
- (B) { 88 52 814 (sp 0,2)
- 88 52 815 (sp 0,3)
- 88 52 816 (sp 0,5)
- 88 52 817 (sp 1)

- | | |
|---|--------------------|
| A | 88 52 372 (sp 0,2) |
| | 88 52 373 (sp 0,3) |
| | 88 52 374 (sp 0,5) |
| | 88 52 205 (sp 1) |

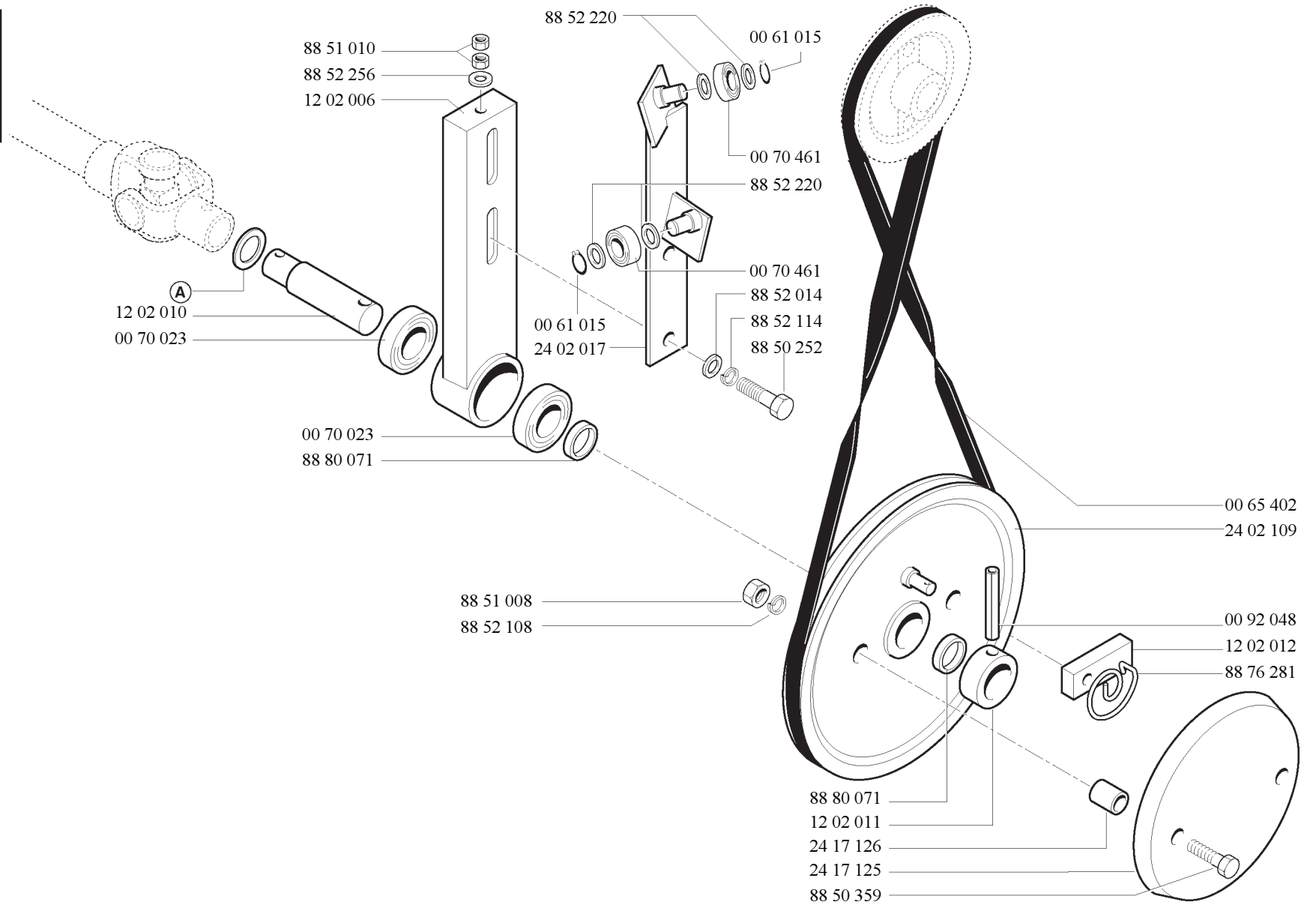

- | | |
|----------|--------------------|
| A | 24 03 083 (sp 0,3) |
| | 24 03 082 (sp 0,5) |
| | 24 03 081 (sp 1) |

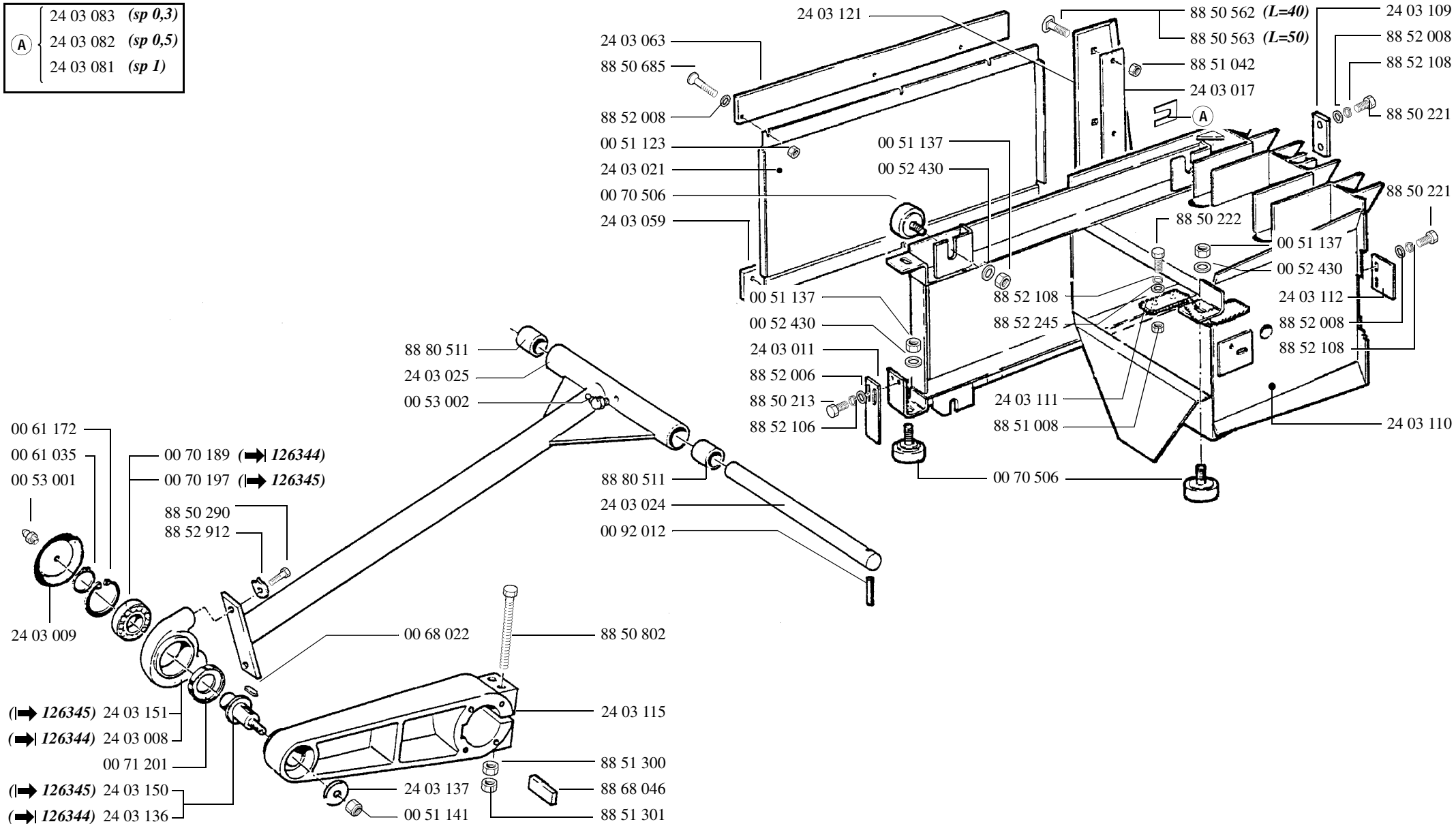

- | | |
|---|--------------------|
| A | 06 03 075 (sp 0,3) |
| | 06 03 076 (sp 0,5) |
| | 06 03 077 (sp 1) |
| | 06 03 078 (sp 1,5) |
| B | 24 03 155 (sp 0,3) |
| | 24 03 156 (sp 0,5) |
| | 24 03 157 (sp 1) |
| | 24 03 158 (sp 1,5) |
| C | 24 03 075 (sp 0,3) |
| | 24 03 076 (sp 0,5) |
| | 24 03 077 (sp 1,5) |

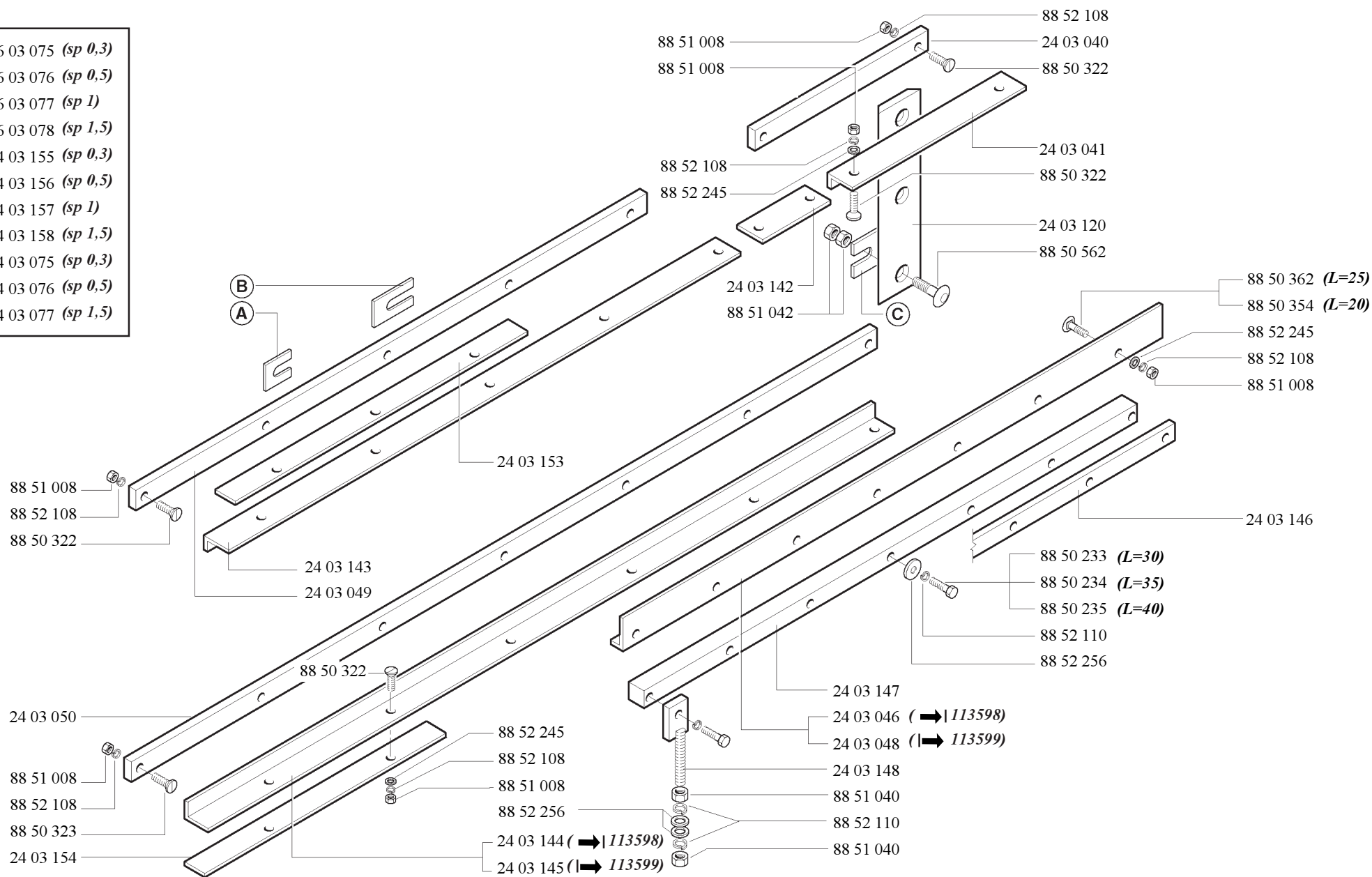

24 44 027

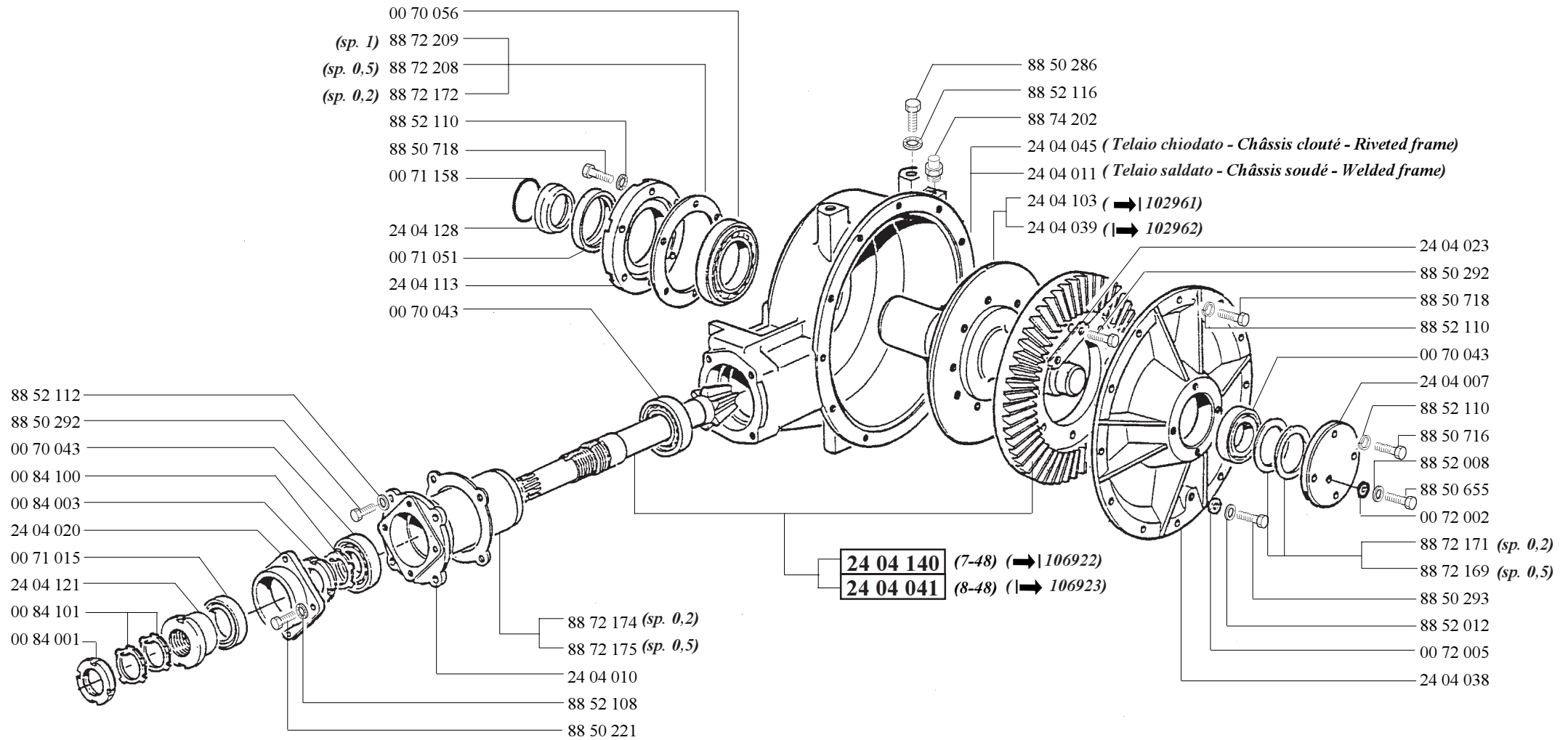

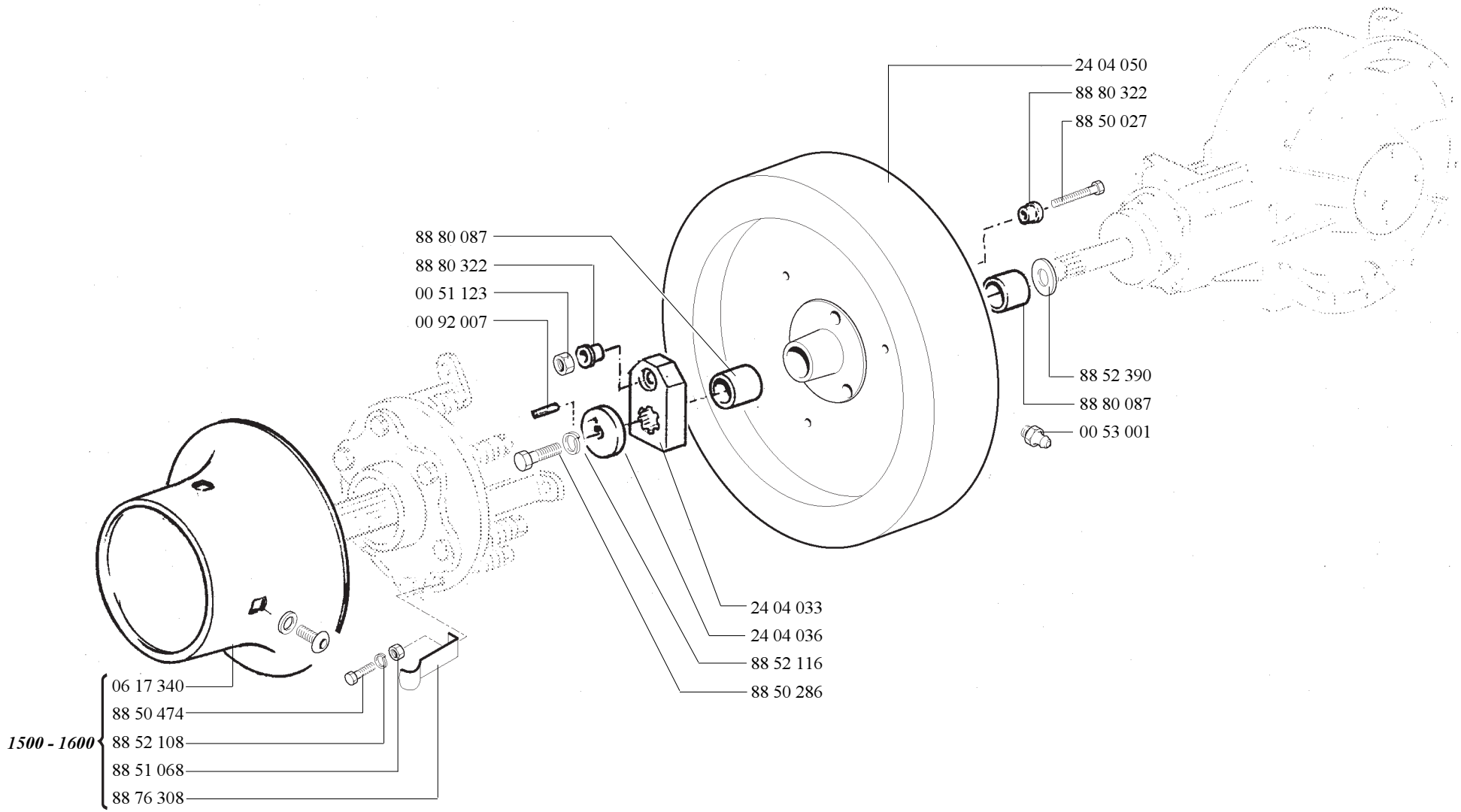

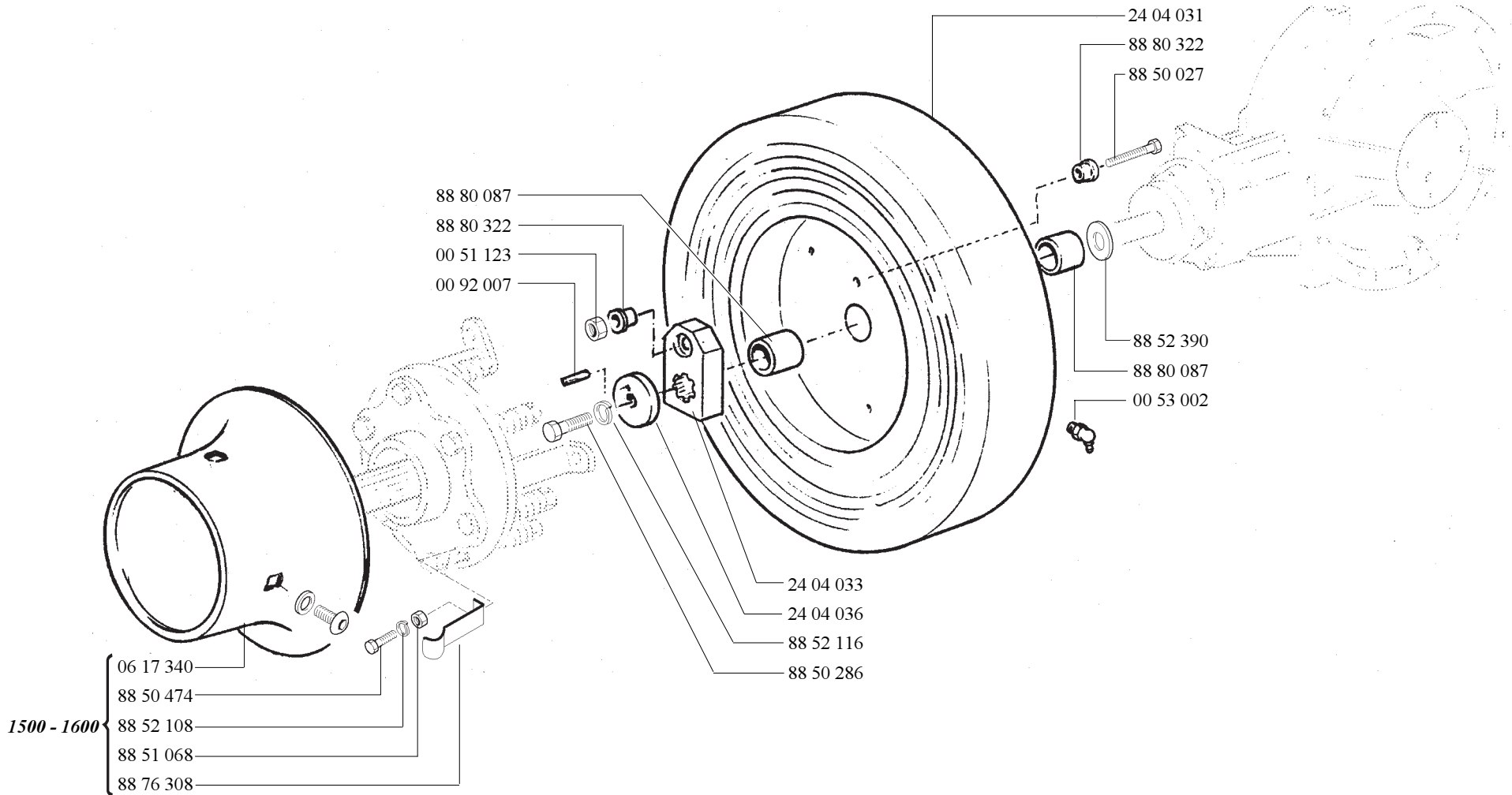

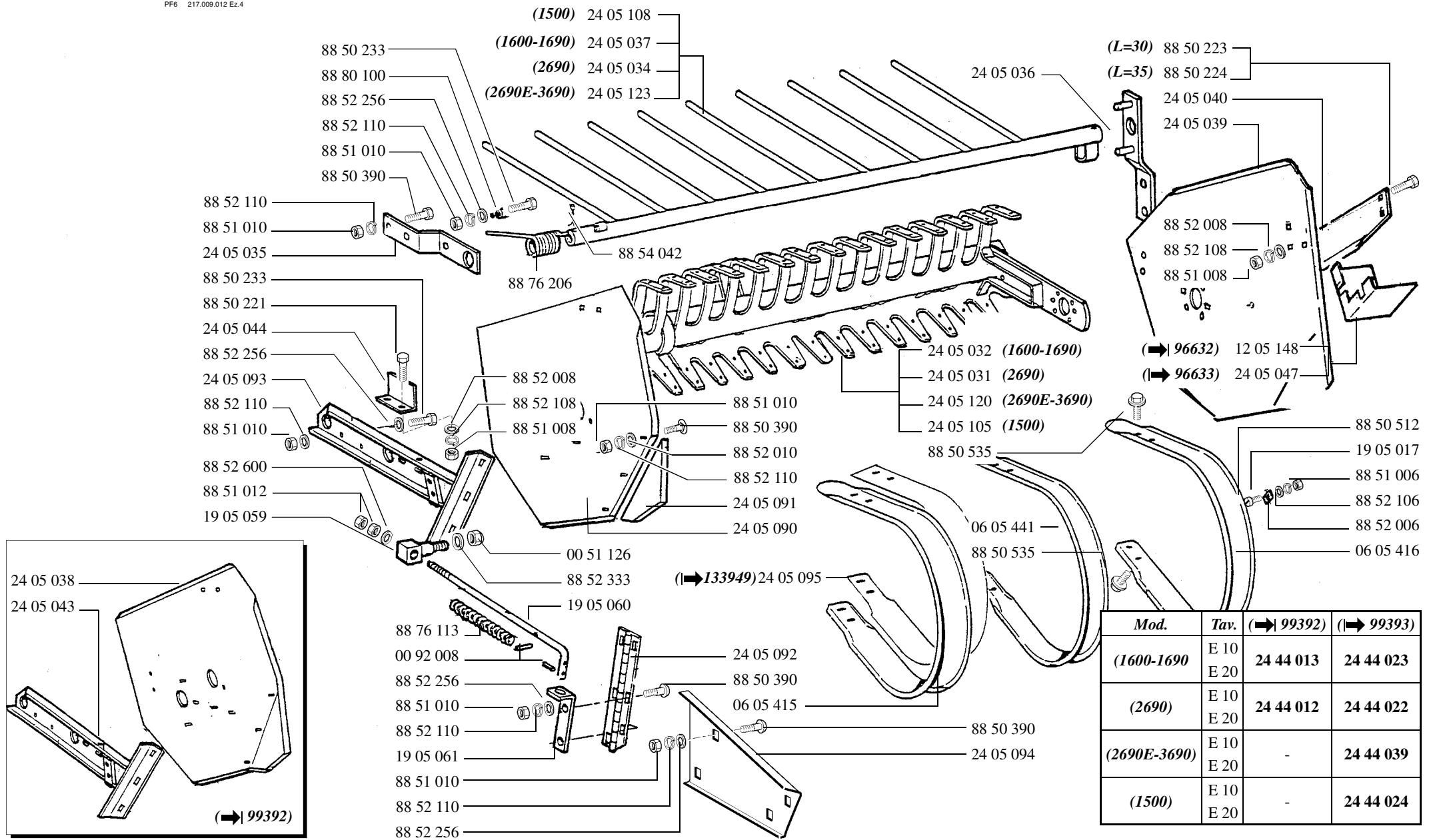

Mod.	Tav.	(→ 99392)	(→ 99393)
(1600-1690)	E 10	24 44 013	24 44 023
	E 20		
(2690)	E 10	24 44 012	24 44 022
	E 20		
(2690E-3690)	E 10	-	24 44 039
	E 20		
(1500)	E 10	-	24 44 024
	E 20		

A 88 52 205 (sp 1)
88 52 374 (sp 0,5)

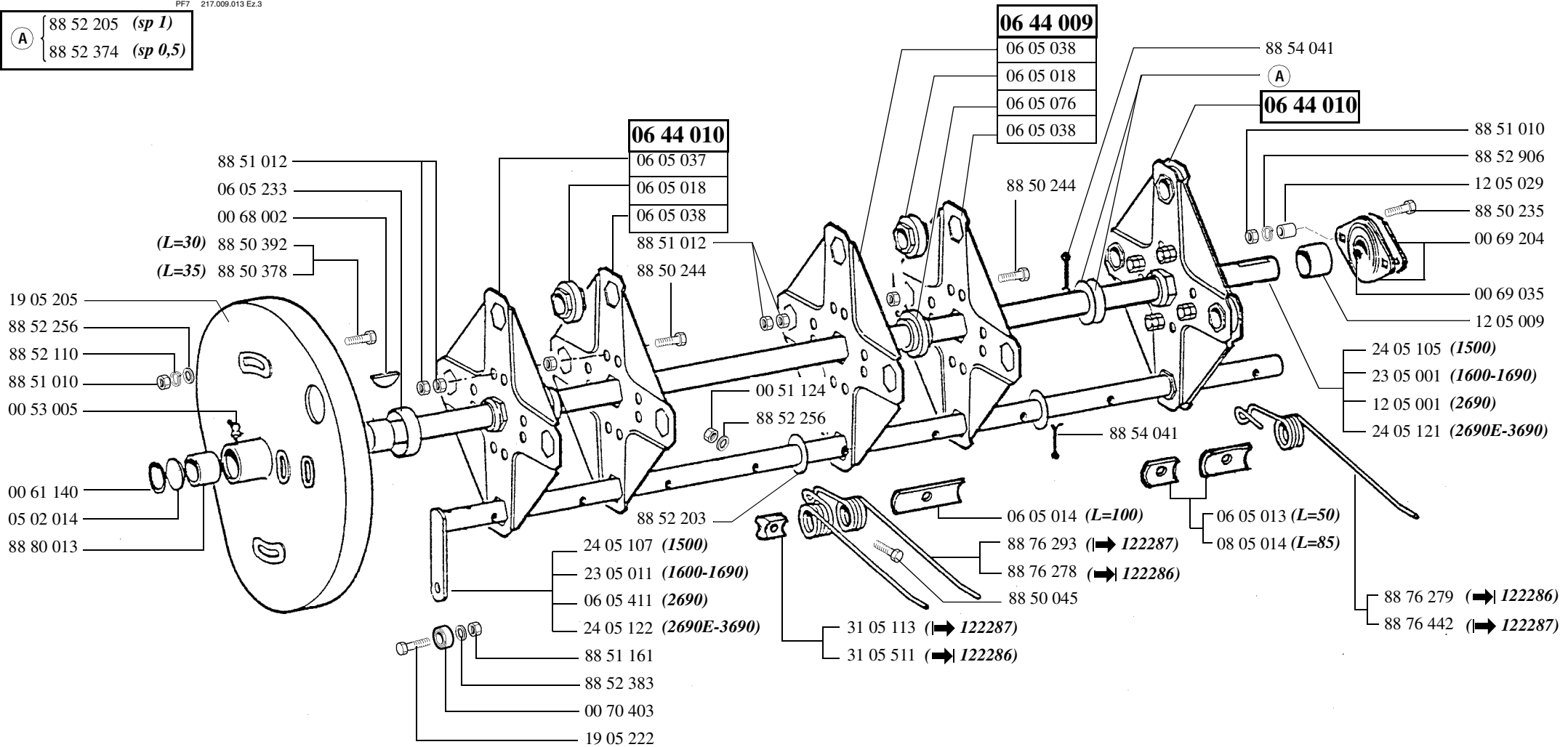

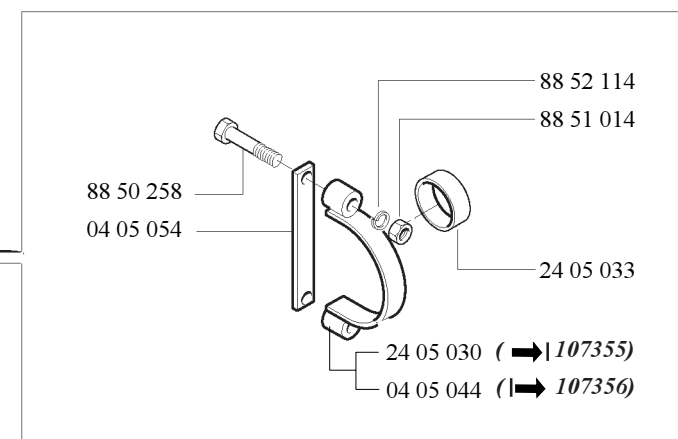
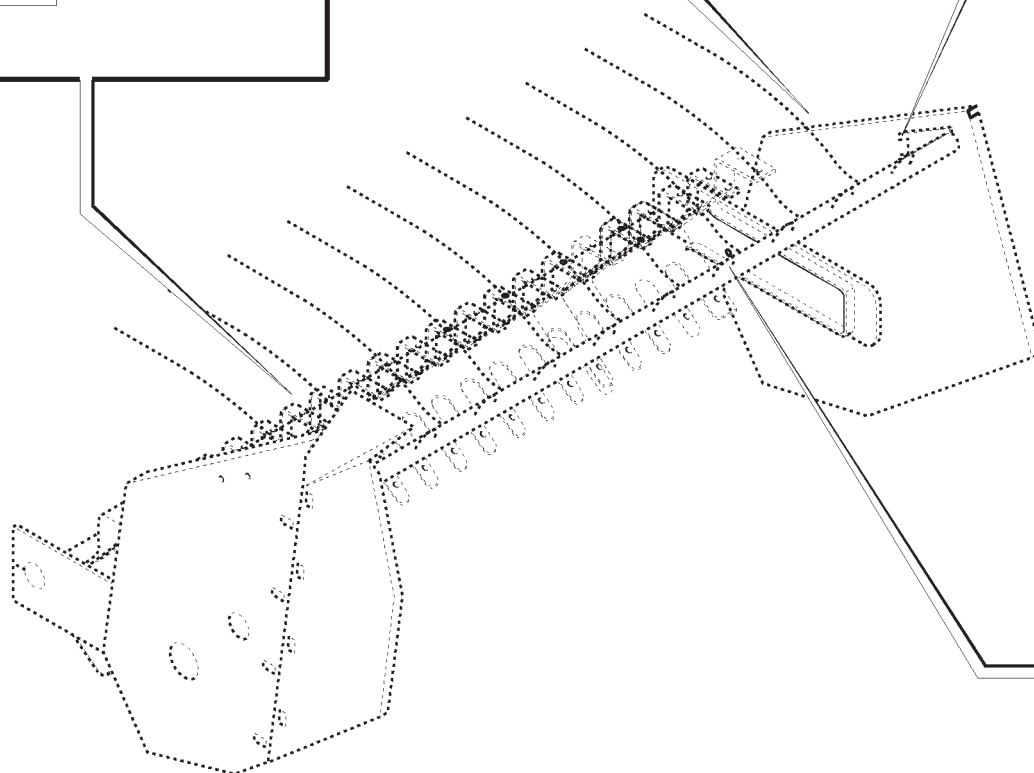
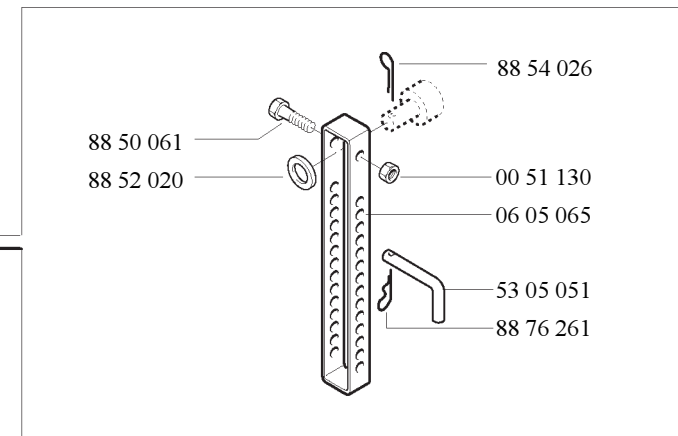
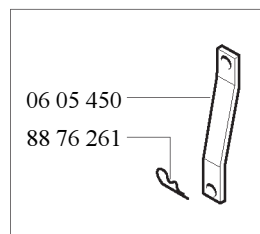
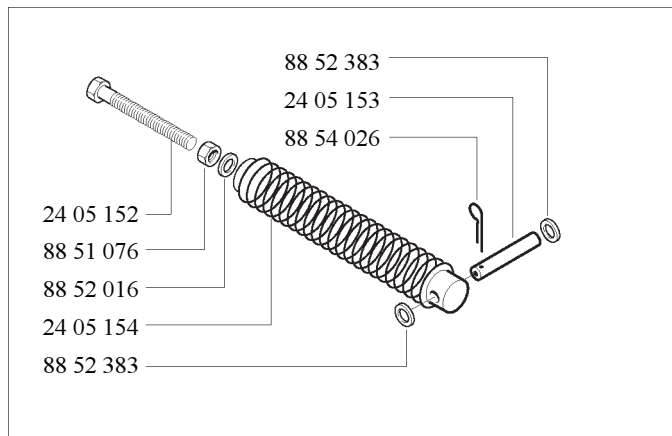

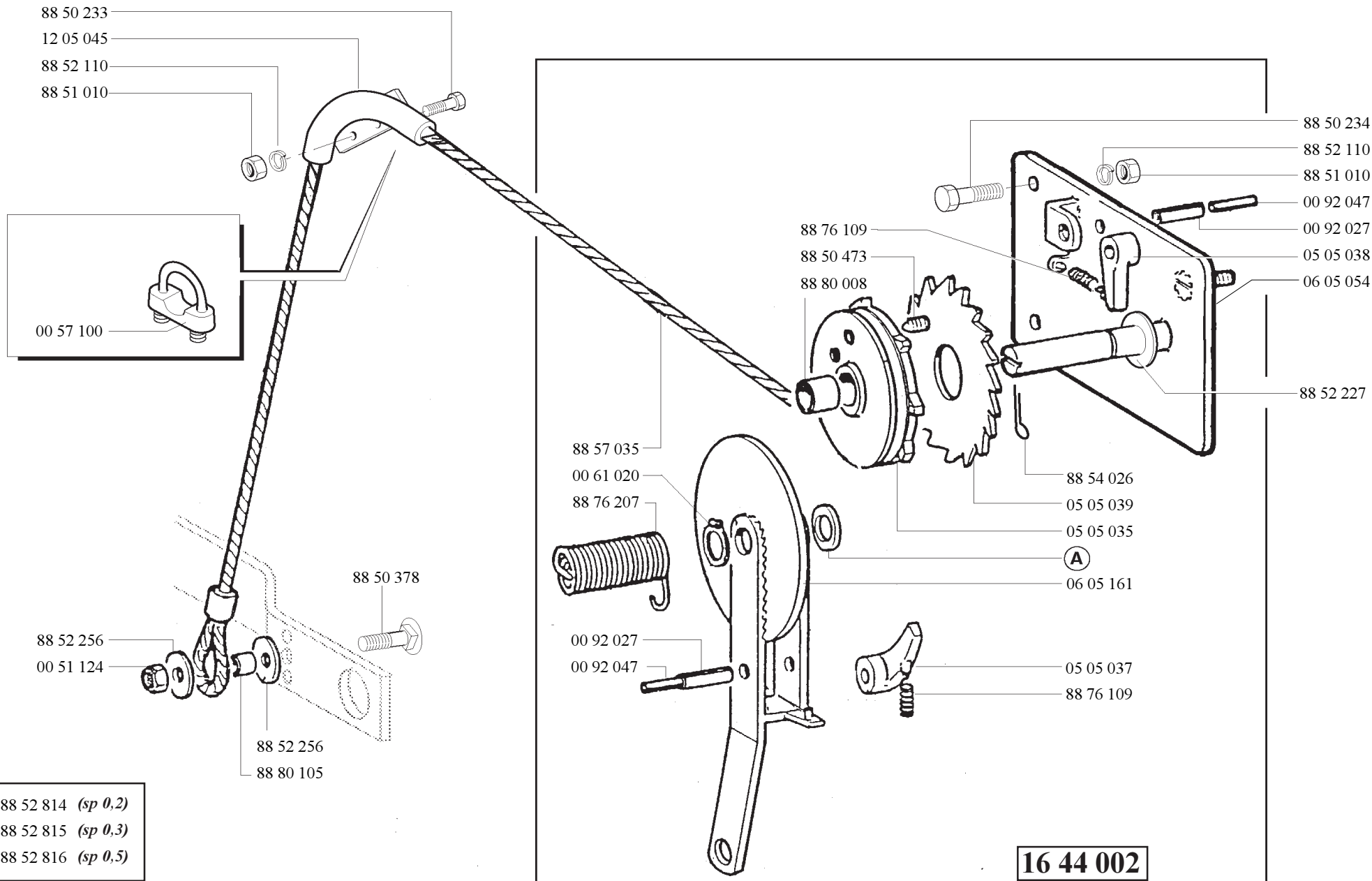

- | | |
|-----|--------------------|
| (A) | 88 52 814 (sp 0,2) |
| | 88 52 815 (sp 0,3) |
| | 88 52 816 (sp 0,5) |

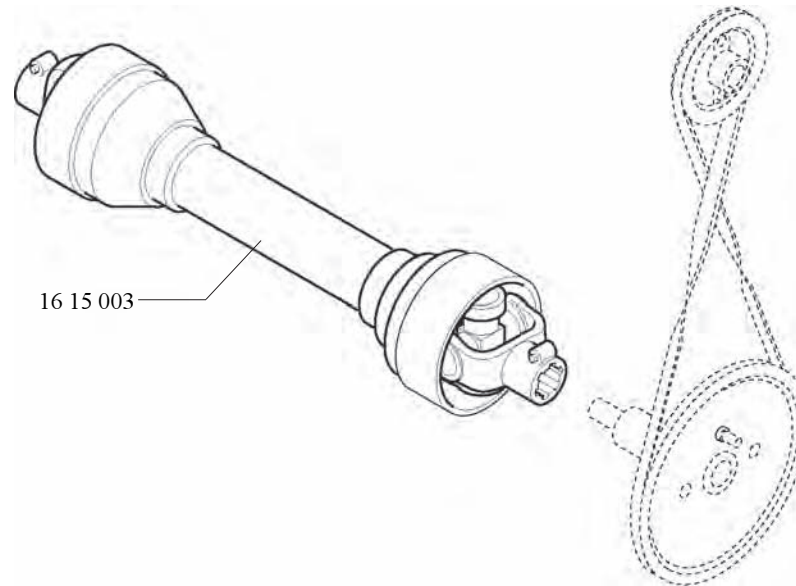

(**1** → **126345**)

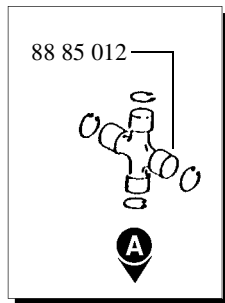
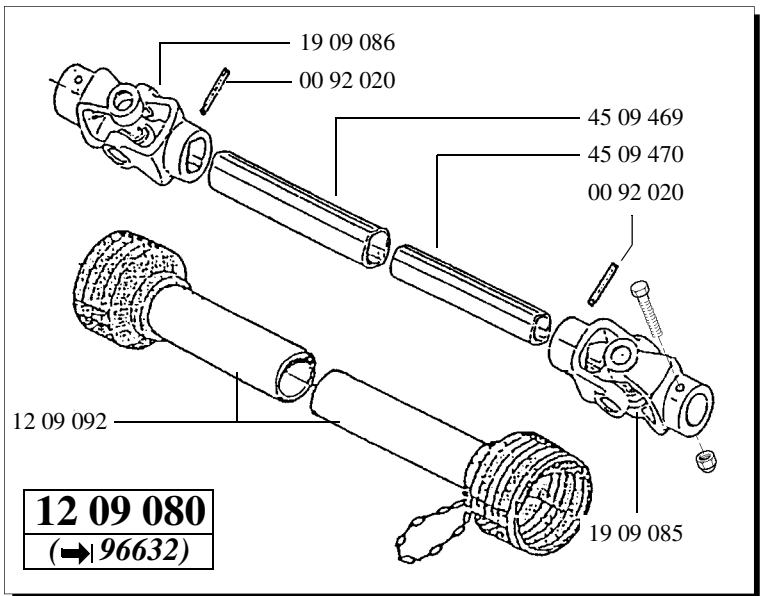
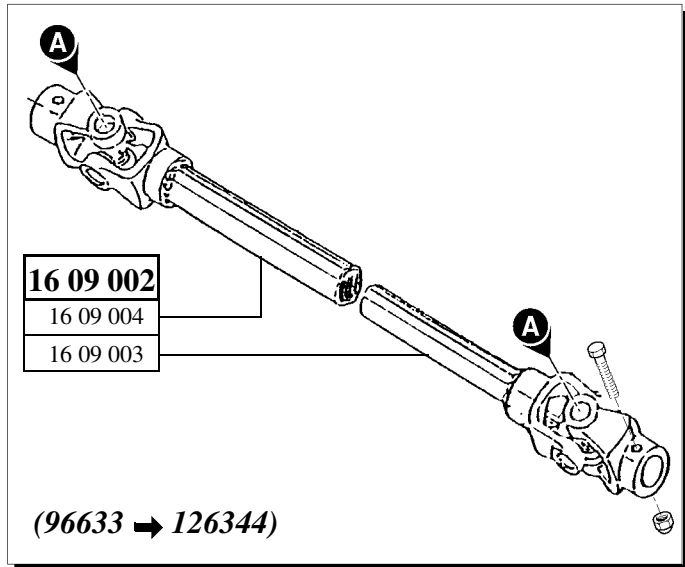
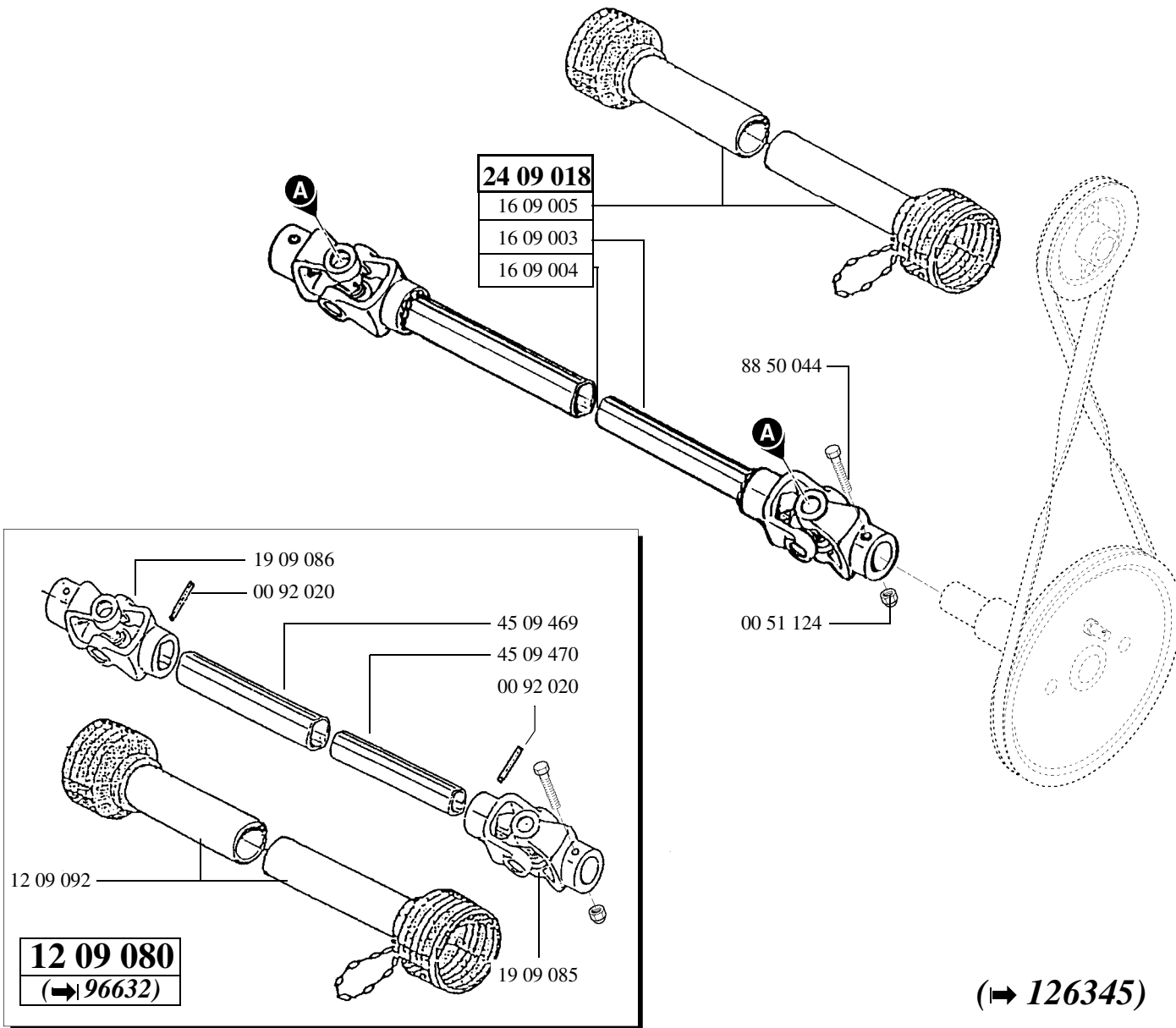

(→ 126345)

- (A)** { 88 52 218 (sp 0,5)
88 52 219 (sp 0,8)
88 52 220 (sp 1,5)
88 52 221 (sp 2)
- (B)** { 88 52 814 (sp 0,2)
88 52 816 (sp 0,5)
88 52 817 (sp 1)
- (C)** { 88 52 205 (sp 1)
88 52 206 (sp 1,2)
88 52 207 (sp 1,5)
88 52 208 (sp 2)
88 52 372 (sp 0,2)
88 52 374 (sp 0,5)

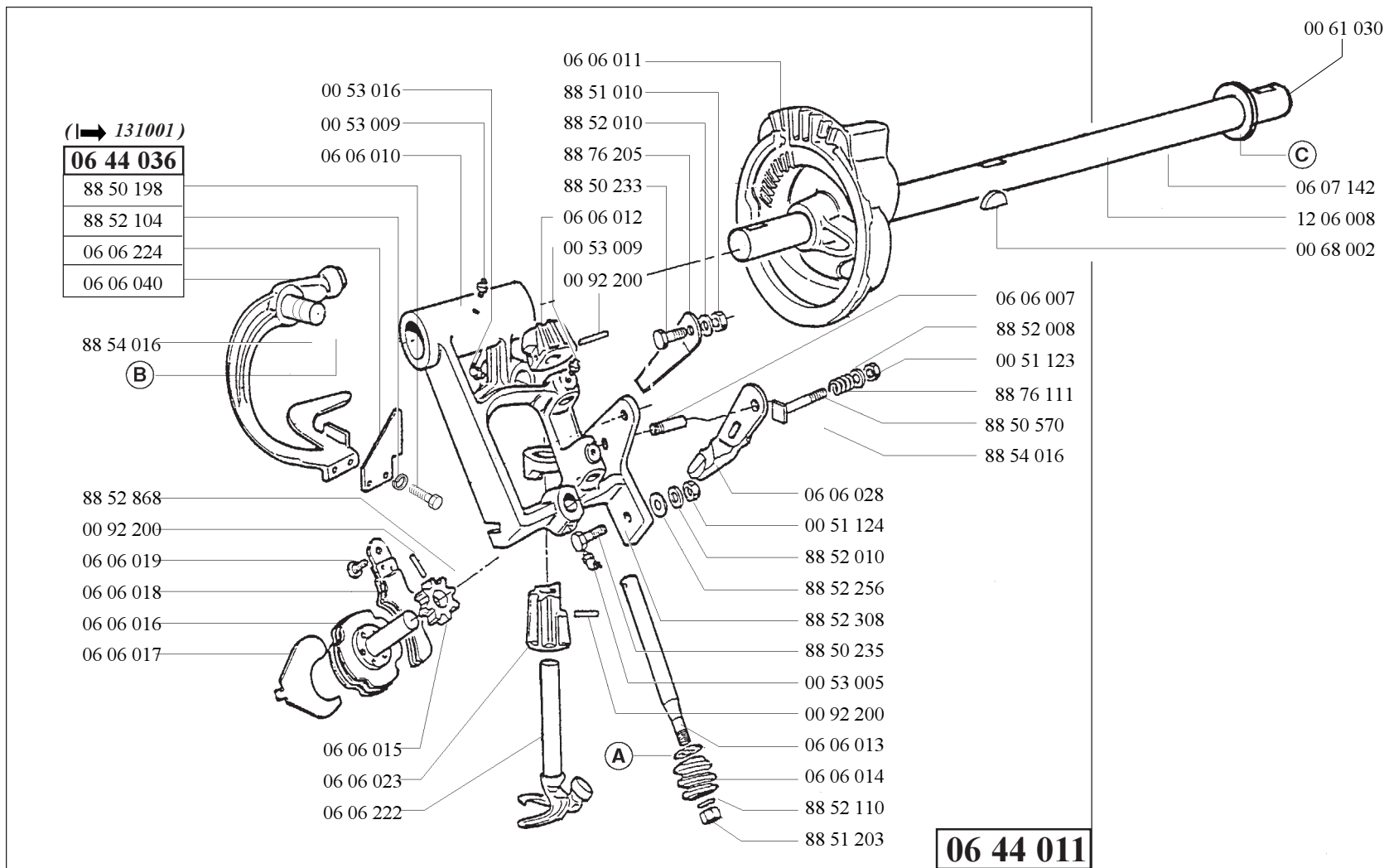

(I → 99393)

- (A)** { 88 52 218 (sp 0,5)
- 88 52 219 (sp 0,8)
- 88 52 220 (sp 1,5)
- 88 52 221 (sp 2)
- (B)** { 88 52 814 (sp 0,2)
- 88 52 816 (sp 0,5)
- 88 52 817 (sp 1)
- (C)** { 88 52 205 (sp 1)
- 88 52 206 (sp 1,2)
- 88 52 207 (sp 1,5)
- 88 52 208 (sp 2)
- 88 52 372 (sp 0,2)
- 88 52 374 (sp 0,5)

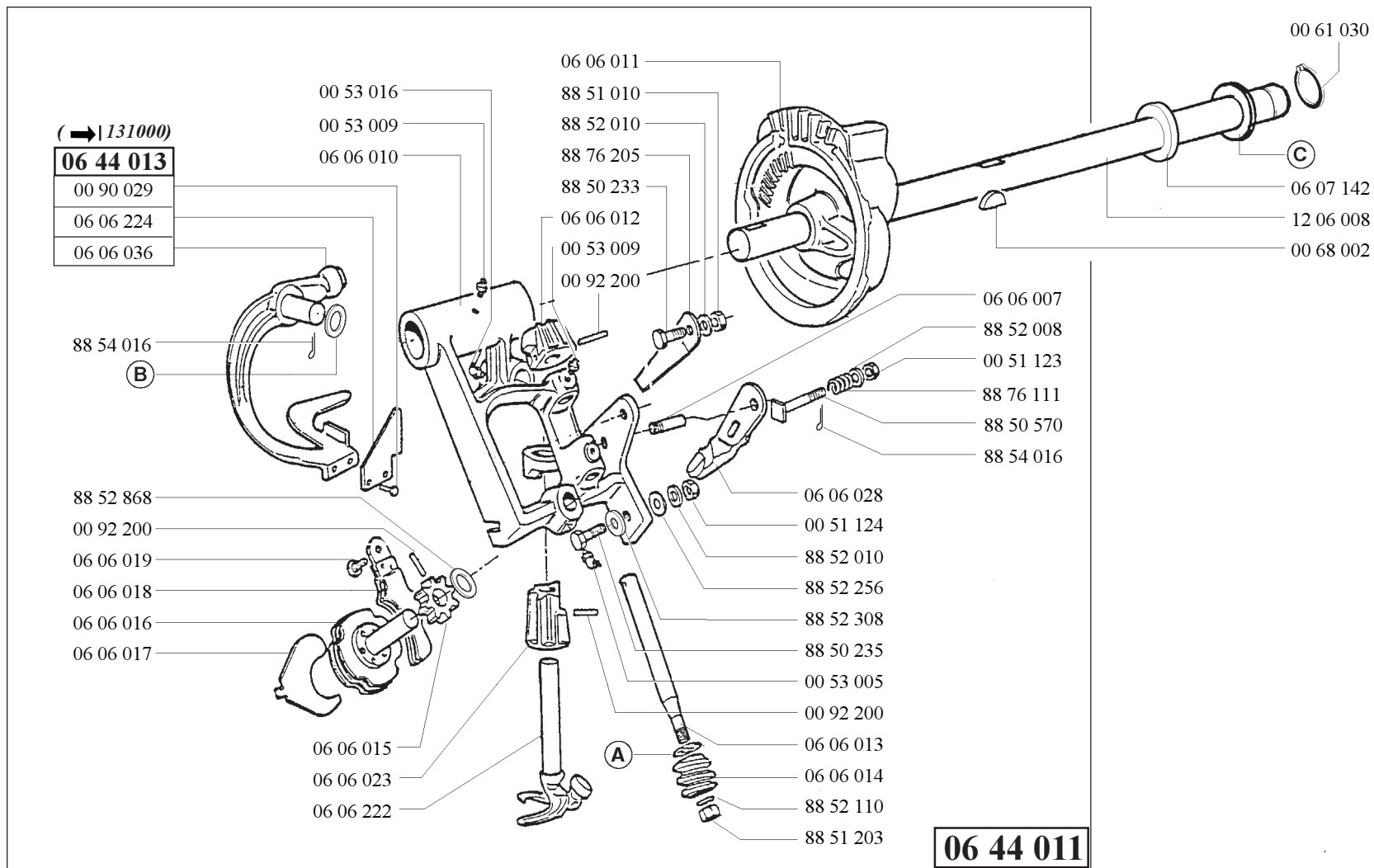

(→ 99393)

- (A) { 88 52 218 (sp 0,5)
- 88 52 219 (sp 0,8)
- 88 52 220 (sp 1,5)
- 88 52 221 (sp 2)
- (B) { 88 52 814 (sp 0,2)
- 88 52 816 (sp 0,5)
- 88 52 817 (sp 1)
- (C) { 88 52 205 (sp 1)
- 88 52 206 (sp 1,2)
- 88 52 207 (sp 1,5)
- 88 52 208 (sp 2)
- 88 52 372 (sp 0,2)
- 88 52 374 (sp 0,5)

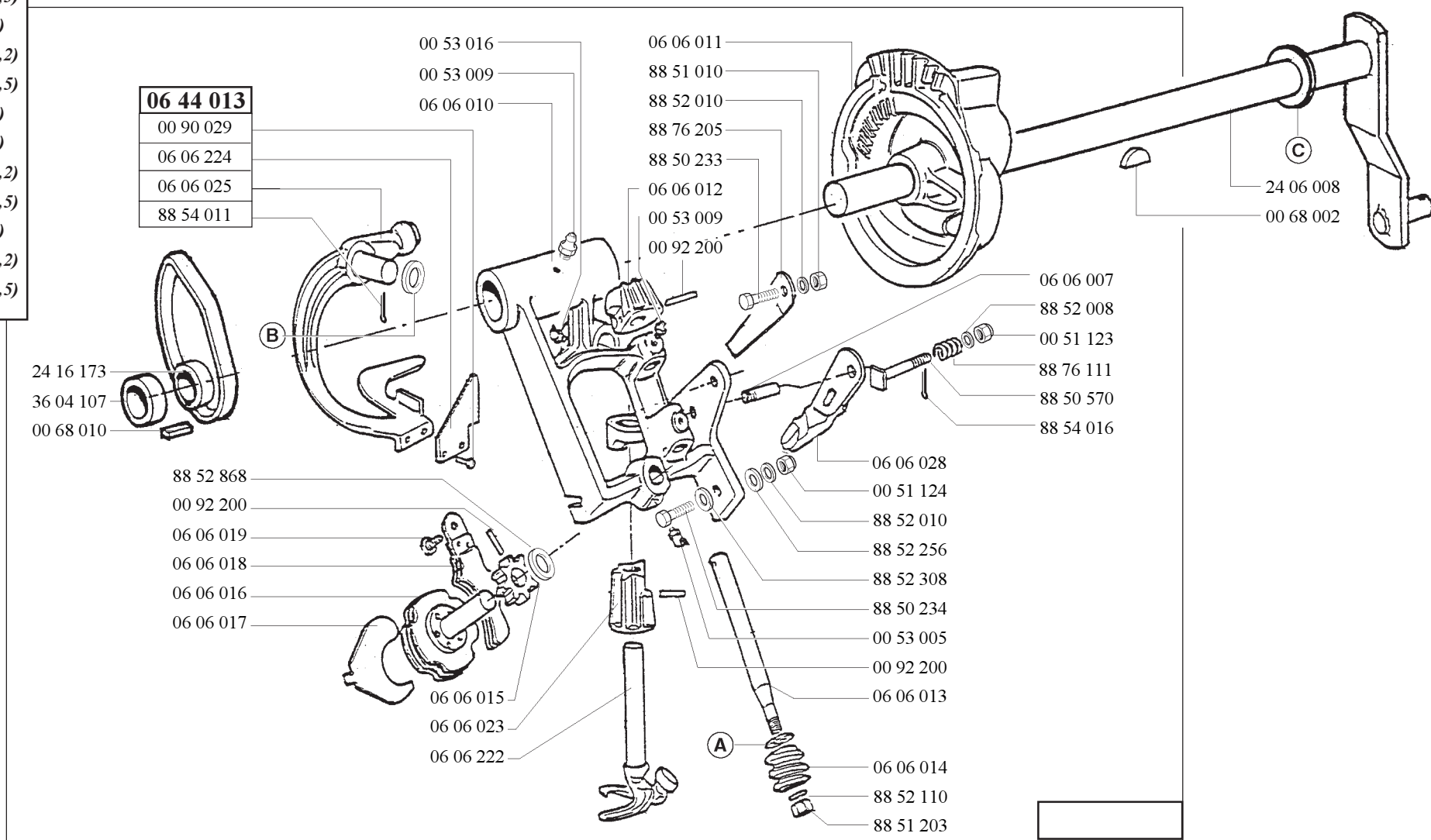

(→ 99392)

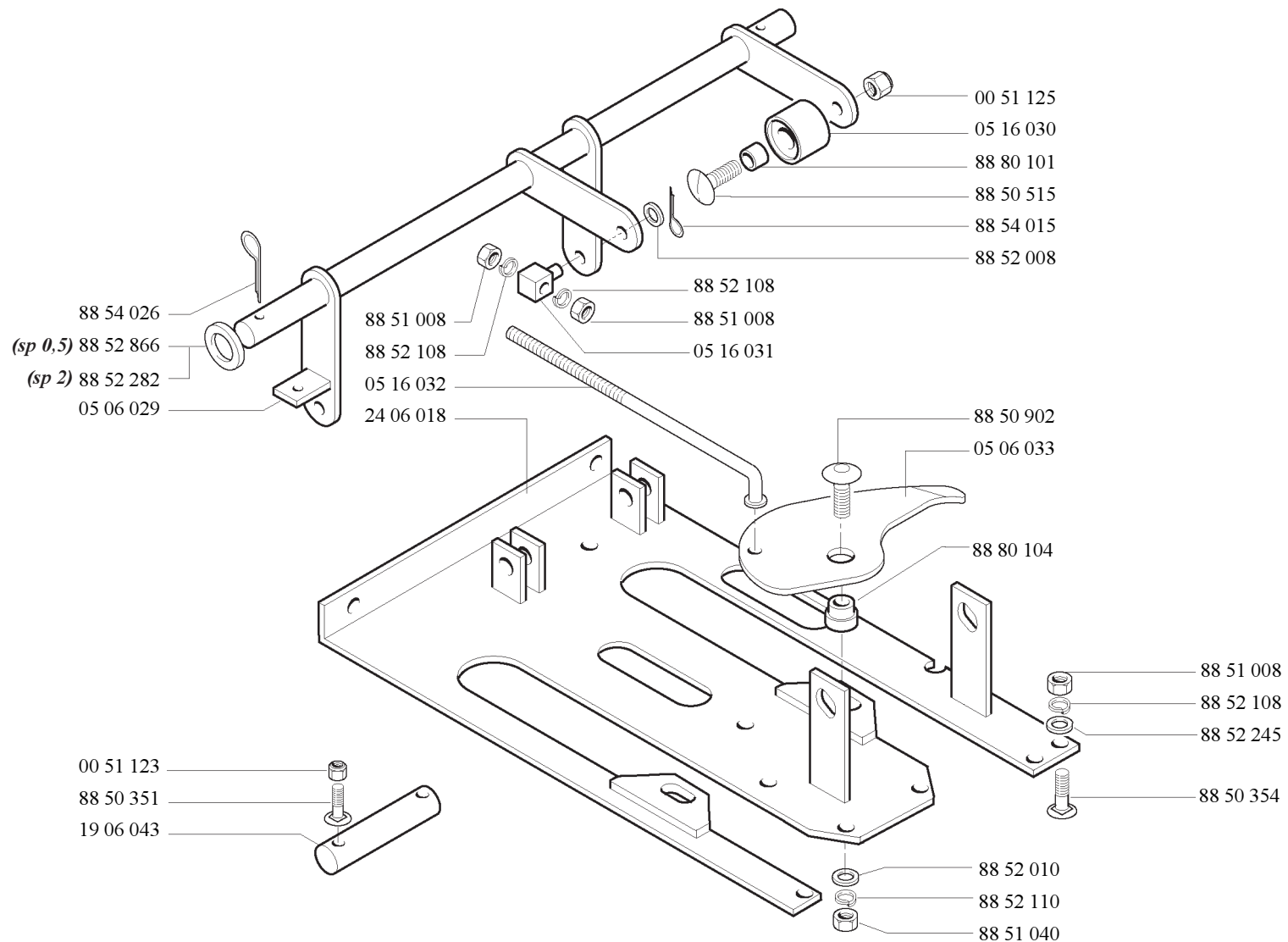

(I → 99393)

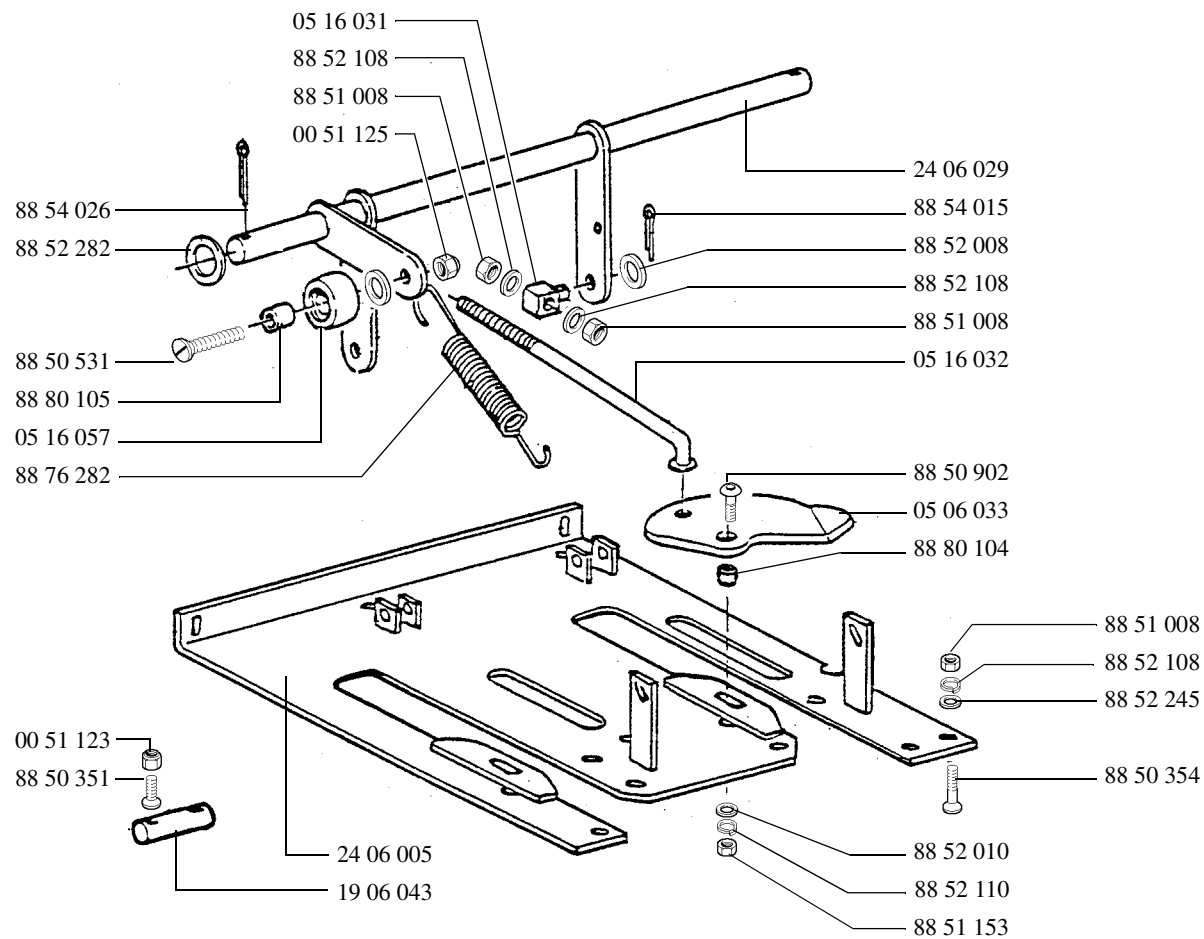

(→ 99392)

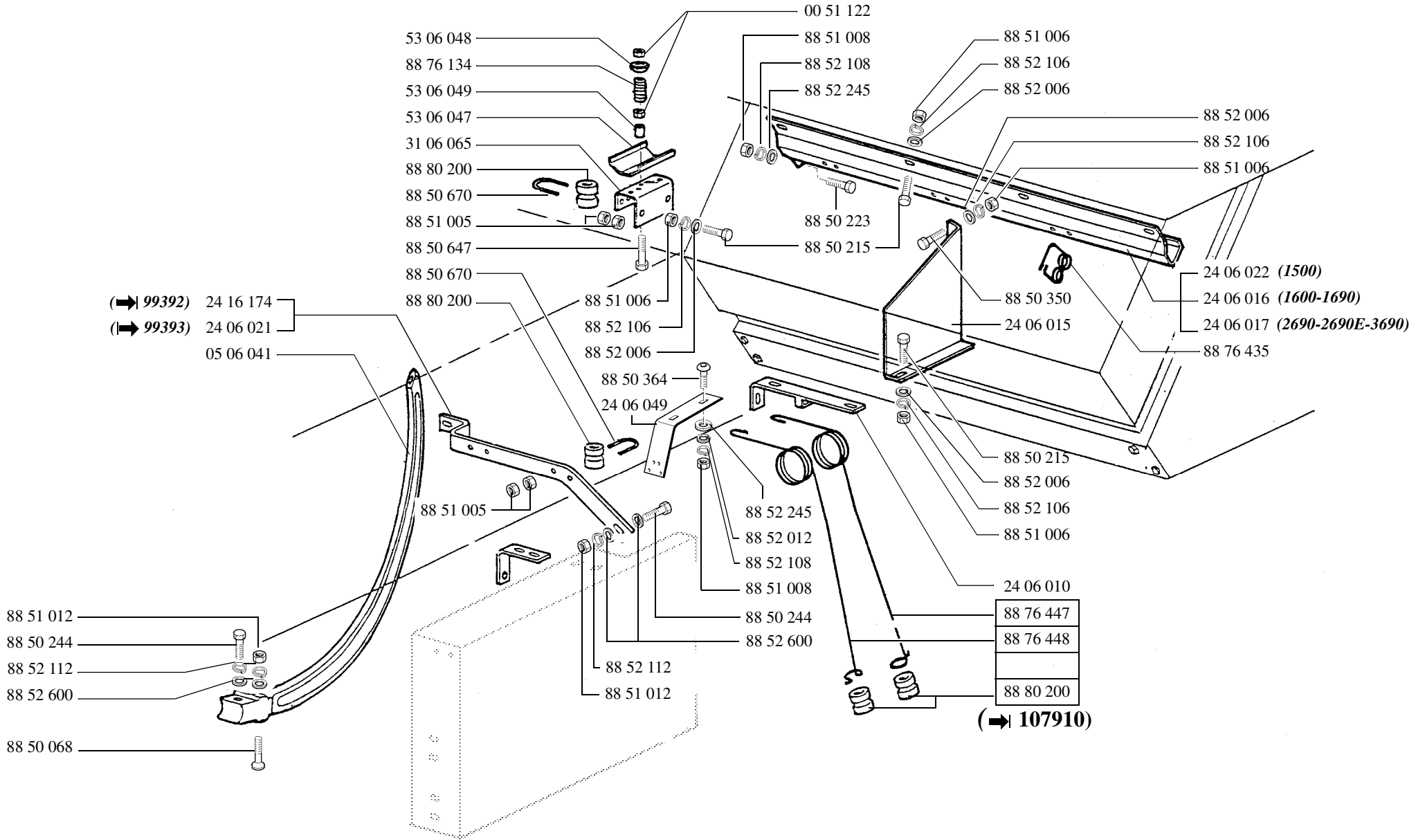

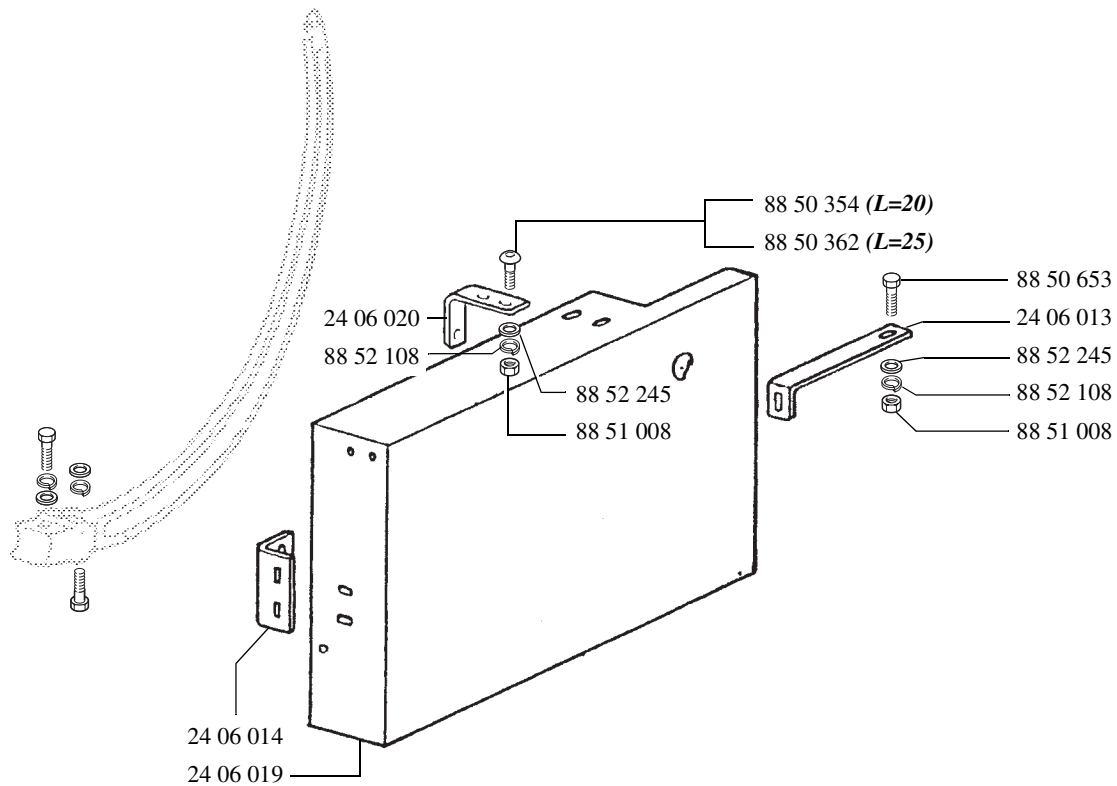

(**→ 99393**) 1690-2690-2690E-3690

(**→ 102968**) 1500-1600

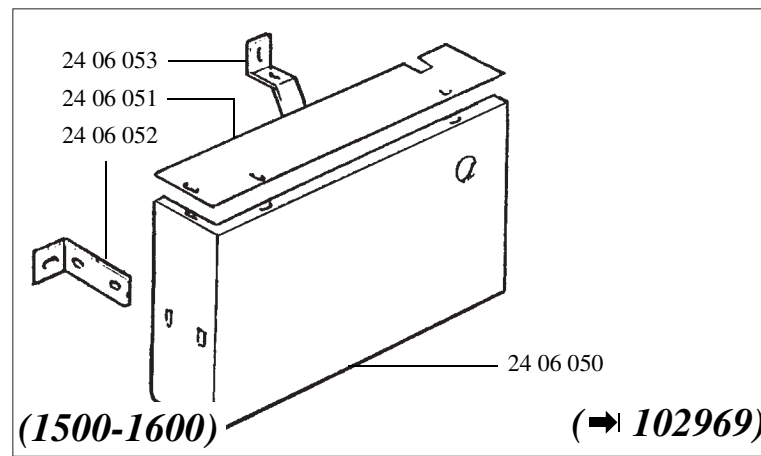
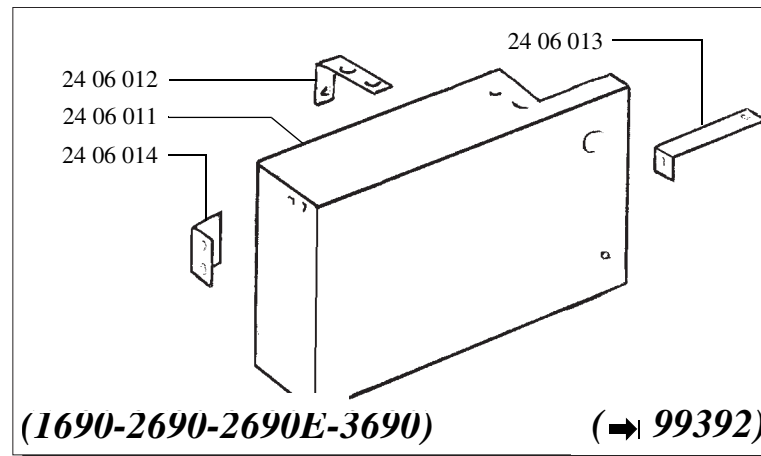

- (A)** { 88 52 865 (sp 0,3)
88 52 866 (sp 0,5)
88 52 360 (sp 1)
88 52 281 (sp 1,5)
- (B)** { 88 52 372 (sp 0,2)
88 52 374 (sp 0,5)
88 52 205 (sp 1)
- (C)** { 88 52 859 (sp 0,5)
88 52 310 (sp 1)
88 52 311 (sp 1,5)
88 52 312 (sp 2)
88 52 313 (sp 3)

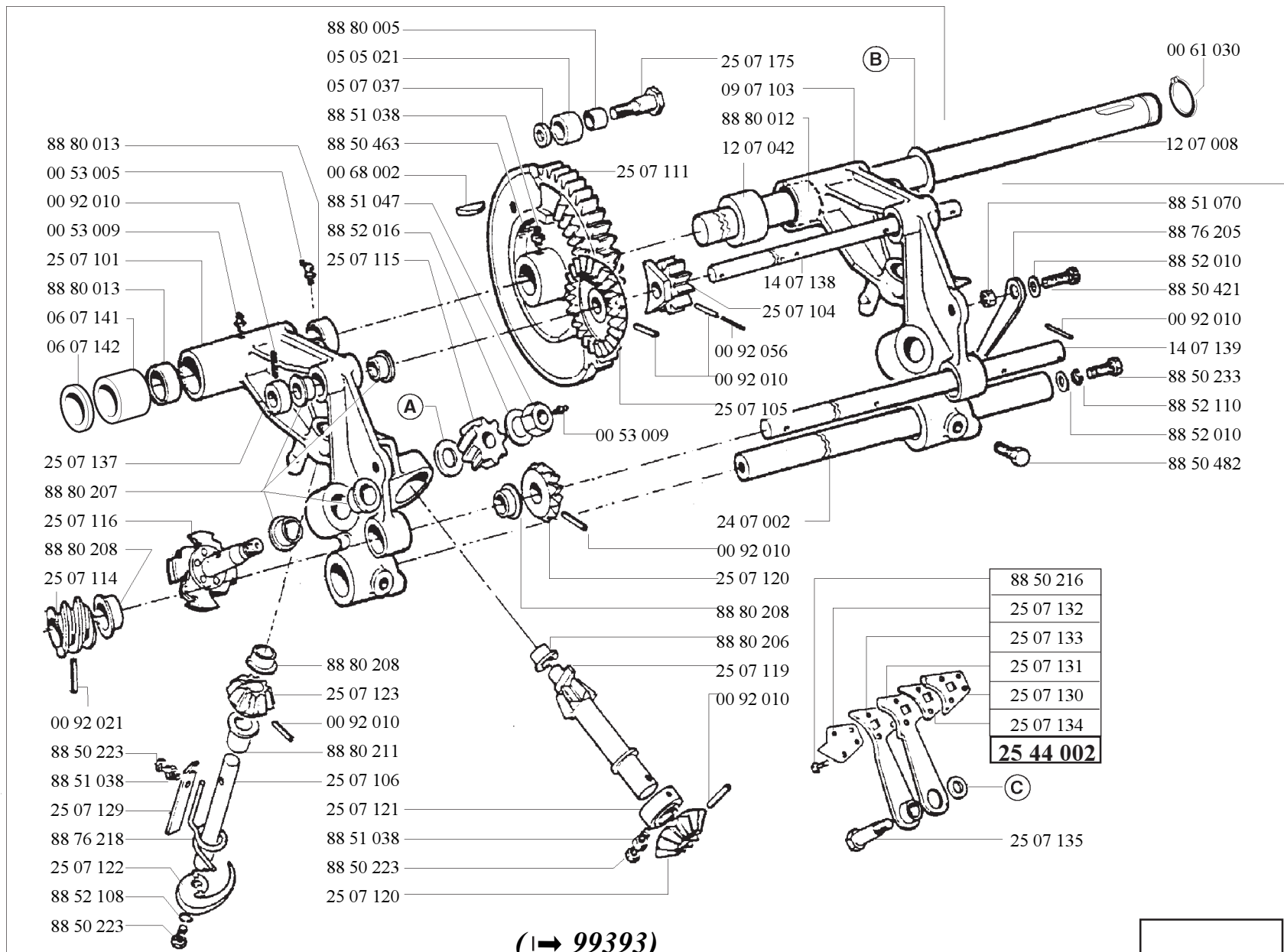

(I → 99393)

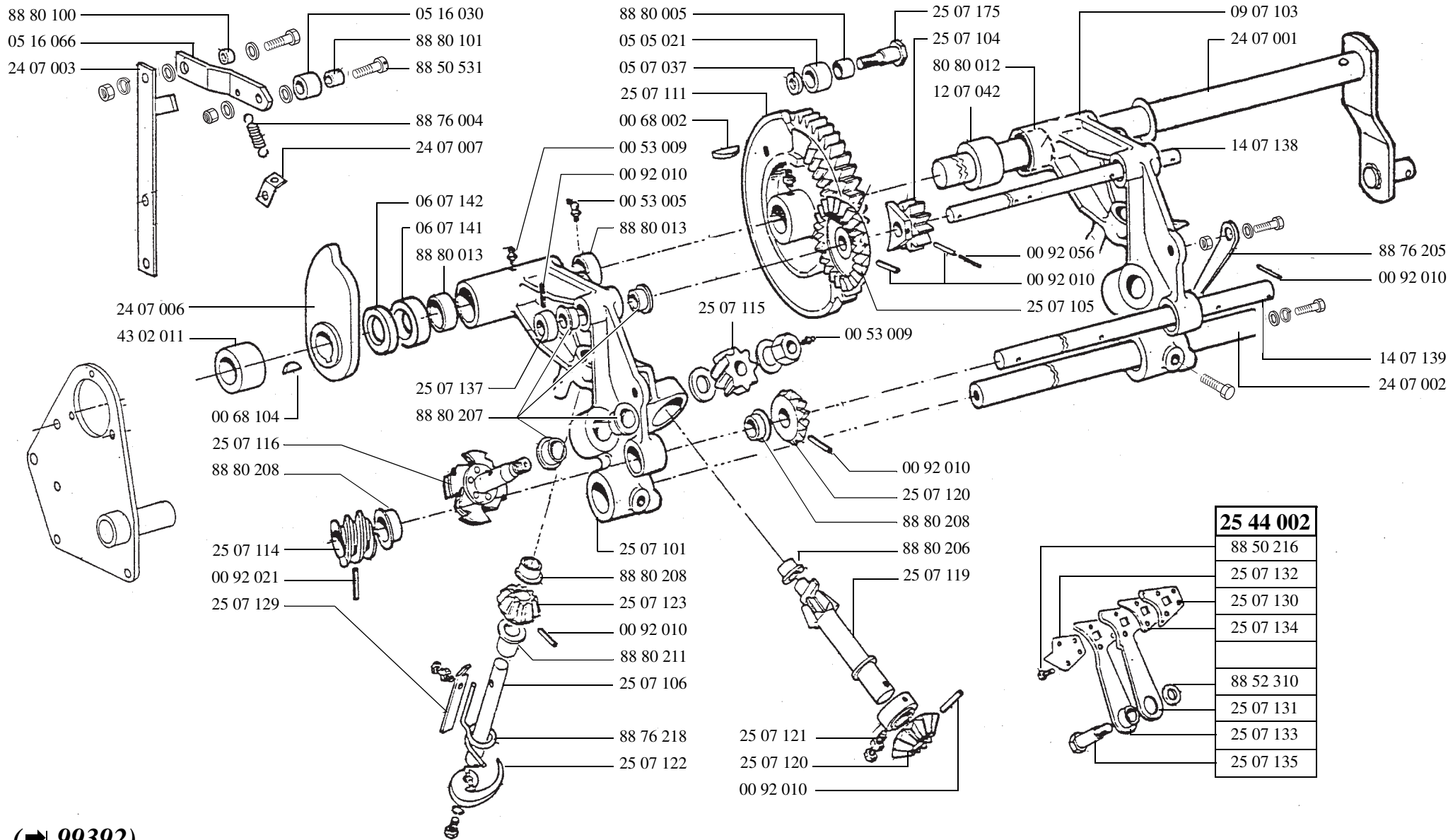

25 44 002
88 50 216
25 07 132
25 07 130
25 07 134
88 52 310
25 07 131
25 07 133
25 07 135

(→ 99392)

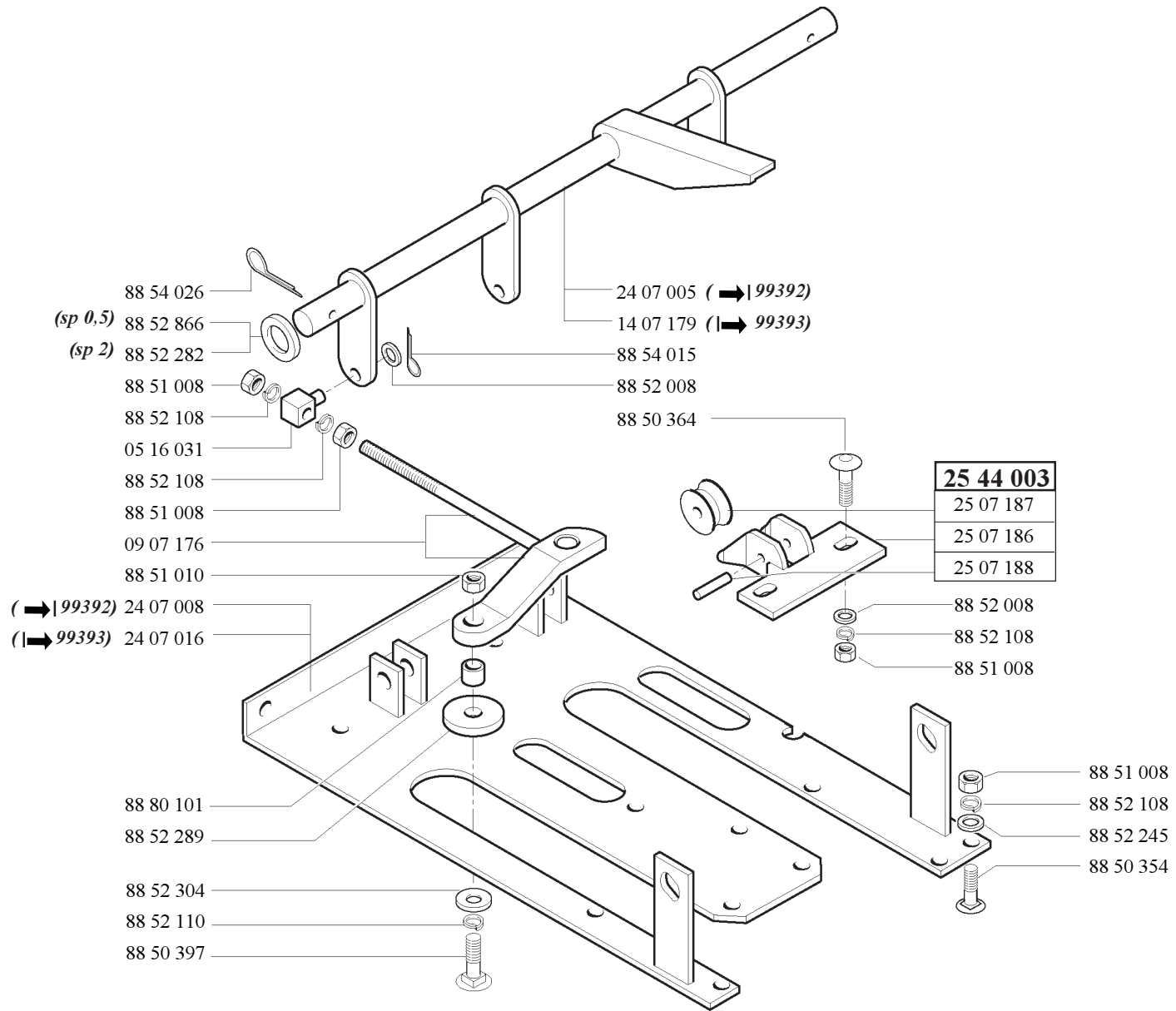

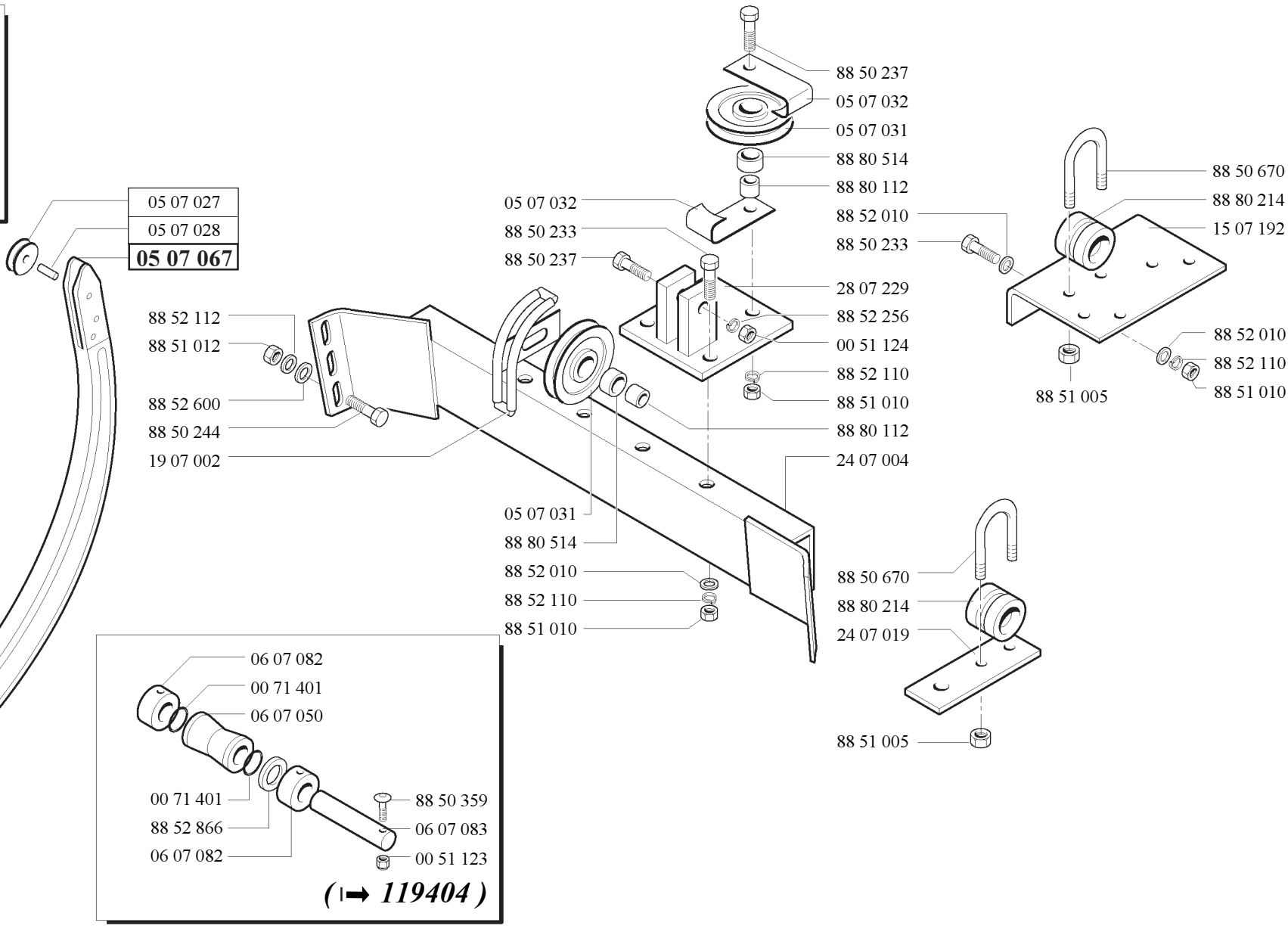
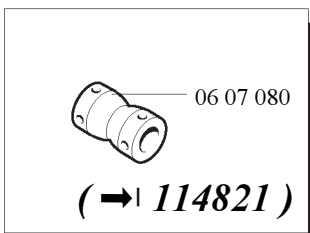
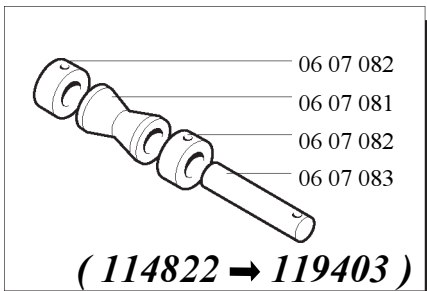

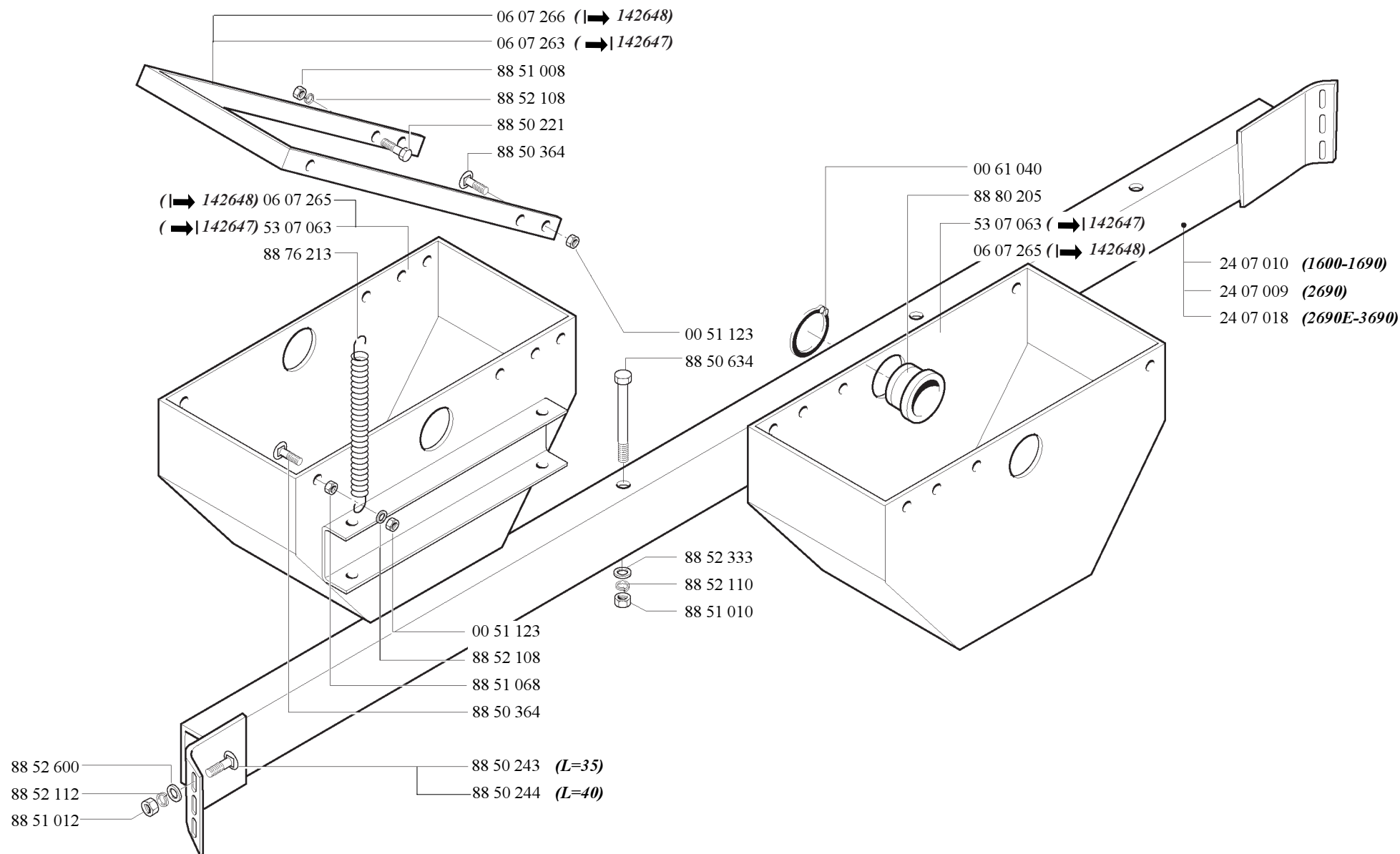

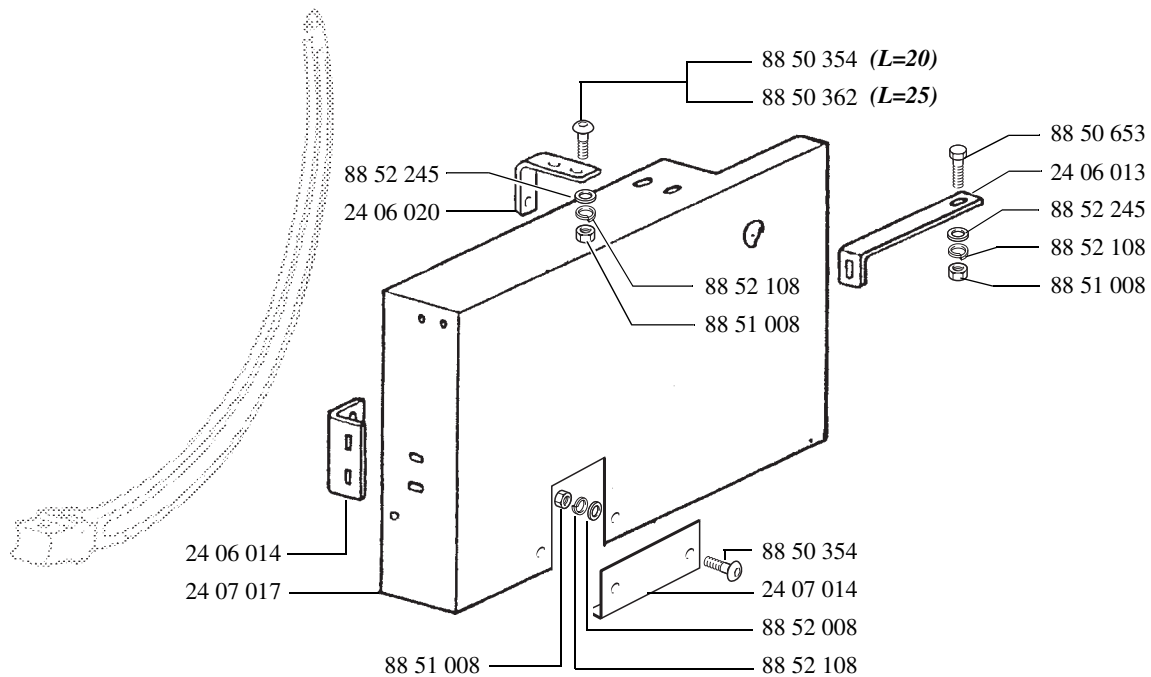
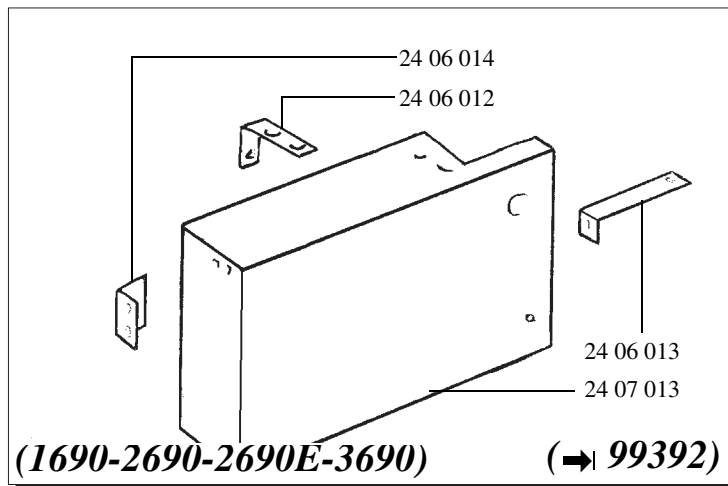

1690-2690-2690E-3690 (I→)

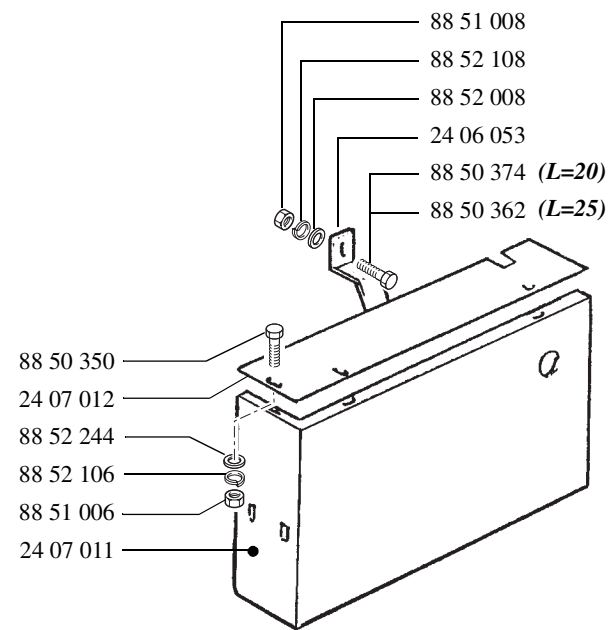

(1600)

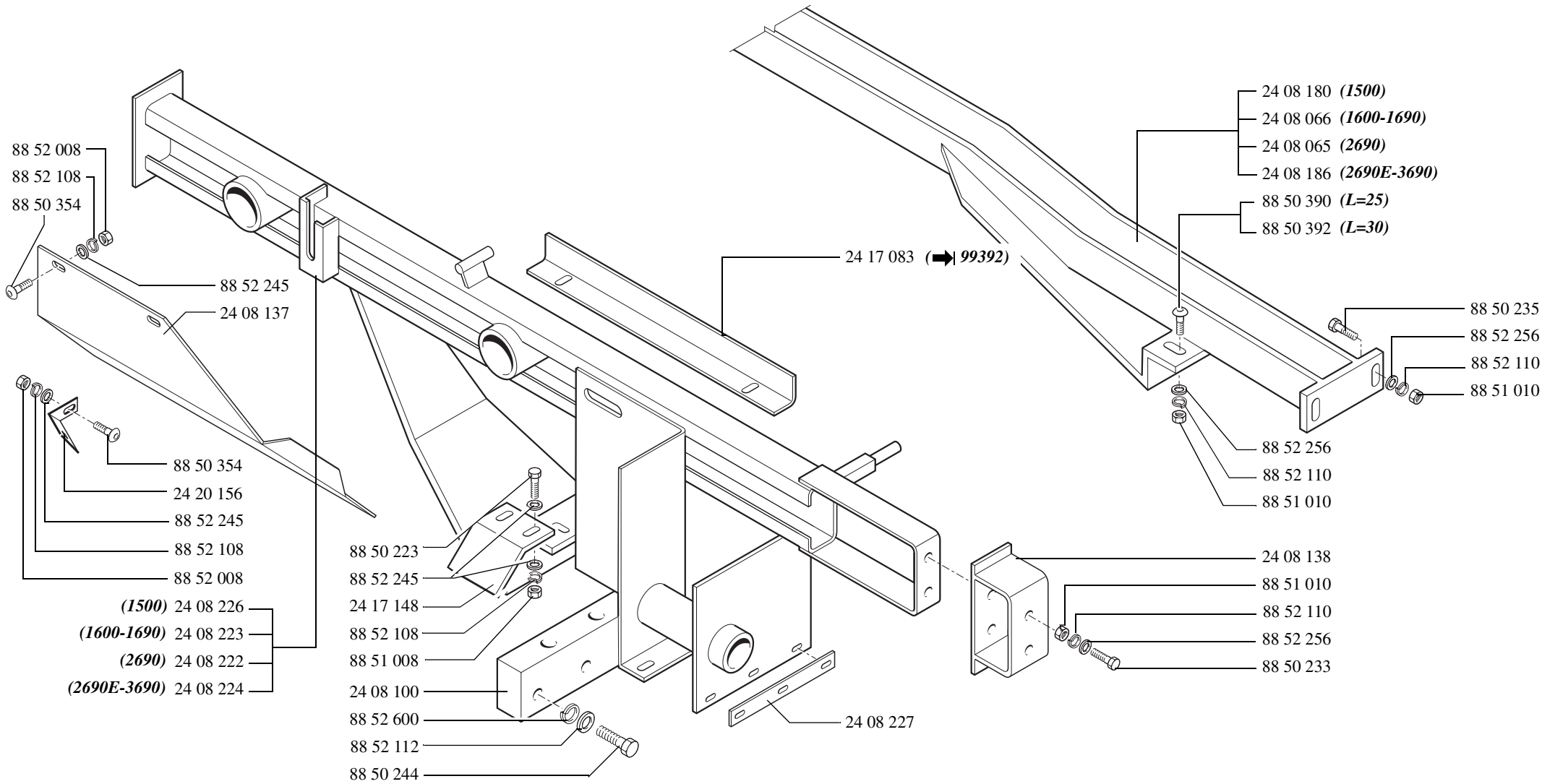

(I → 129343)

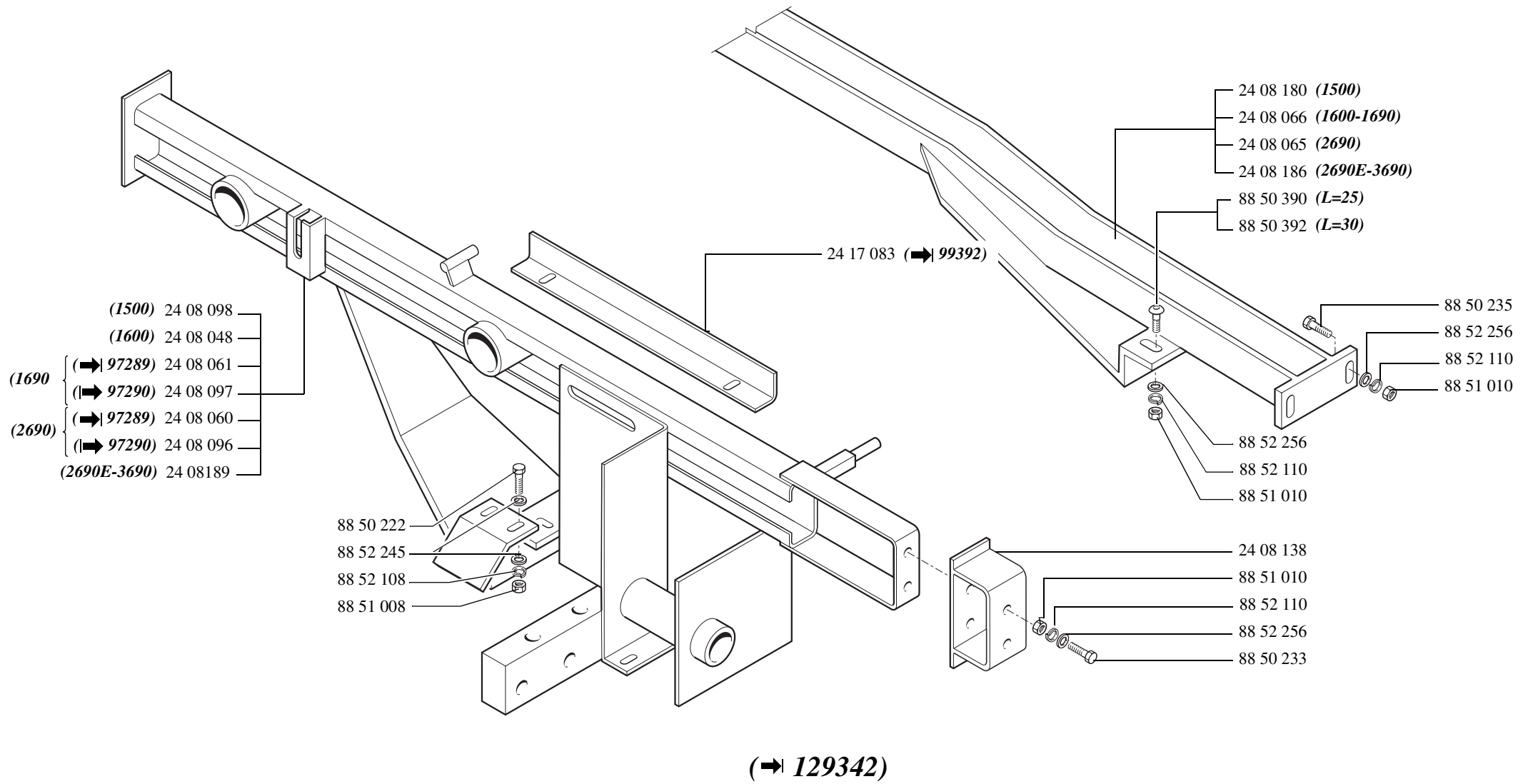

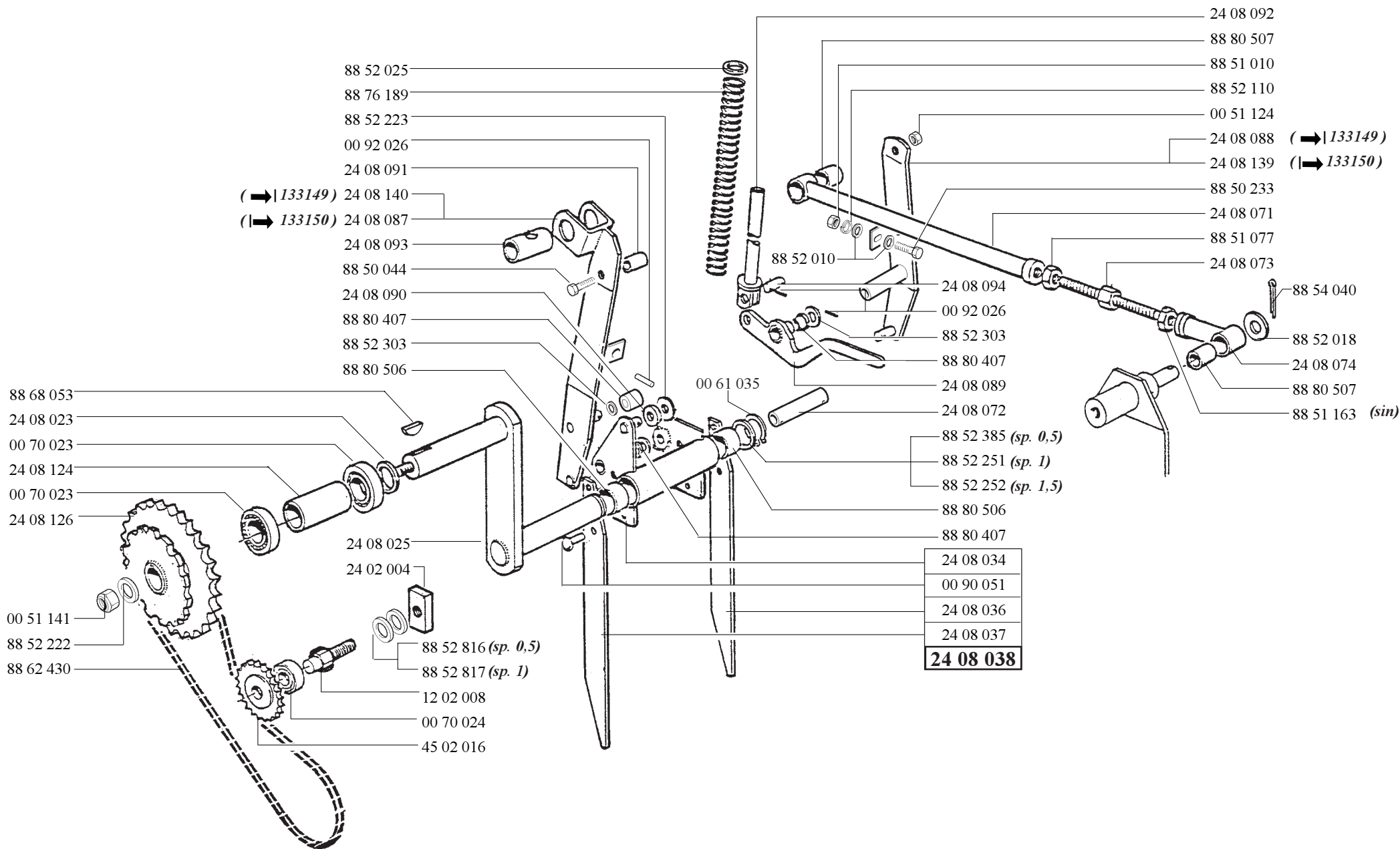

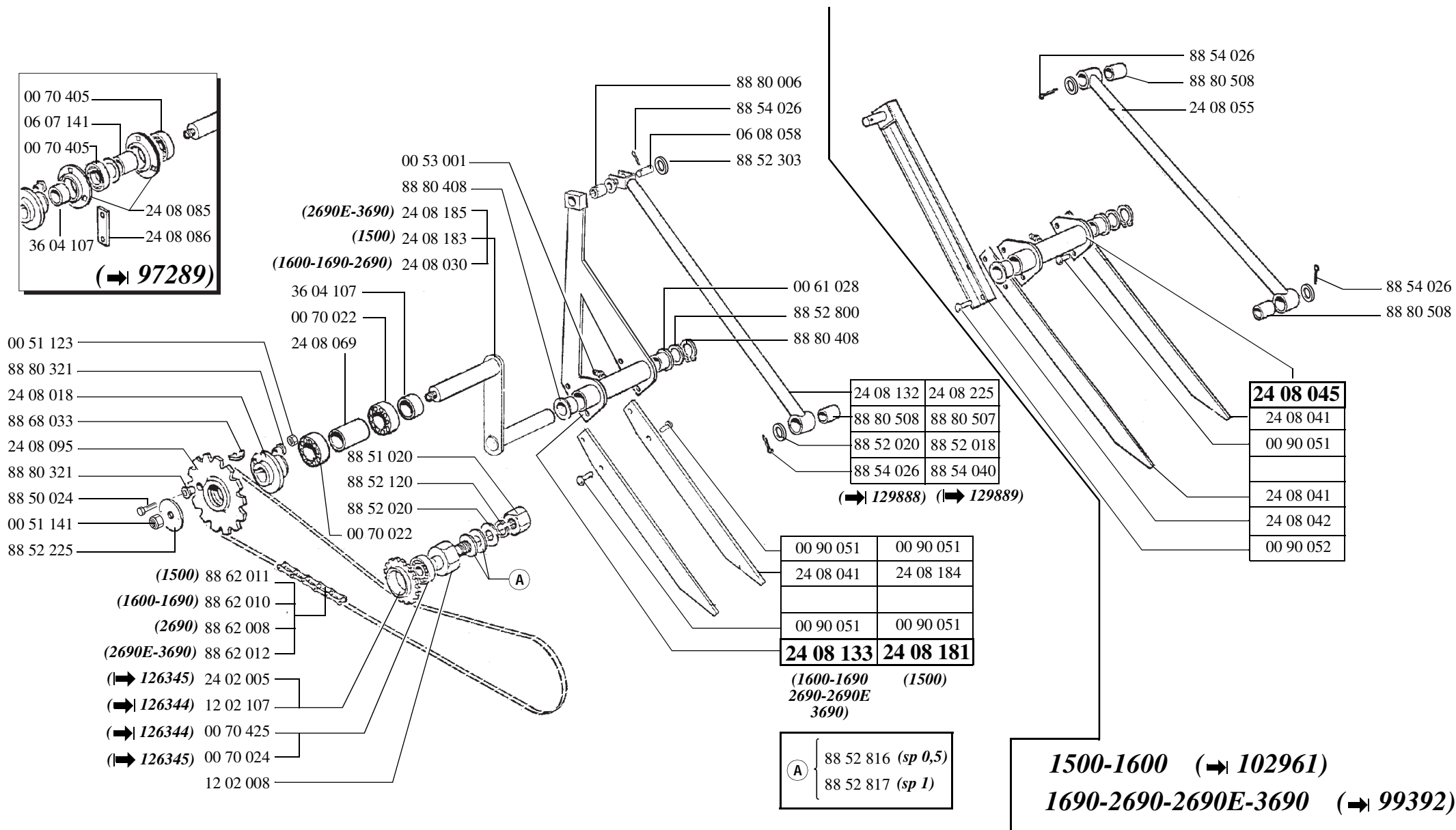
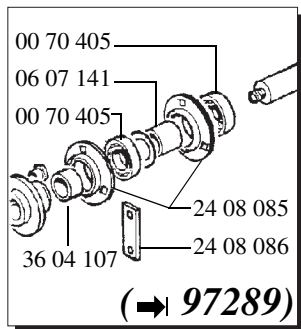

- 00 51 123
- 88 80 321
- 24 08 018
- 88 68 033
- 24 08 095
- 88 80 321
- 88 50 024
- 00 51 141
- 88 52 225
- (1500) 88 62 011
- (1600-1690) 88 62 010
- (2690) 88 62 008
- (2690E-3690) 88 62 012
- (→ 126345) 24 02 005
- (→ 126344) 12 02 107
- (→ 126344) 00 70 425
- (→ 126345) 00 70 024
- 12 02 008

- 00 53 001
- 88 80 408
- (2690E-3690) 24 08 185
- (1500) 24 08 183
- (1600-1690-2690) 24 08 030

- 36 04 107
- 00 70 022
- 24 08 069
- 88 51 020
- 88 52 120
- 88 52 020
- 00 70 022

- 88 80 006
- 88 54 026
- 06 08 058
- 88 52 303

- 00 61 028
- 88 52 800
- 88 80 408

24 08 132	24 08 225
88 80 508	88 80 507
88 52 020	88 52 018
88 54 026	88 54 040

(→ 129888) (→ 129889)

00 90 051	00 90 051
24 08 041	24 08 184
00 90 051	00 90 051
24 08 133	24 08 181

(1600-1690 2690-2690E 3690) (1500)

A	88 52 816 (sp 0,5)
	88 52 817 (sp 1)

- 88 54 026
- 88 80 508
- 24 08 055

- 88 54 026
- 88 80 508

24 08 045
24 08 041
00 90 051
24 08 041
24 08 042
00 90 052

1500-1600 (→ 102961)
 1690-2690-2690E-3690 (→ 99392)

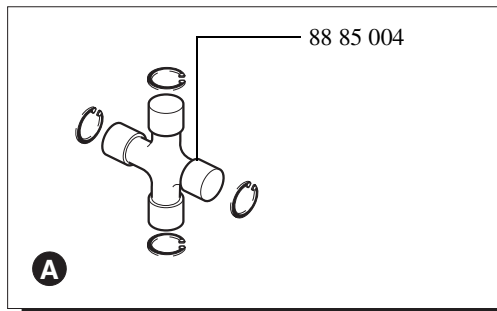
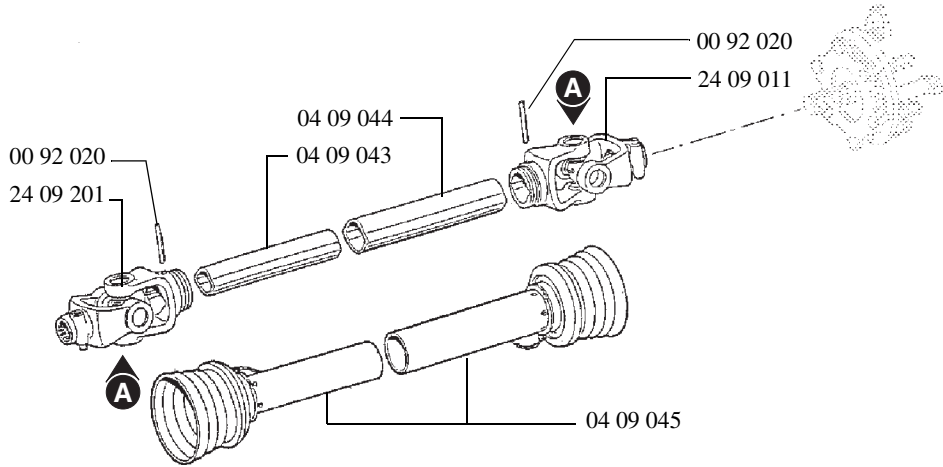

(→ 119404)

04 09 004

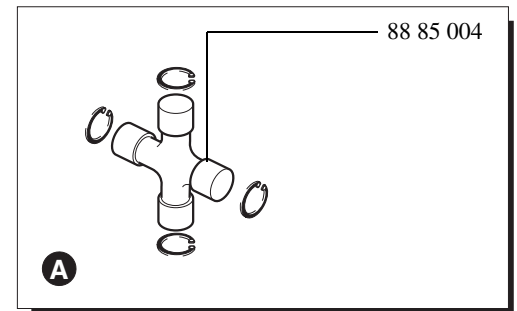
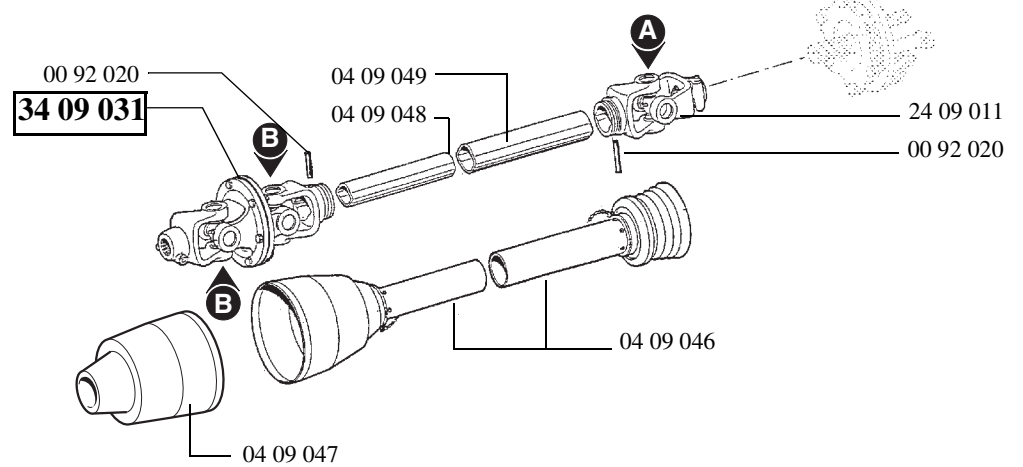

(→ 119404)

04 09 008

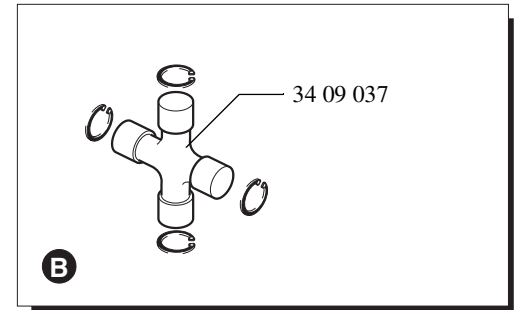

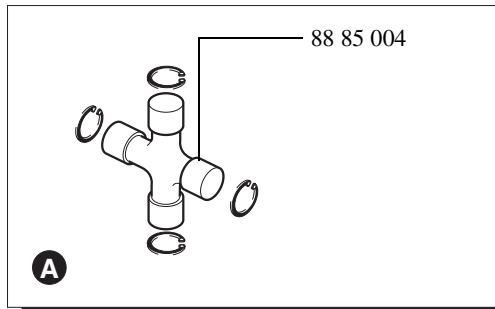
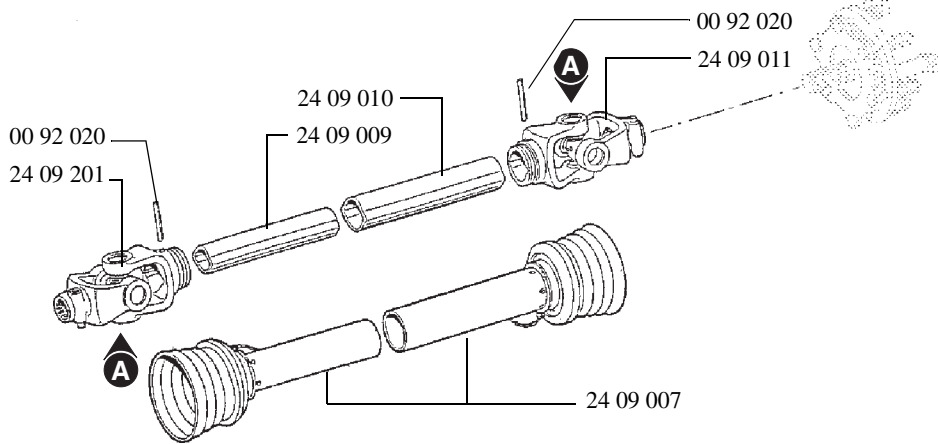

(→ 119403) **24 09 005**

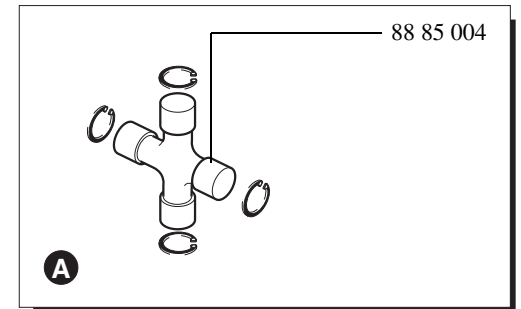
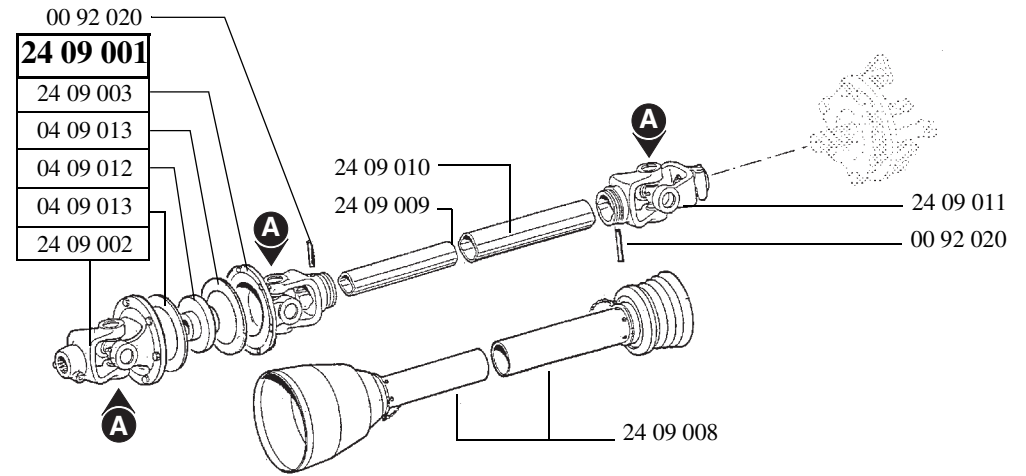

(→ 119403) **24 09 006**

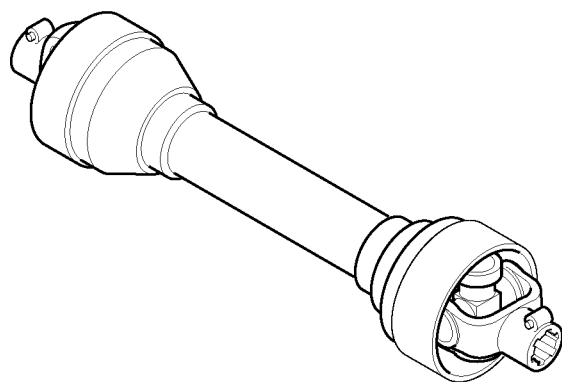

(→ 119404)

24 15 001

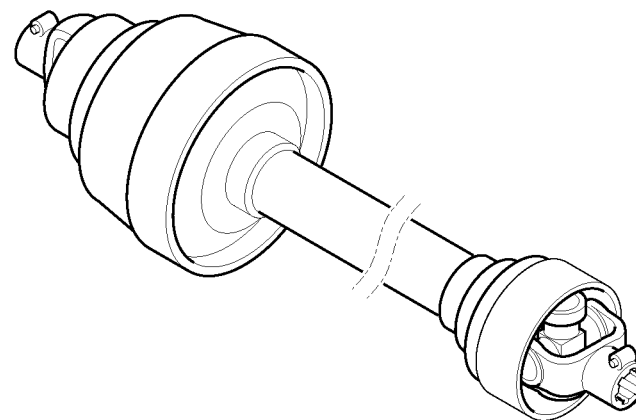

(→ 119404)

24 15 002

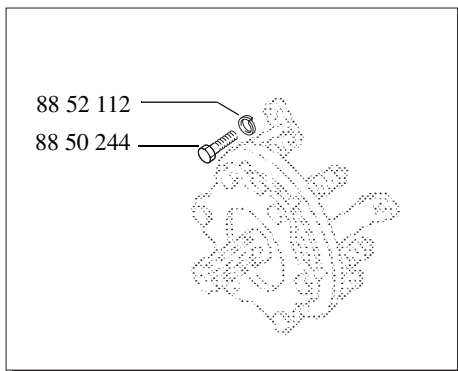

24 09 020

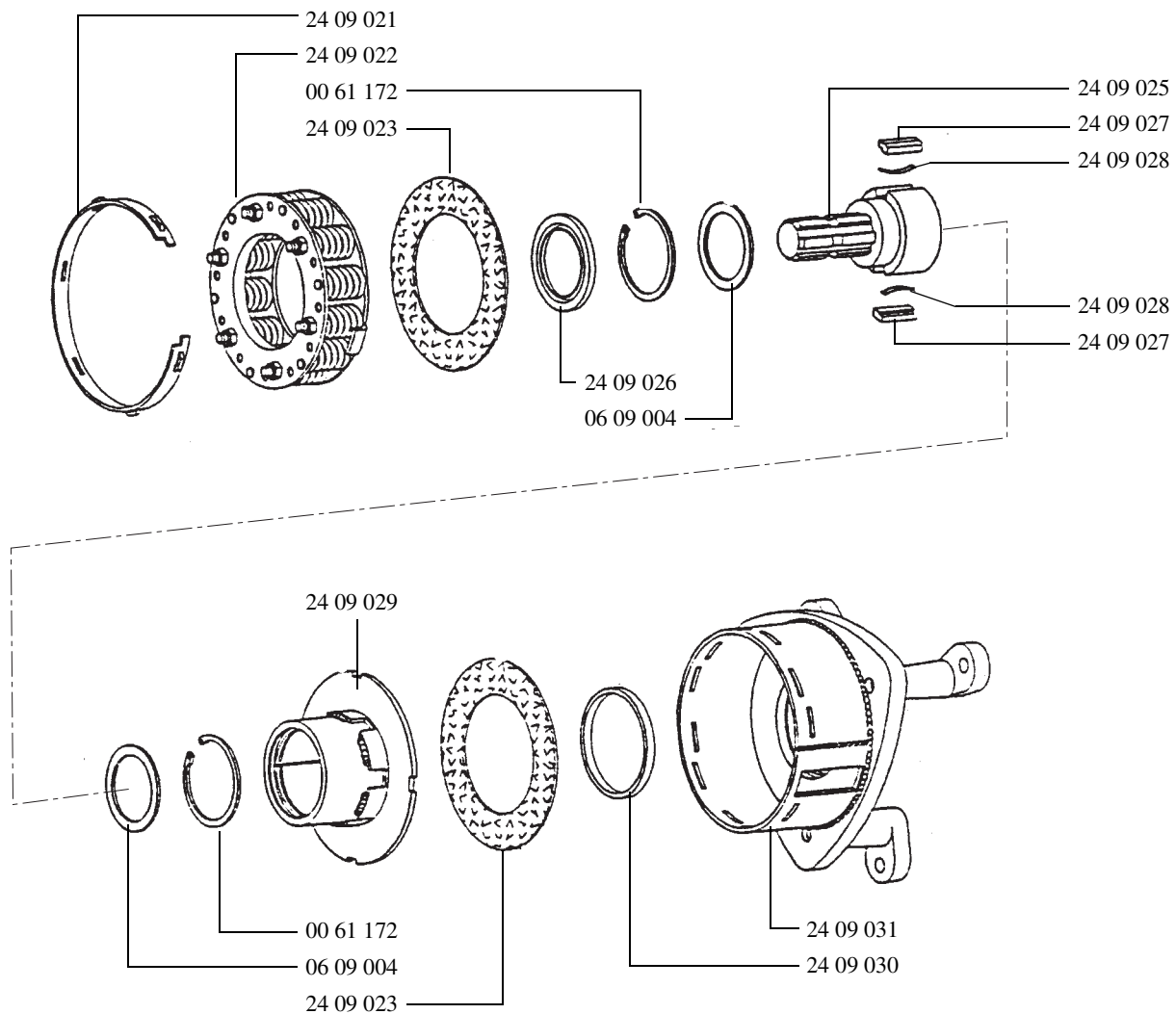

(→ 125489)

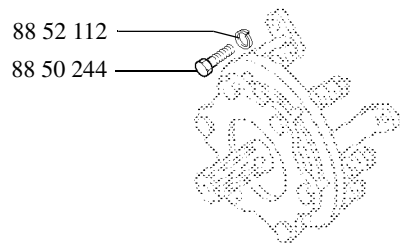

88 52 112
88 50 244

24 09 004

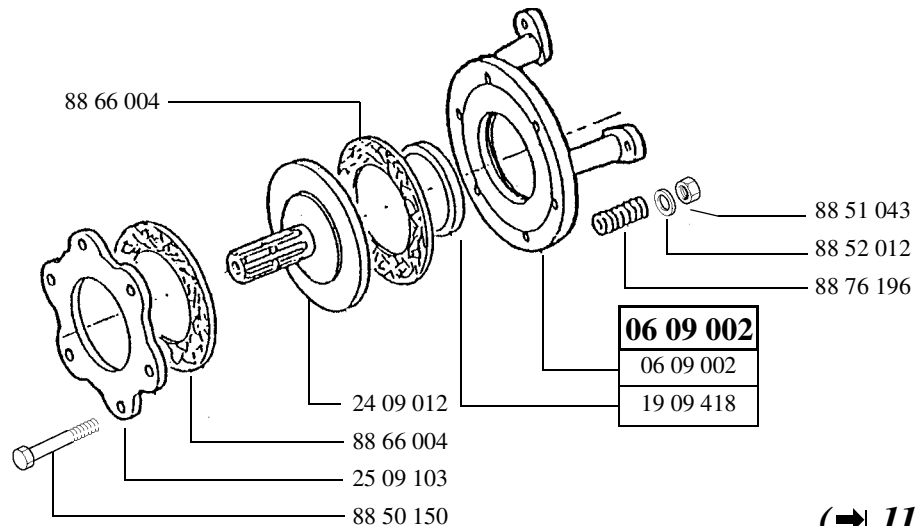

88 66 004

88 51 043
88 52 012
88 76 196

06 09 002
06 09 002
19 09 418

24 09 012
88 66 004
25 09 103
88 50 150

(→ 112002)

24 09 016

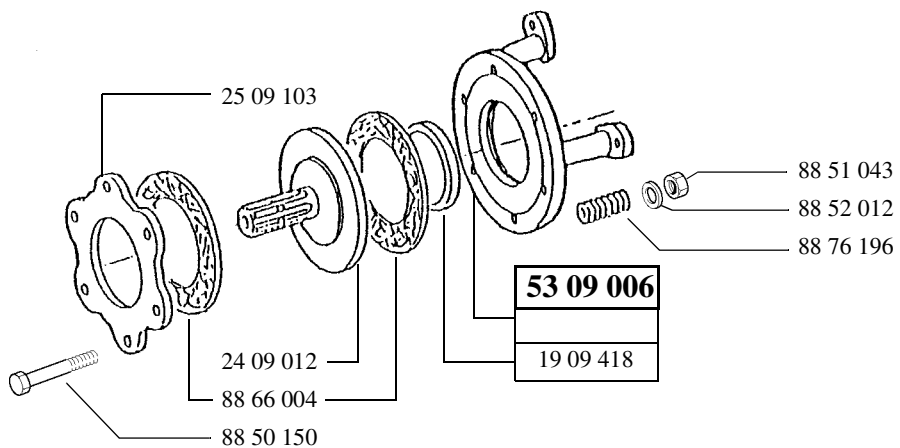

25 09 103

88 51 043
88 52 012
88 76 196

53 09 006
19 09 418

24 09 012
88 66 004
88 50 150

(→ 122286)

24 09 017

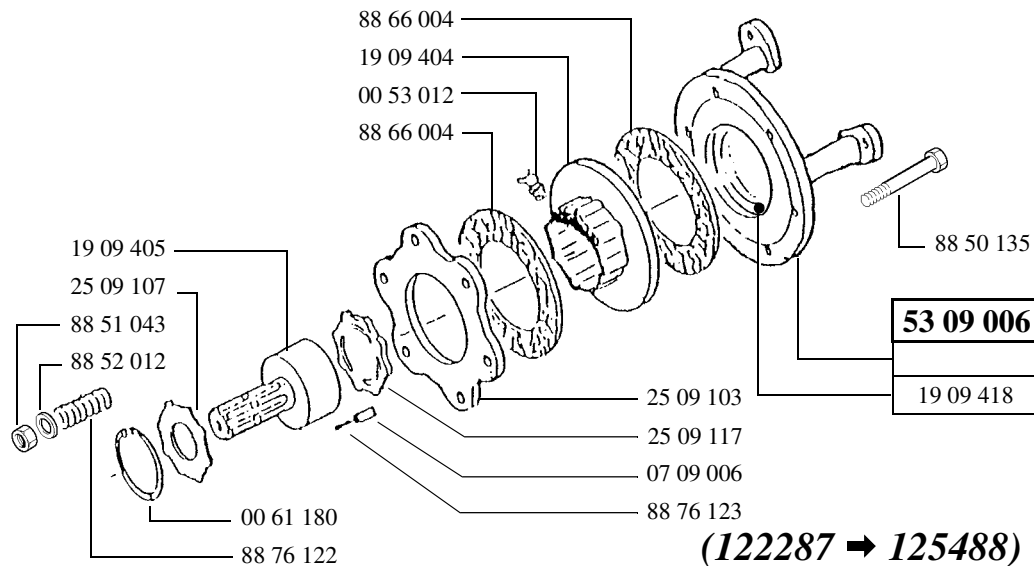

88 66 004
19 09 404
00 53 012
88 66 004

88 50 135

53 09 006
19 09 418

19 09 405
25 09 107
88 51 043
88 52 012
00 61 180
88 76 122

25 09 103
25 09 117
07 09 006
88 76 123

(122287 → 125488)

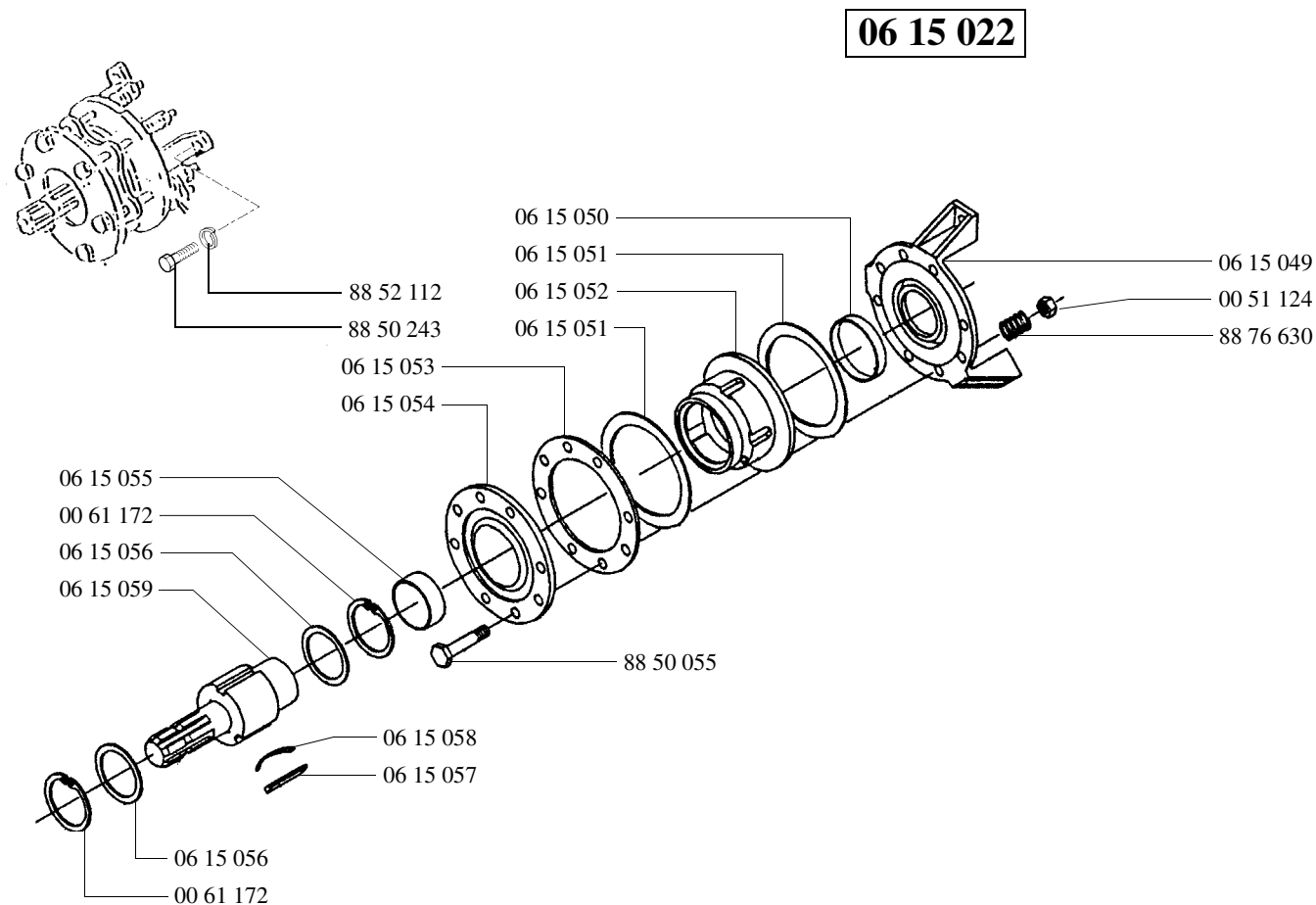

(I→ 125489)

A 88 52 355 (sp 0,5)
88 52 025 (sp 3)

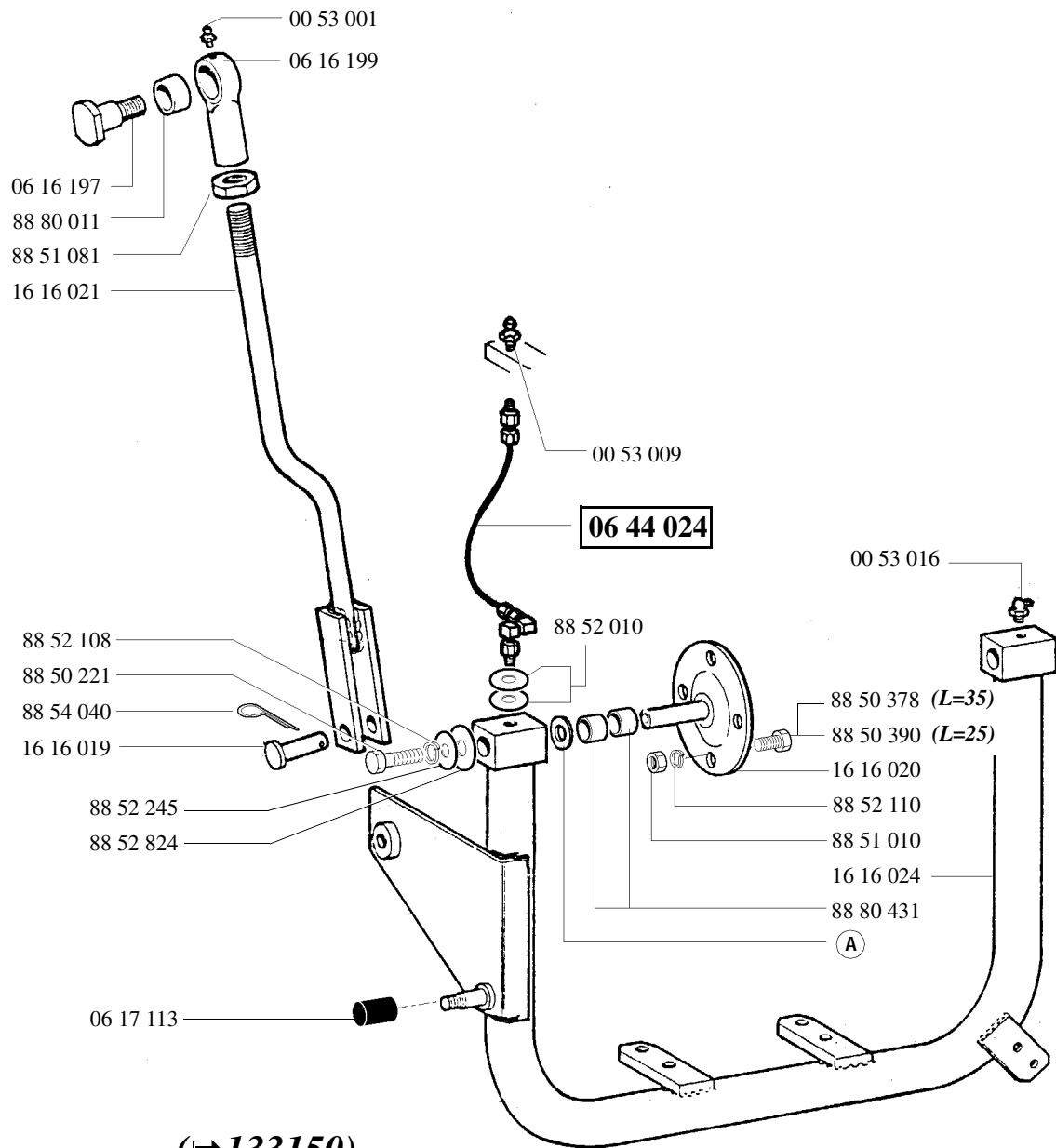

(→133150)

(A) 88 52 309 (sp 1,5)
88 52 200 (sp 3)

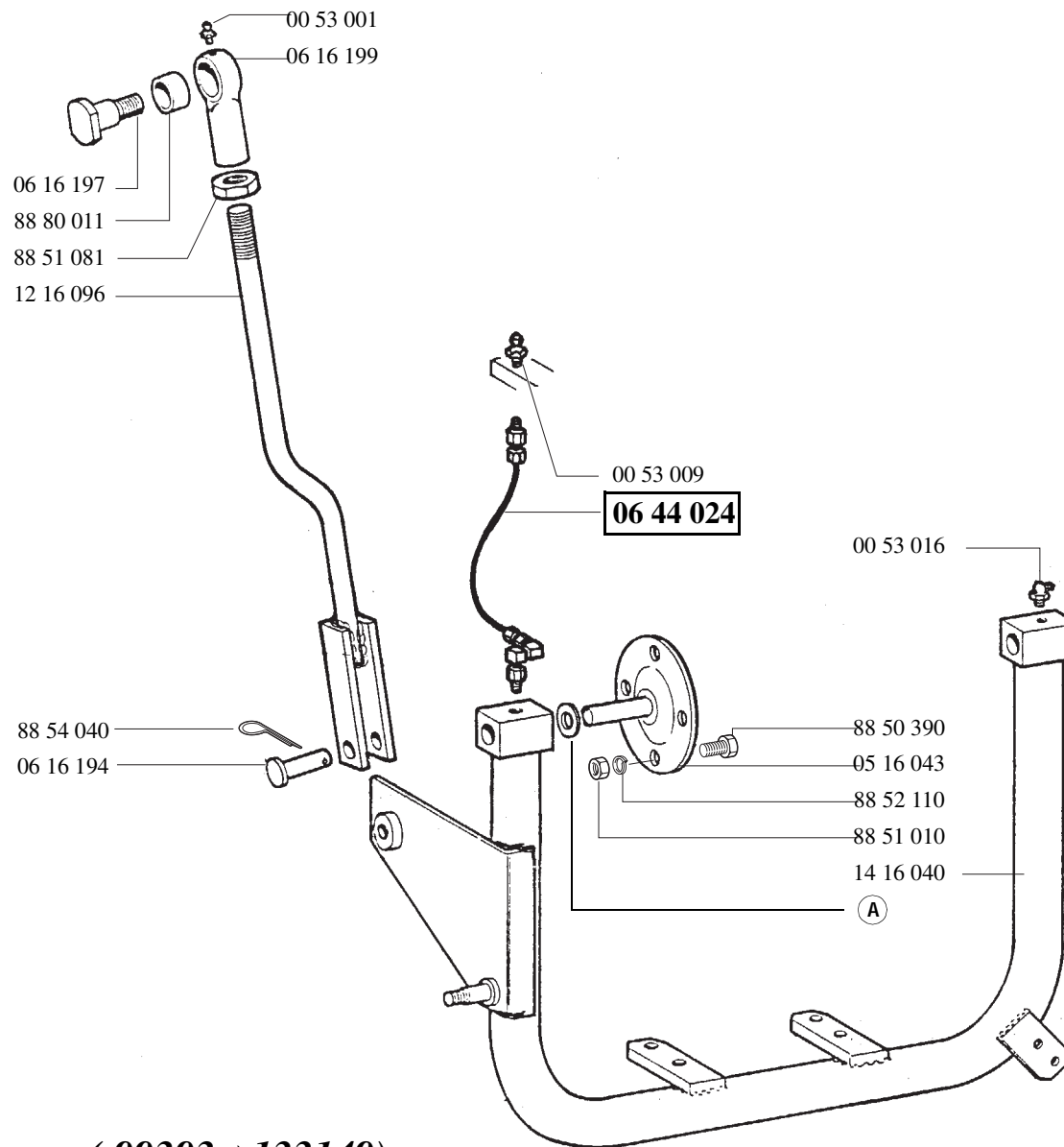

(99393 → 133149)

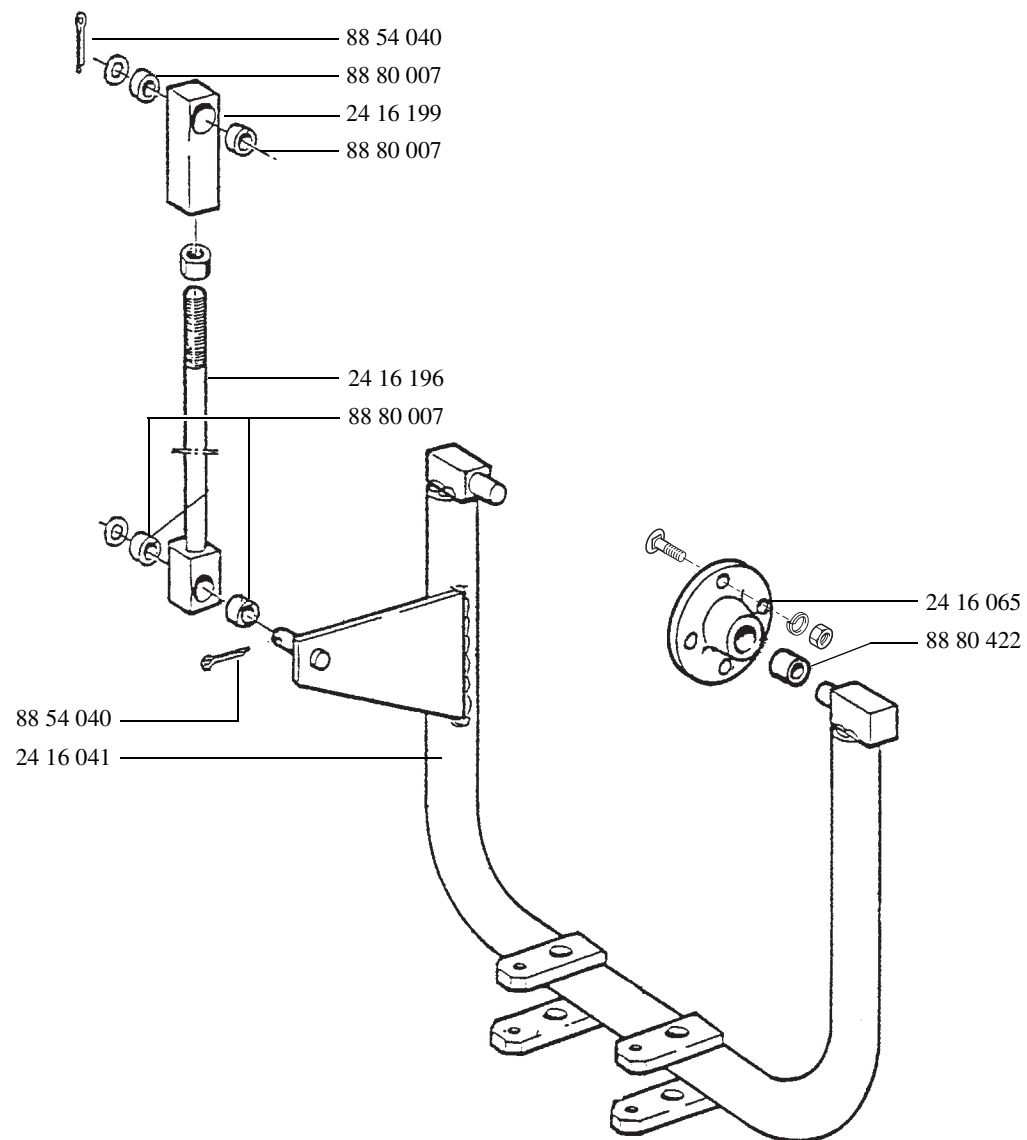

(→ 99392)

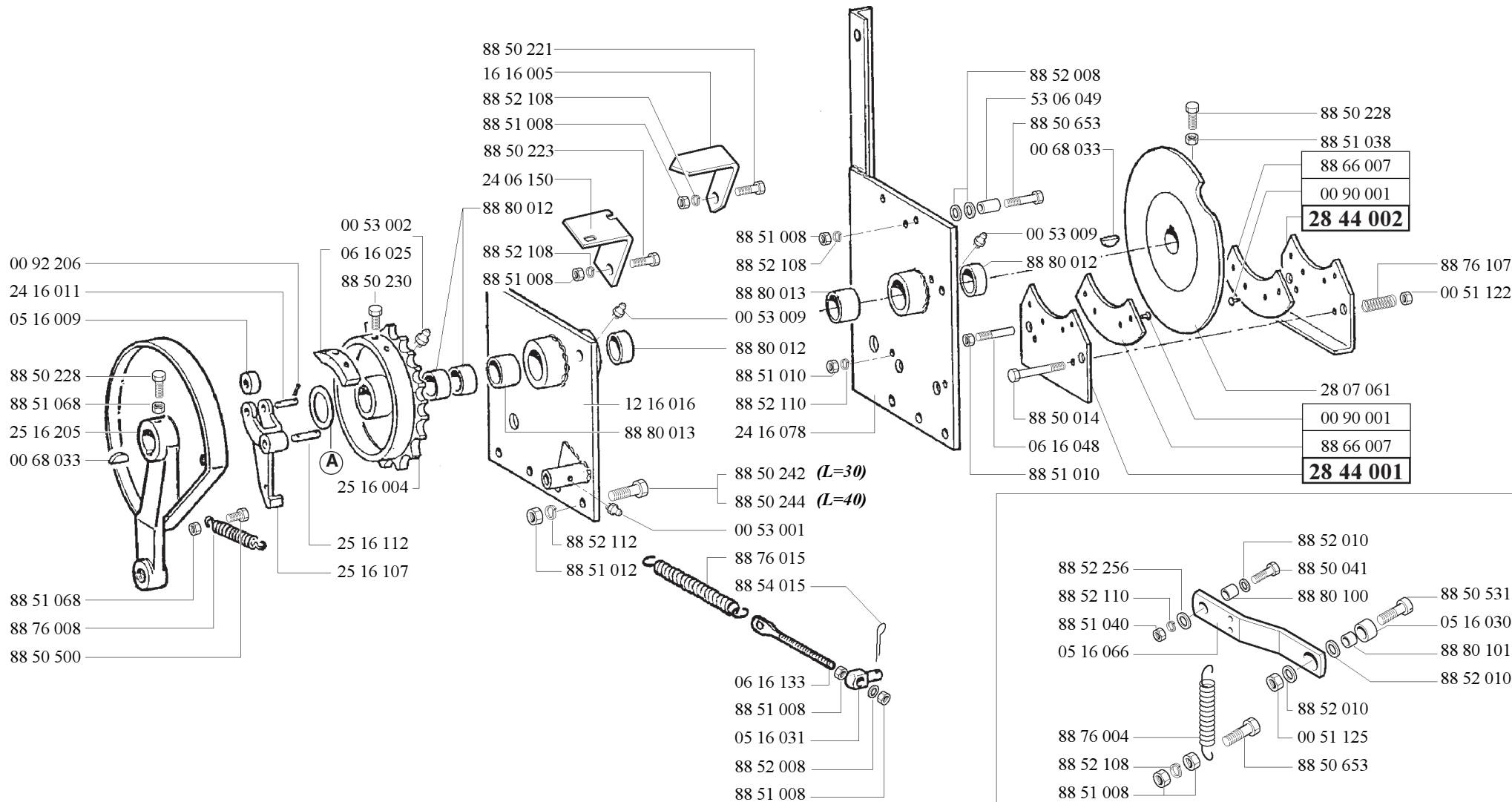

A { 88 52 374 (sp 0,5)
88 52 205 (sp 1)

(1 → 99393)

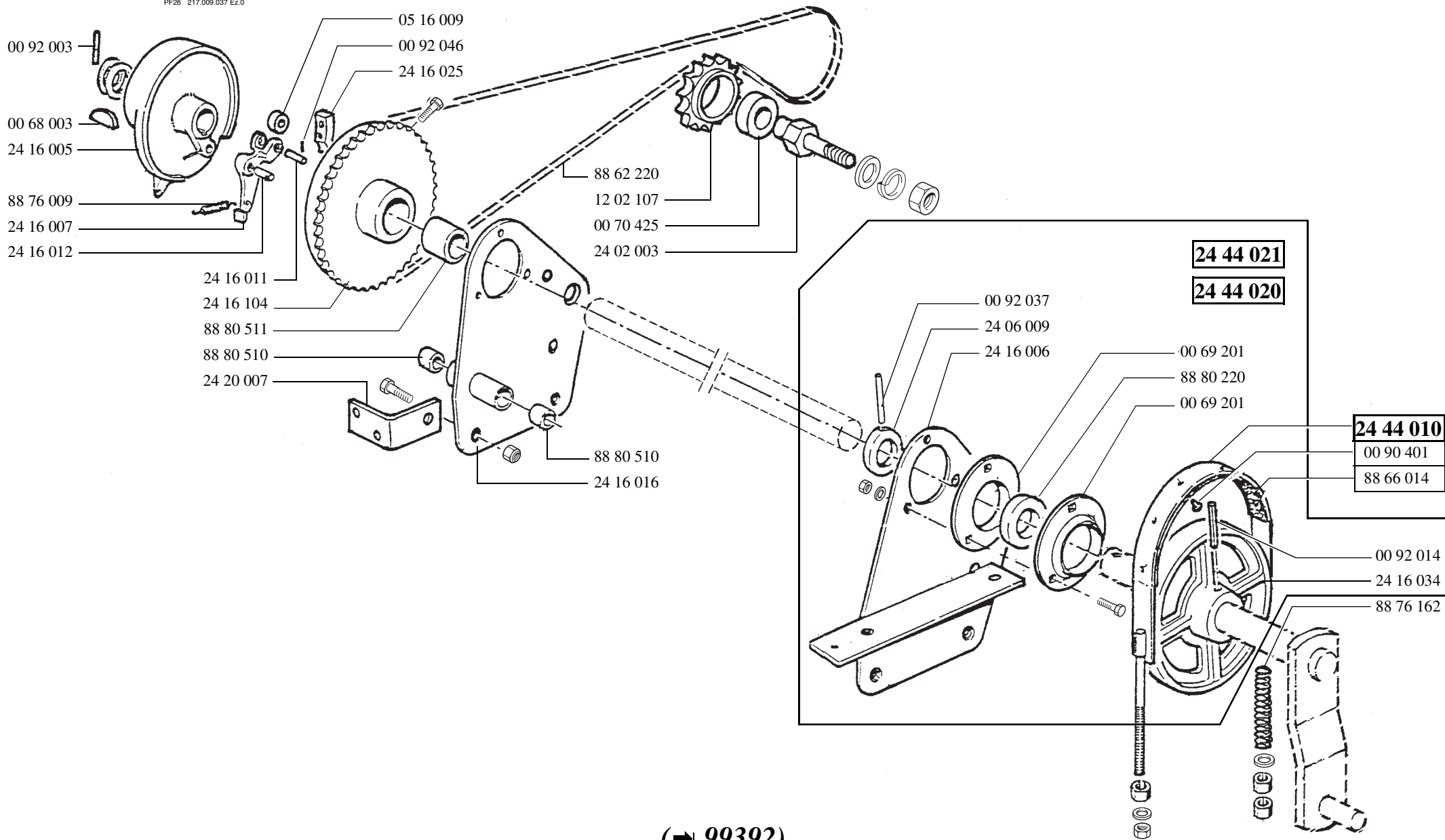

(→ 99392)

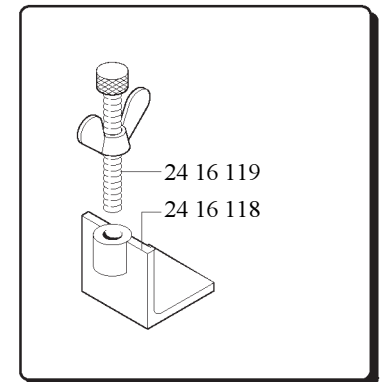
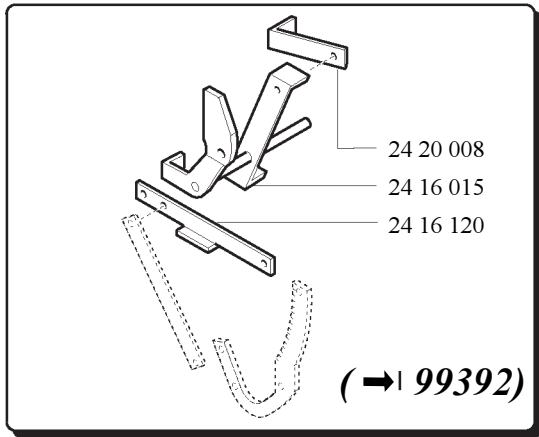
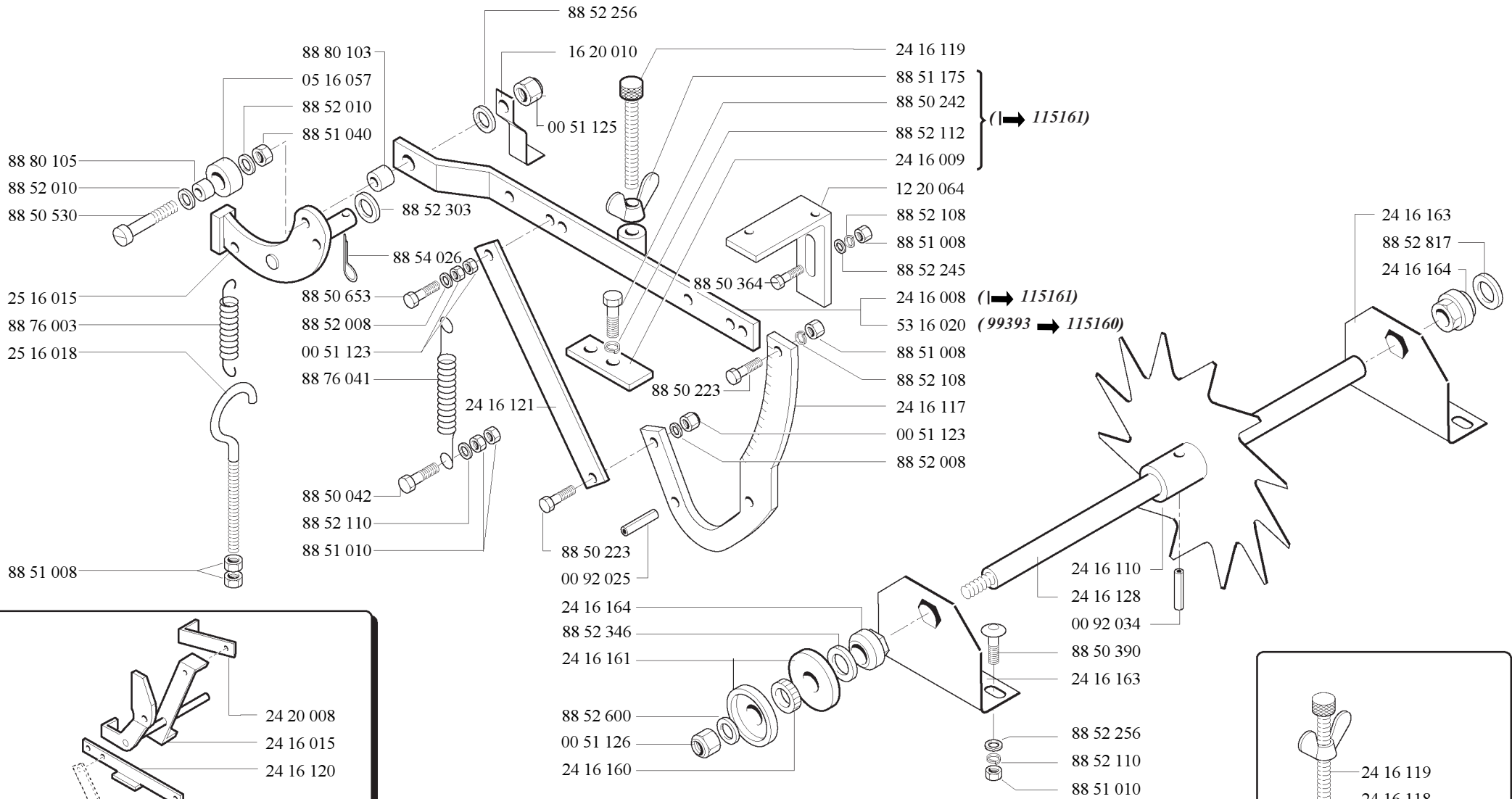

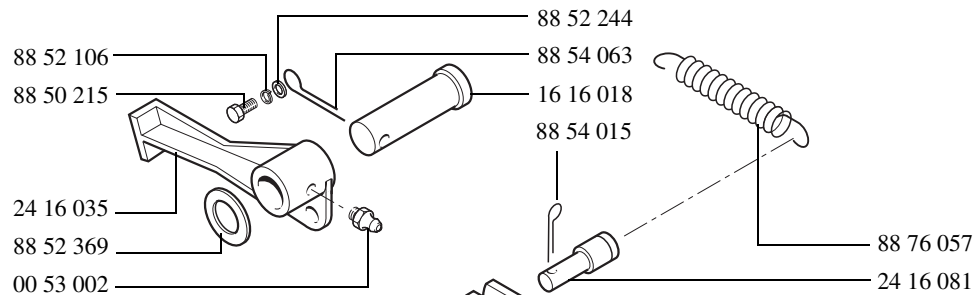

(⇒ 99393)

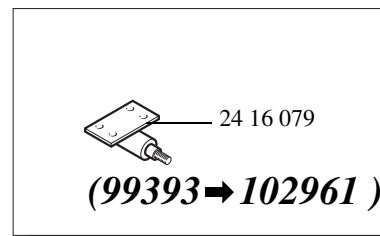
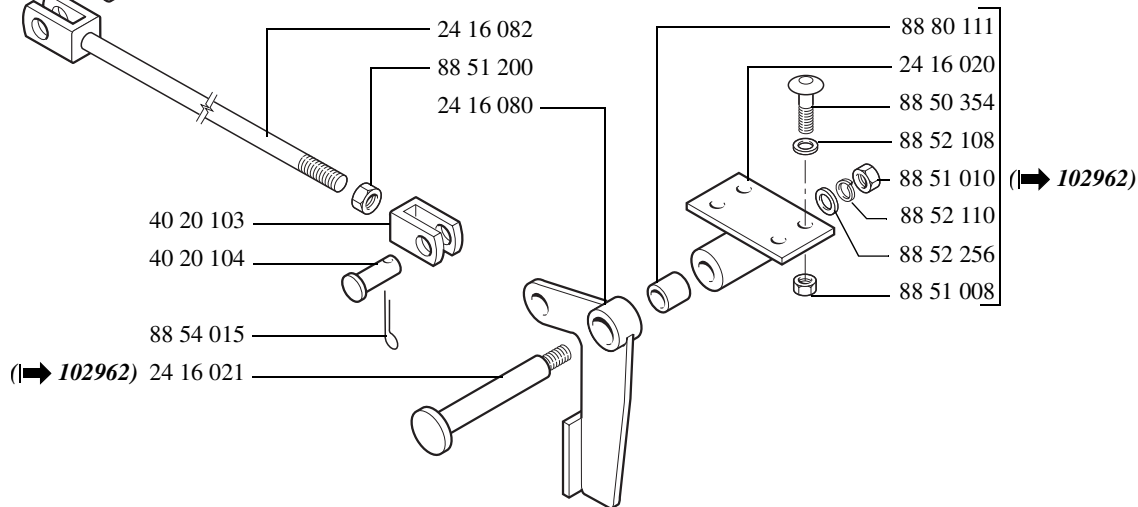
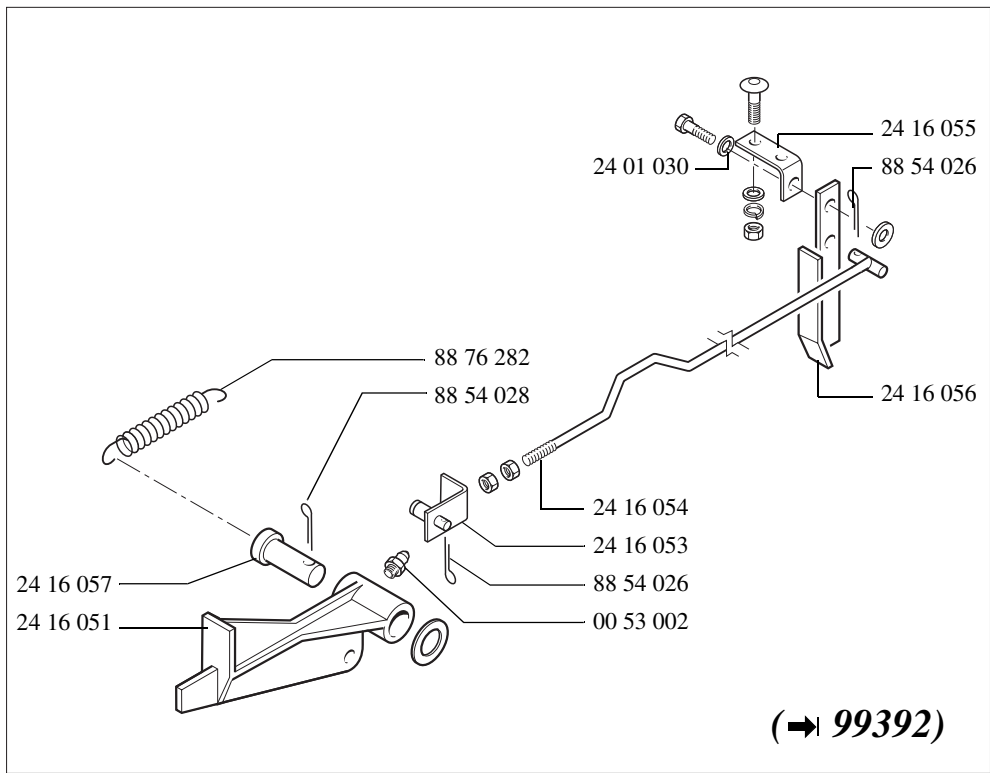

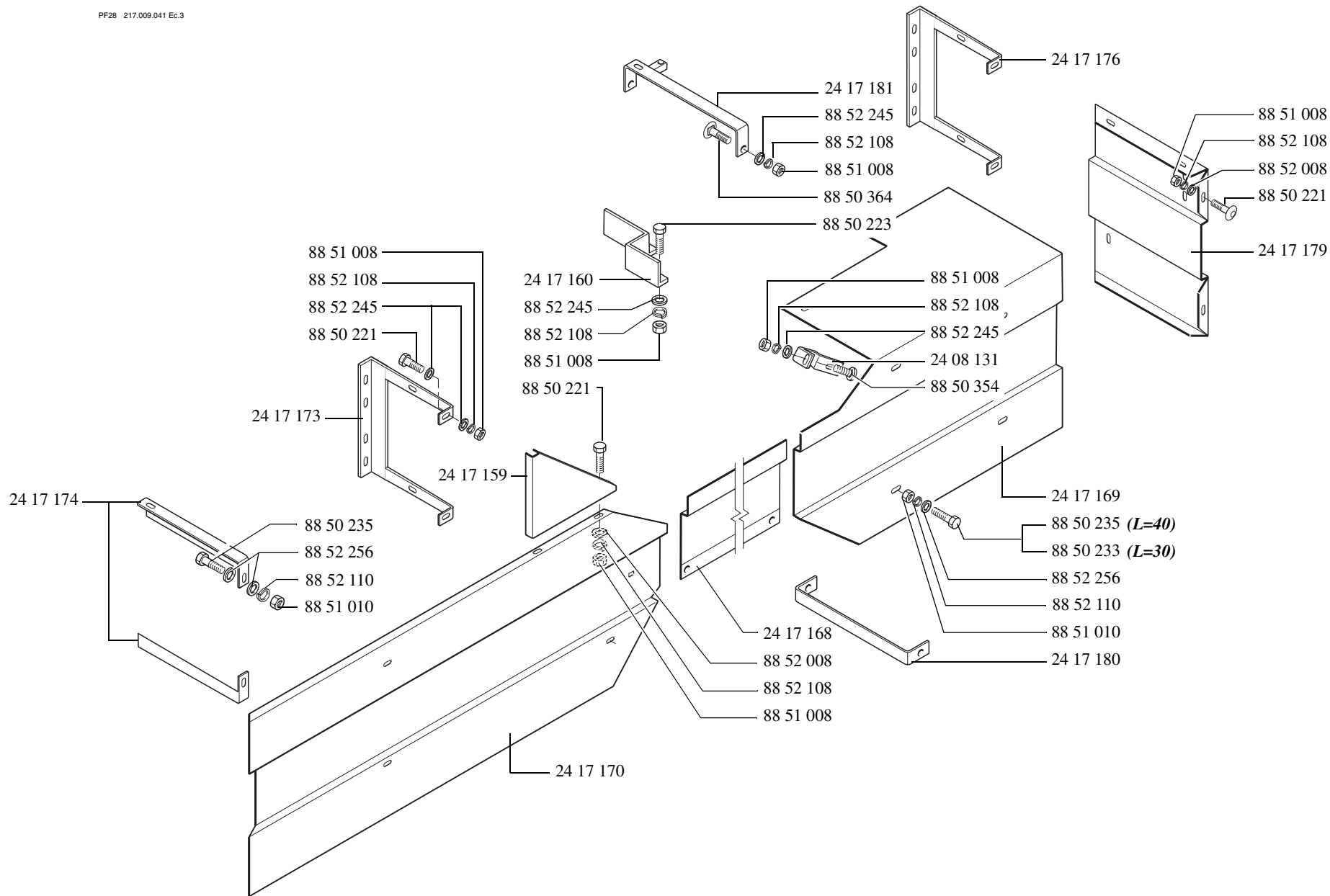

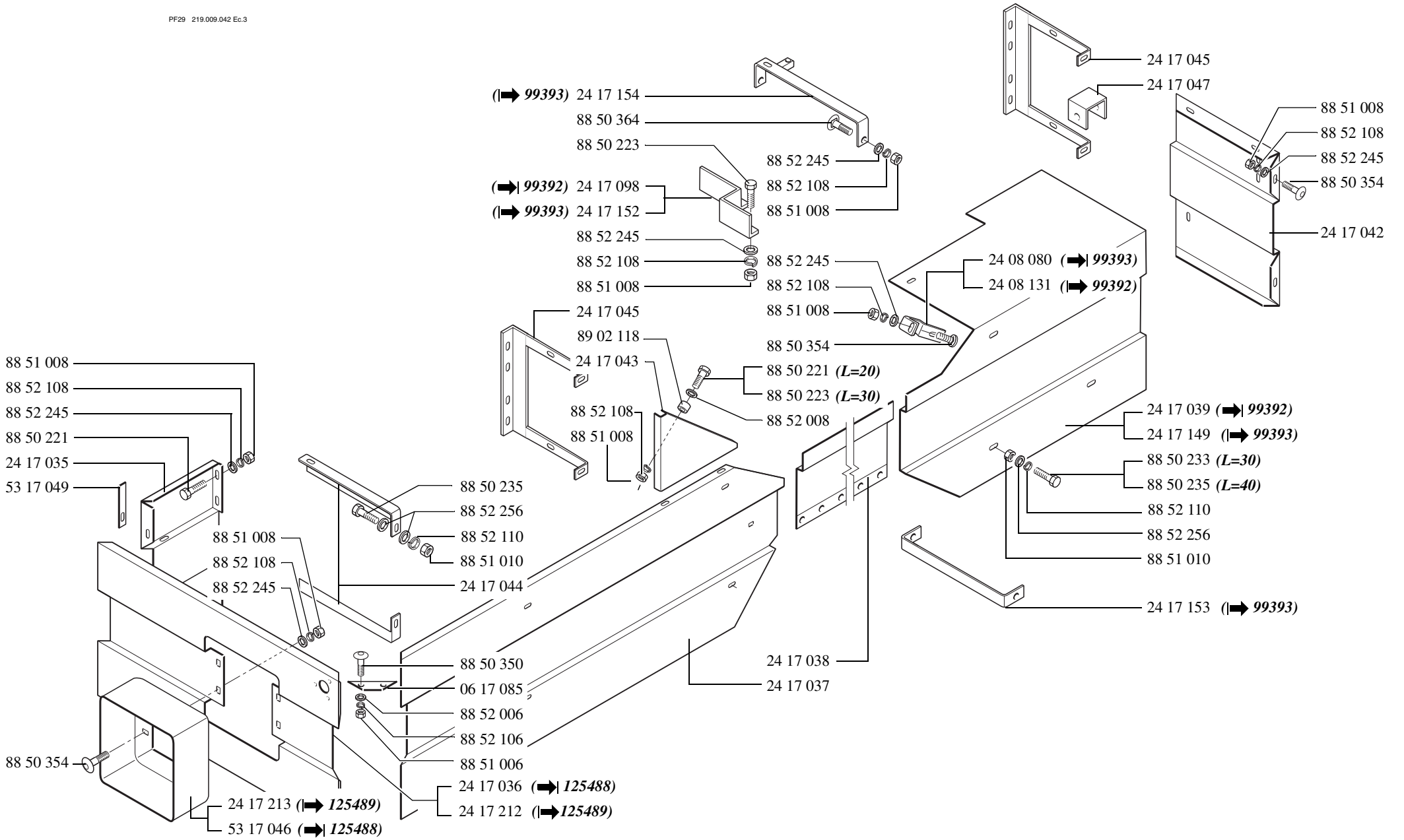

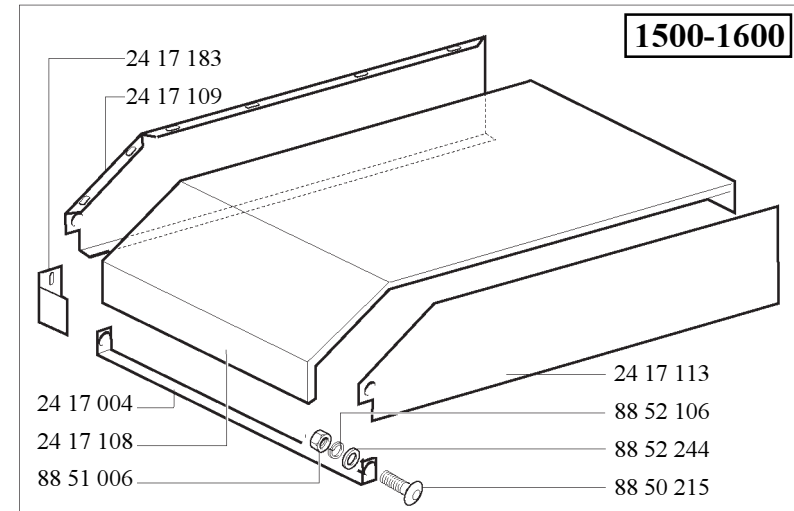
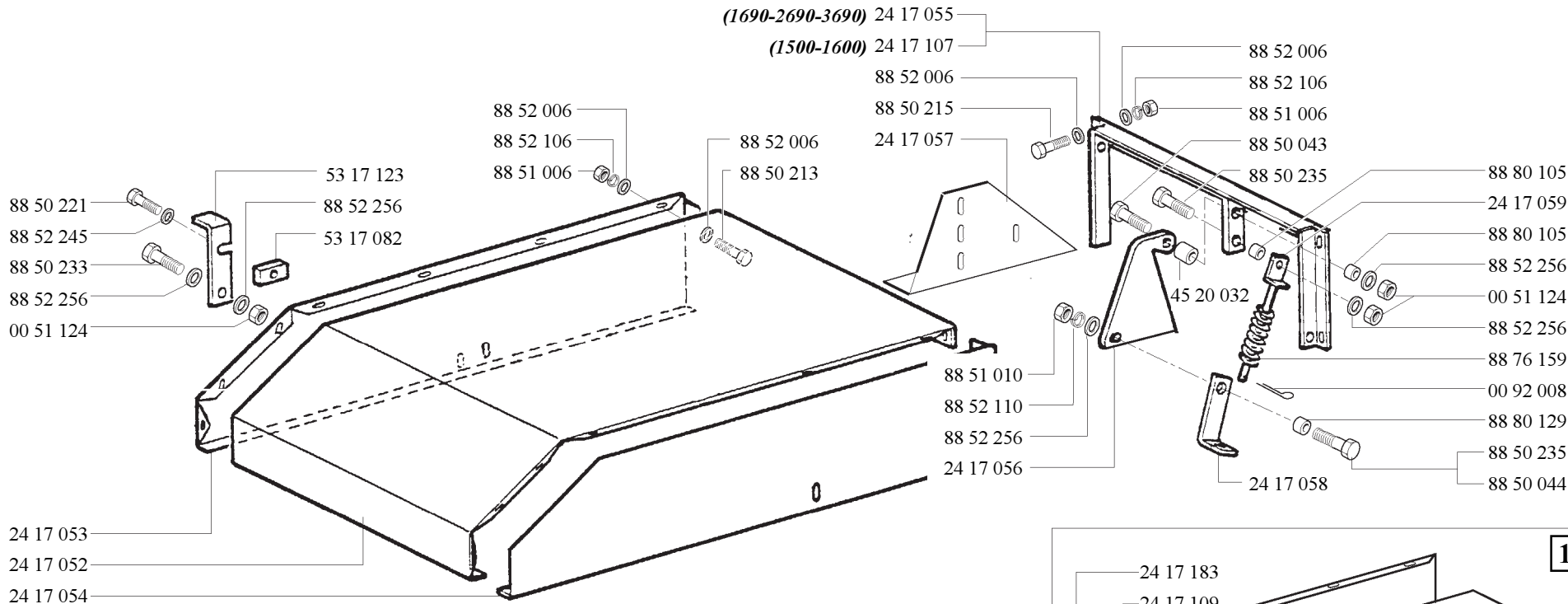

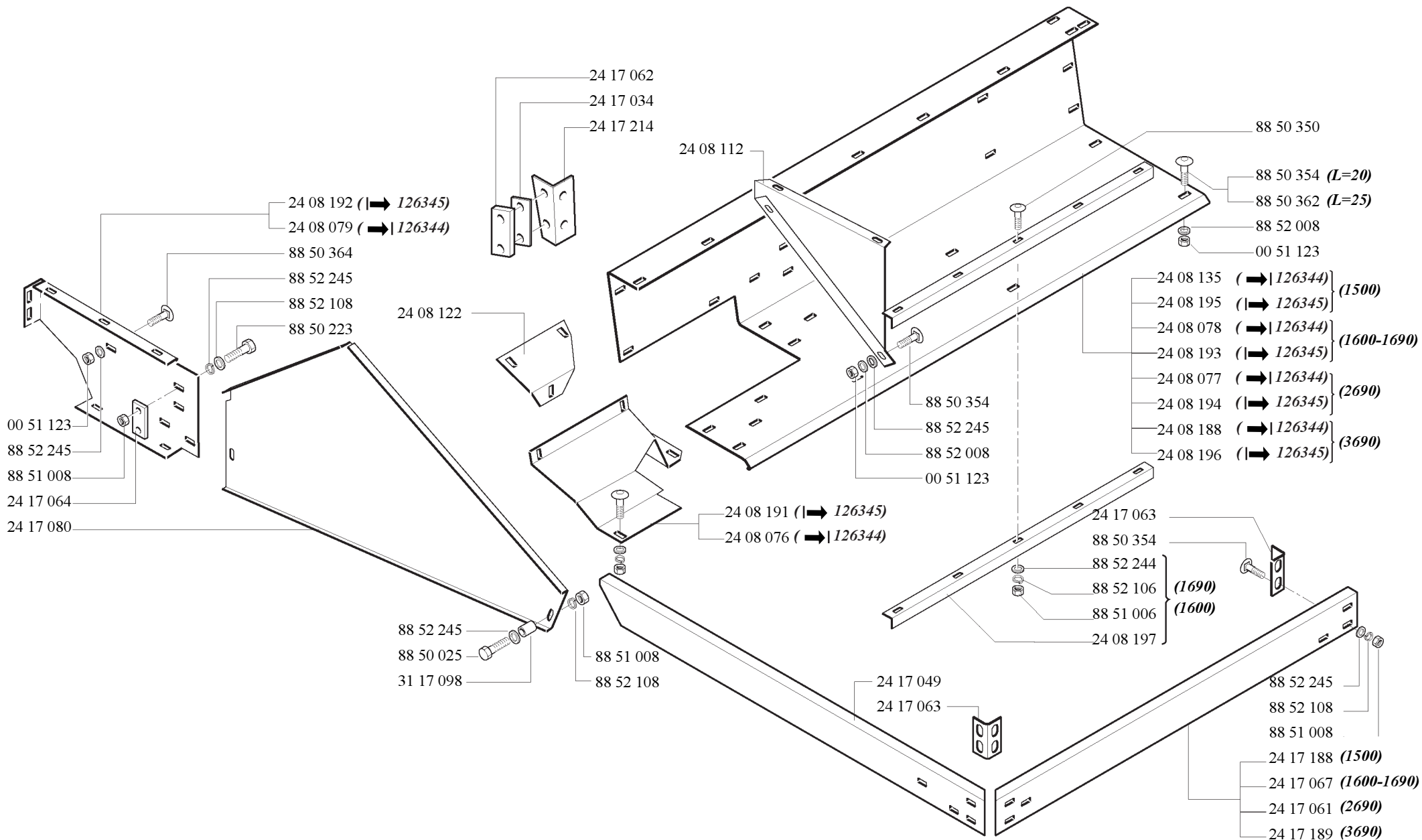

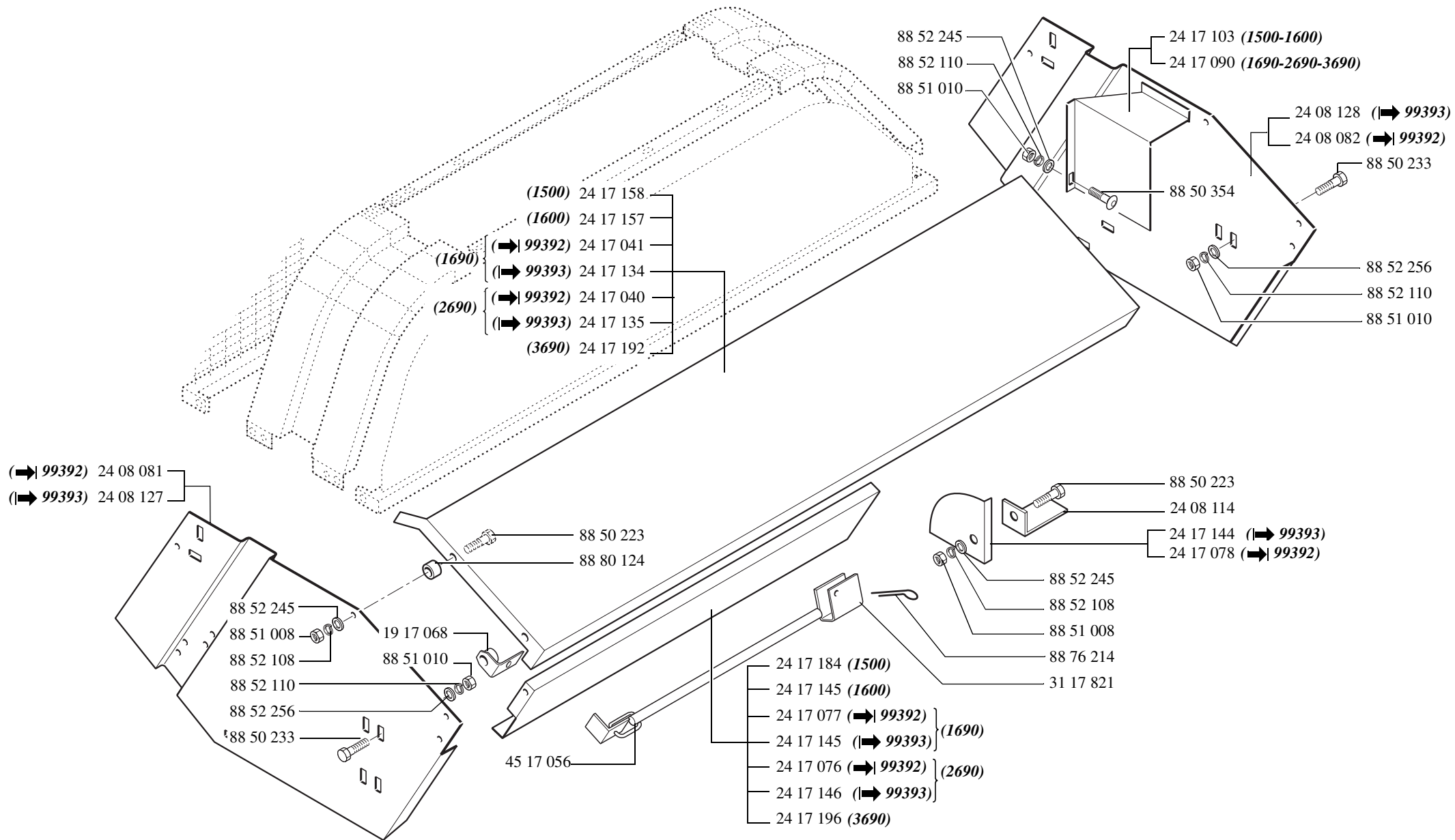

24 44 037 (1500)
24 44 038 (1600)

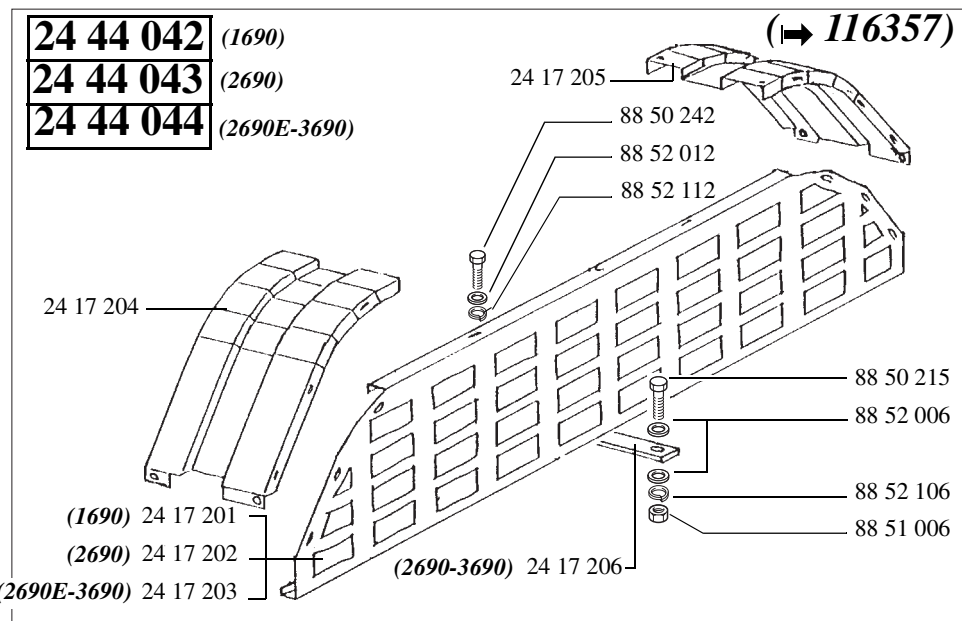
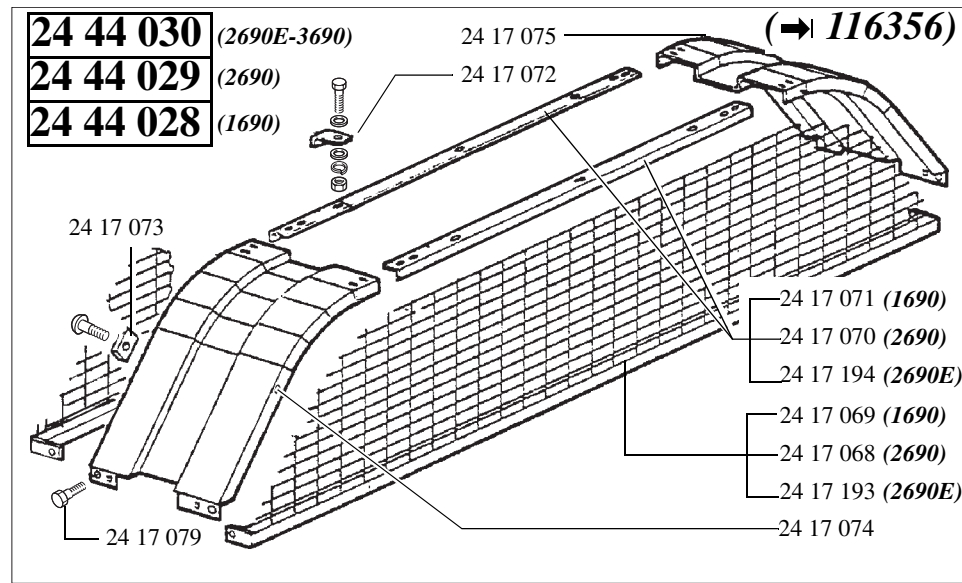
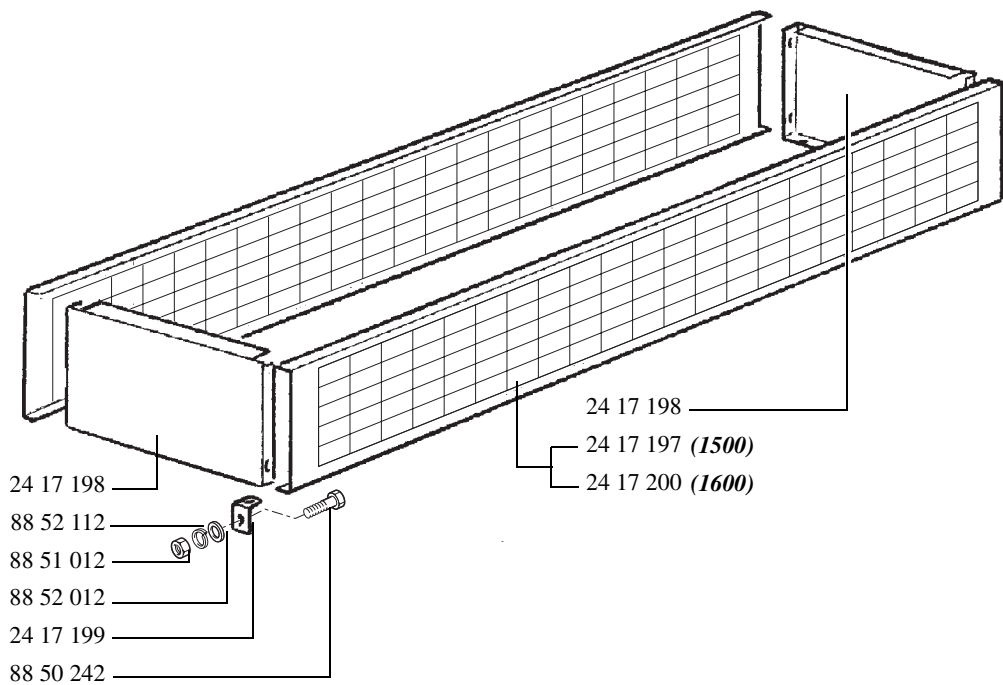

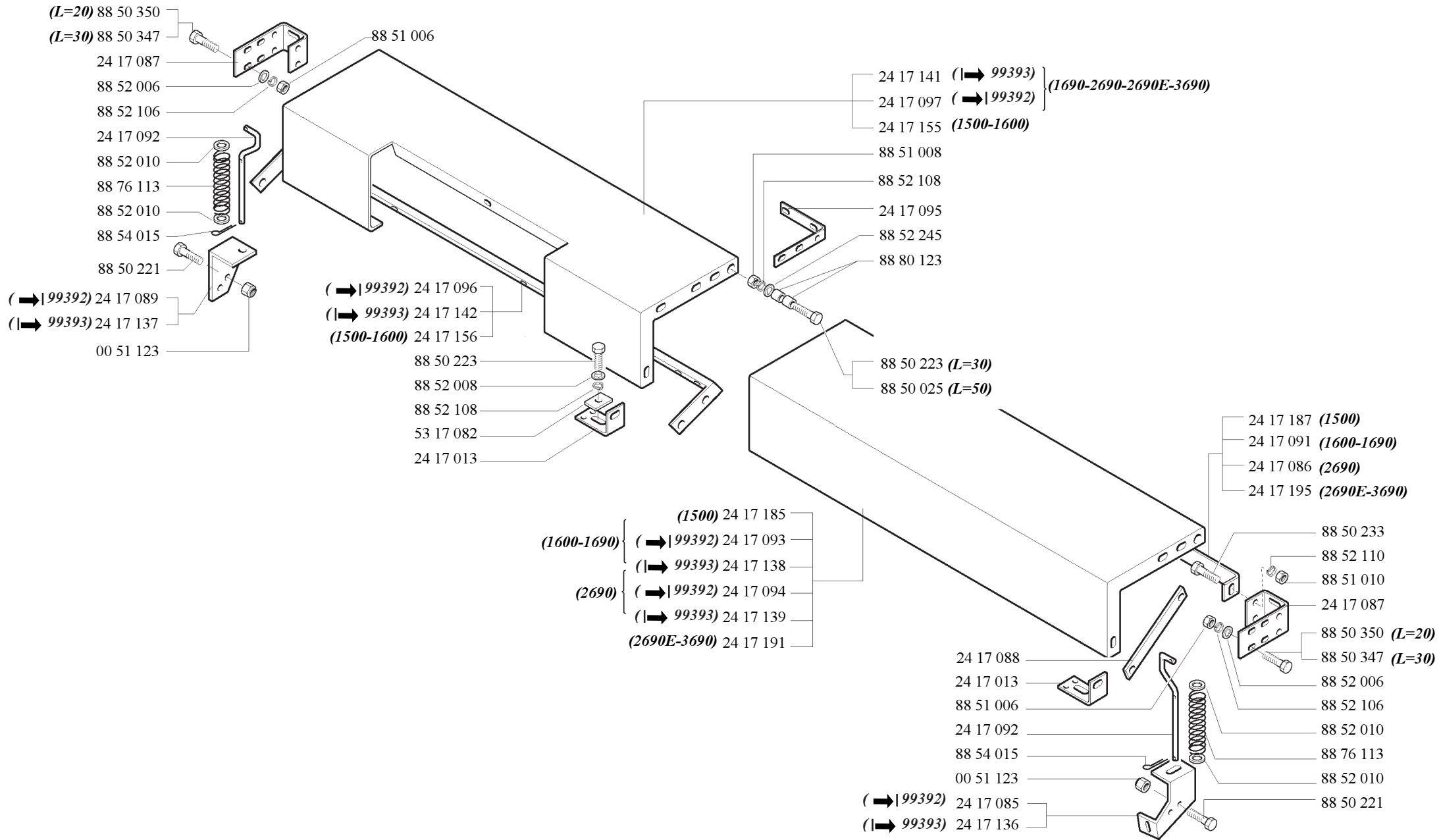

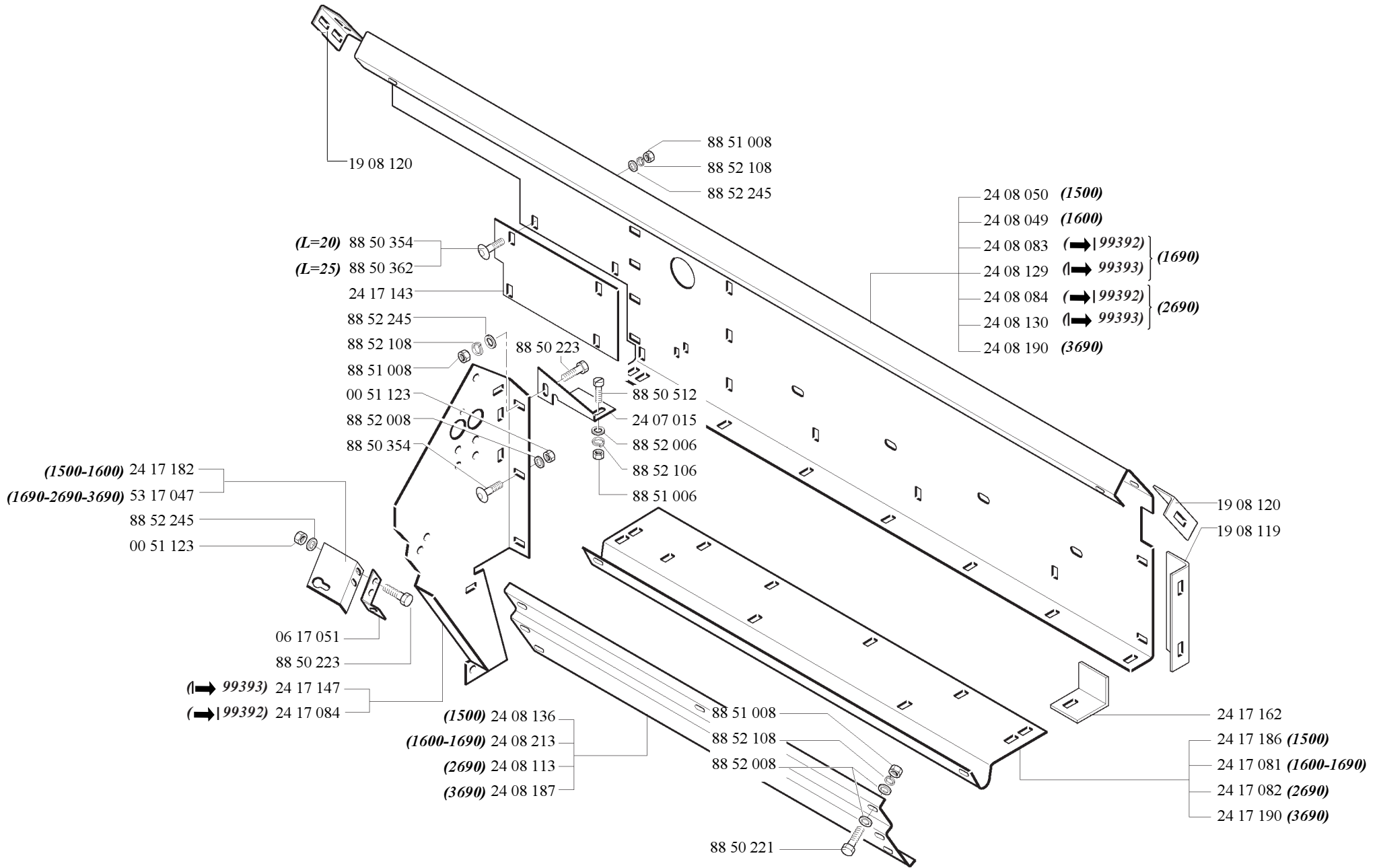

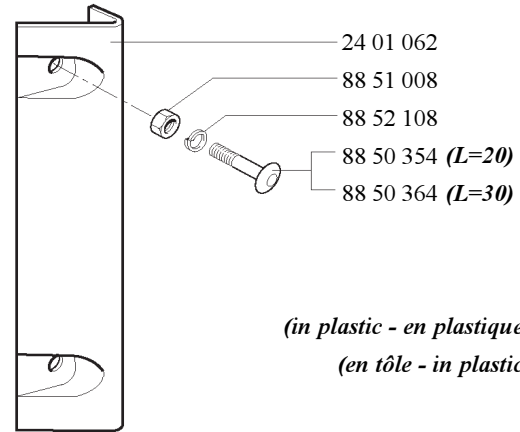
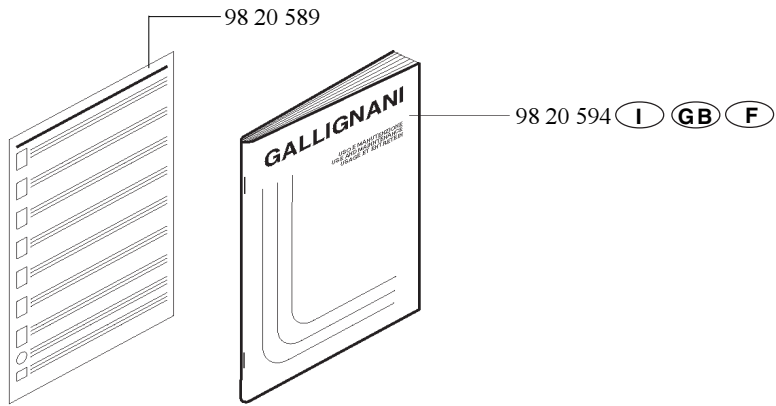

(in plastic - en plastique - in plastica) 12 01 015

(en tôle - in plastic - in lamiera) 88 82 050

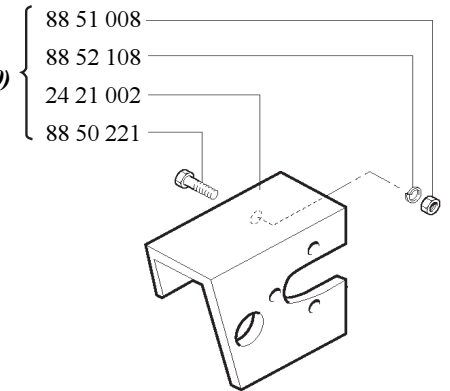
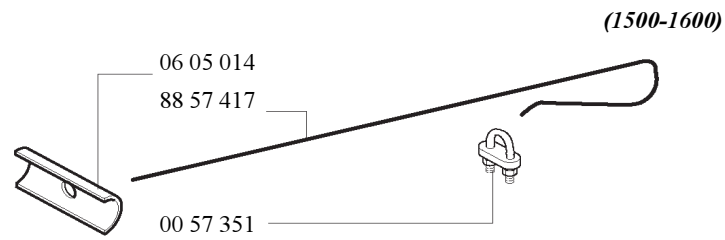
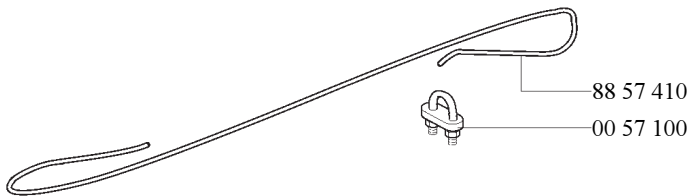
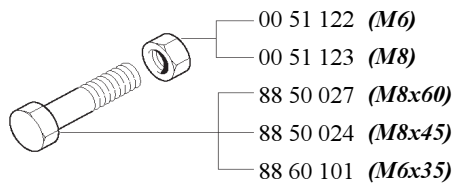
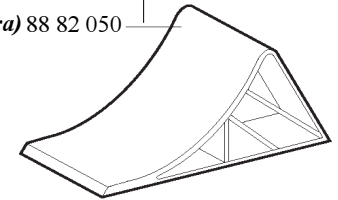

88 89 185 — GALLIGNANI

88 89 165 — GALLIGNANI

1600

88 89 168

88 89 188

88 89 158 — 1500

88 89 180 — 1600

88 89 160 — 1690

88 89 161 — 2690

88 89 157 — 3690

88 89 341 —

GALLIGNANI

88 89 182

88 89 183 — GALLIGNANI

88 89 630 — AGRAM

88 89 167 — AGRITEX

88 89 164 —

88 89 169 —

88 89 159

1600

88 89 162

1690

88 89 163

2690

88 89 198

2690.0

88 89 156

3690

GALLIGNANI

88 89 196 (1690-2690-3690)

88 89 197 (1500-1600)

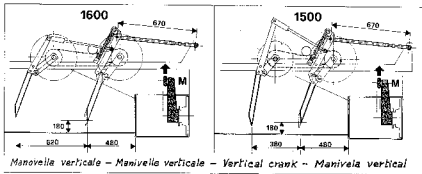

88 89 166

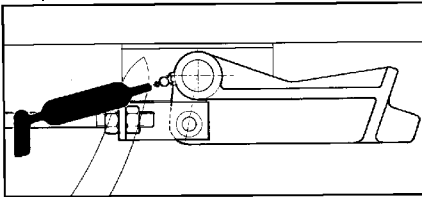

88 89 059

AVVERTENZE IMPORTANTI	REMARQUES IMPORTANTES	IMPORTANT ADVICES	ADVERTENCIAS IMPORTANTES
● PRIMA DI ESPETTUARE QUALSIASI OPERAZIONE SULLA MACCHINA, FERMARE LA PRESA DI FORZA ED IL MOTORE DEL TRATTORE.	● AVANT DE PROCÉDER À UN RÉGLAGE OU À UNE OPÉRATION, ARRÊTER LA PRESSE DE FORCE ET LE MOTEUR DU TRACTEUR.	● BEFORE WORKING ON THE MACHINE, DISCONNECT THE P.T.O. SHAFT AND STOP THE TRACTOR ENGINE.	● ANTES DE EFECTUAR CUALQUIERA OPERACIÓN, DESCONECTAR LA TOMA DE FUERZA Y EL MOTOR DE TRACTOR.
● CONTROLLARE CHE TUTTE LE PROTEZIONI SIANO MONTATE.	● PRÉVENIR TOUTES LES GARDES ÊTRE EN PLACE.	● ALL GUARDS DEMAND TO BE FITTED.	● TODOS LOS DISPOSITIVOS DE PROTECCIÓN DEBEN ENCONTRARSE MONTADOS.
● NON AVVICINARSI ALLA MACCHINA DURANTE IL LAVORO.	● NE PAS S'APPROCHER DE LA MACHINE PENDANT LE TRAVAIL.	● KEEP AWAY WHILE THE MACHINE IS WORKING.	● MANTENERSE A DISTANCIA DE LA MÁQUINA DURANTE EL TRABAJO.

88 89 990

88 89 408

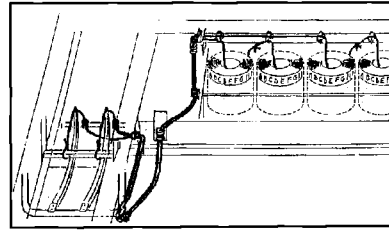
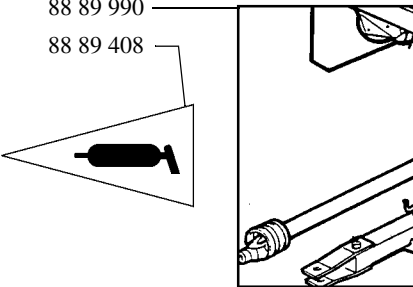

⚠ CIRCOLA LUNA DI SICUREZZA 1600

■ Al smontare dell'art. 106 del colico della stivola (011.289.1950), le molle del sistema operativo di trazione possono non essere munite di dispositivo di frenatura quando il loro peso complessivo non è superiore a quello riconosciuto trattabile dal trattore per questo tipo di macchina oppure a quello del trattore (esemp. 472 del regol. del n. 3).

■ Al smontare del colico della stivola le macchine agricole operatrici trattate sono assai soggette ad embrogliare e pertanto non hanno l'obbligo di essere munite della cart. di circolazione.

88 89 989

88 89 253

88 89 068

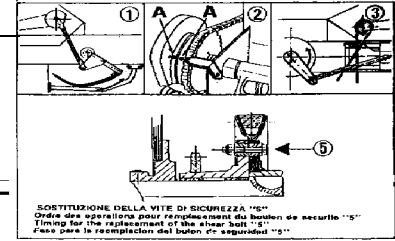

88 89 191

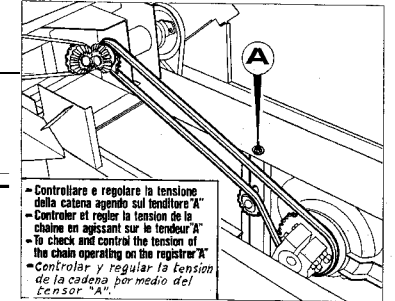

88 89 177

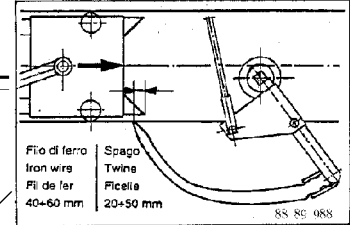
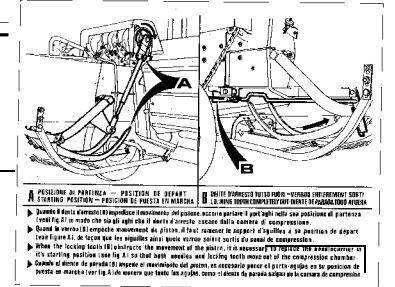

88 89 988

88 89 082

88 89 199

2.5 bar

Max 610 RPM

Max 25 Km/h

88 89 864

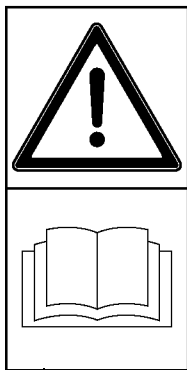

88 89 282



88 89 391



88 89 286

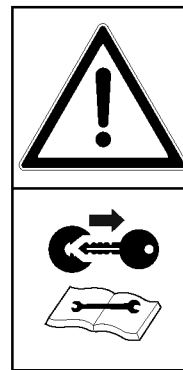

88 89 283



88 89 390

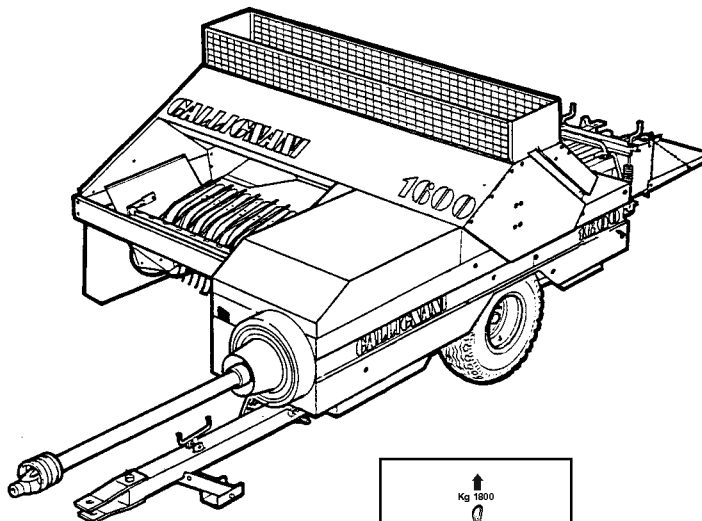

88 89 377

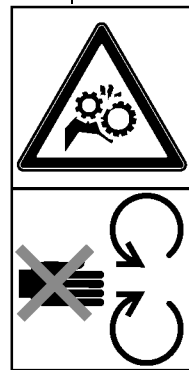
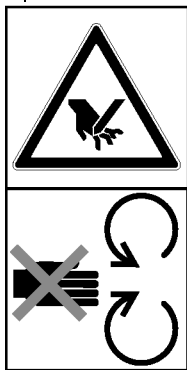

88 89 386

88 89 285



88 89 394

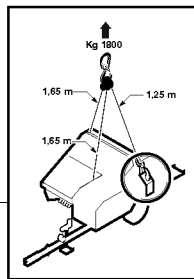

88 89 B77

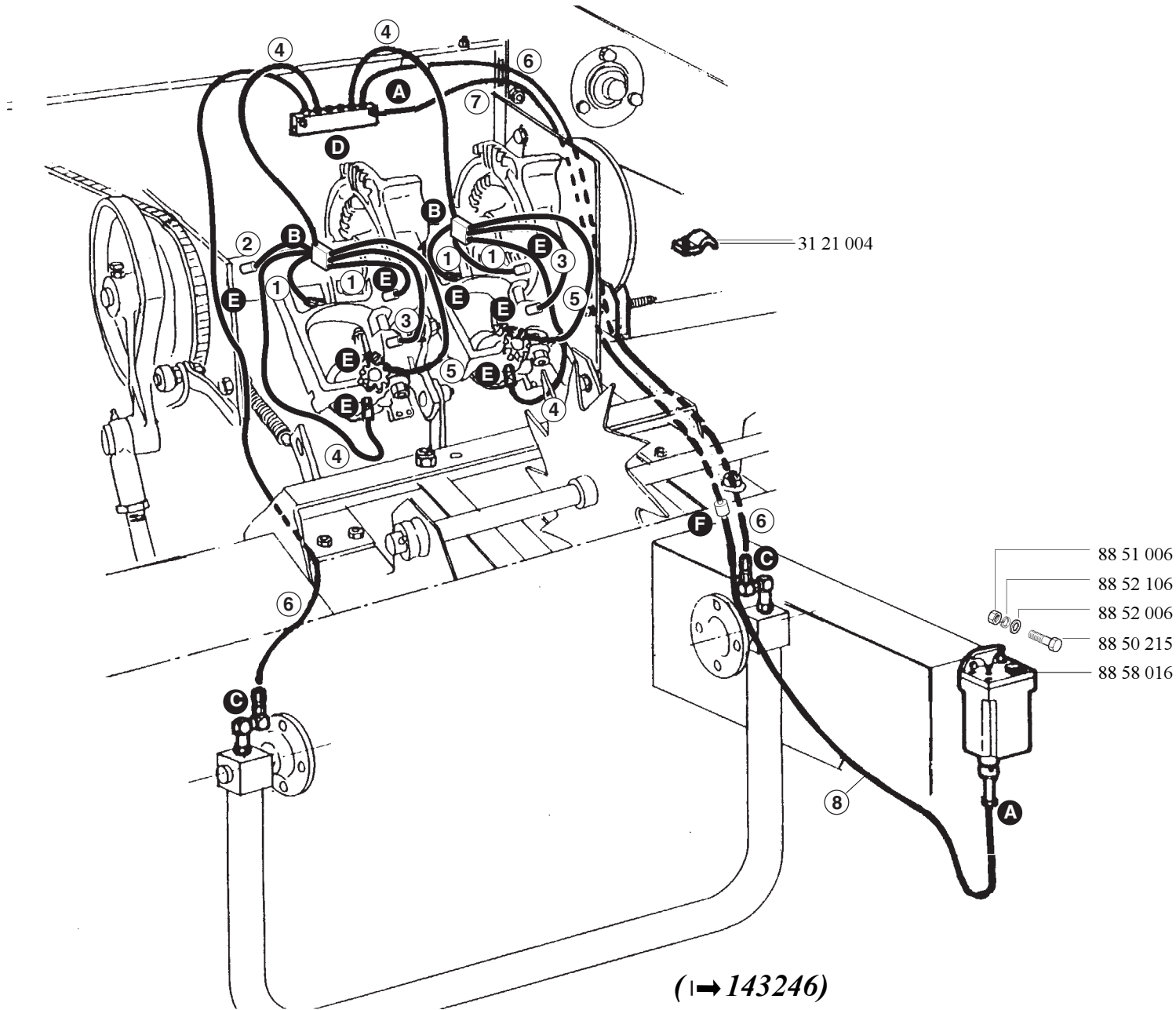

(1 → 143246)

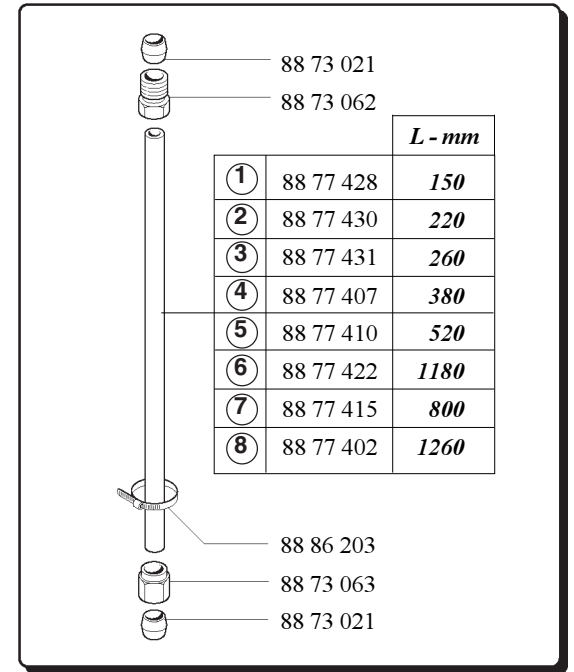

S10 ↗
 ↙ S11
06 46 101

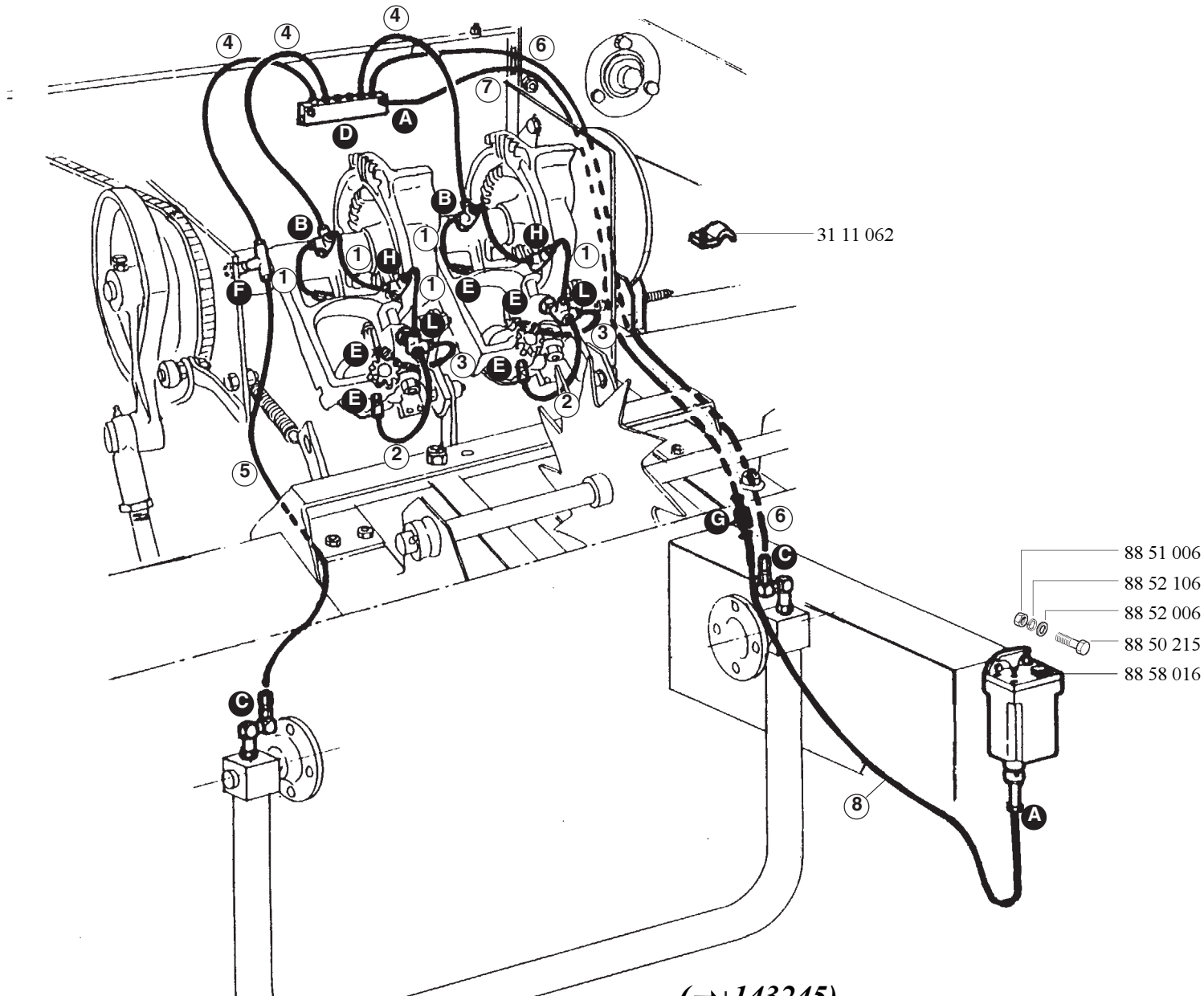

(→143245)

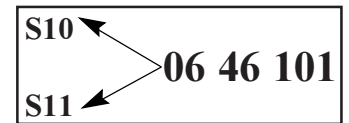
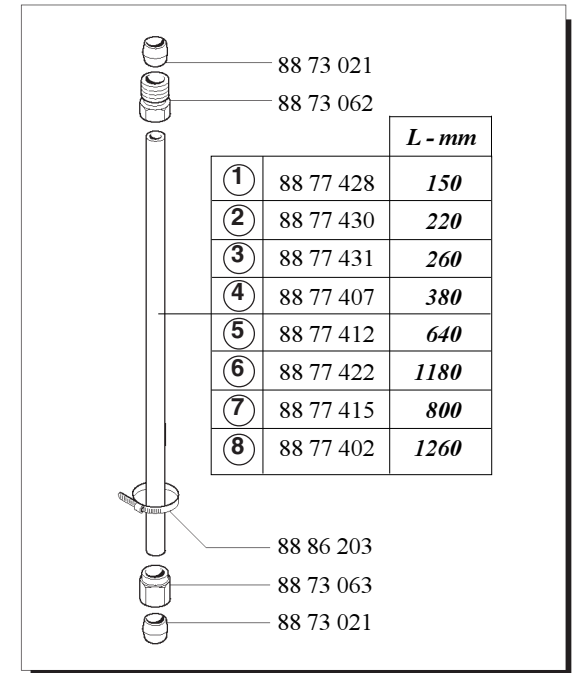

A

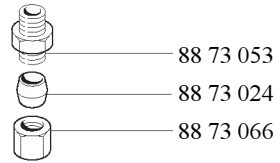

88 73 053

88 73 024

88 73 066

B

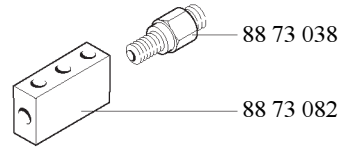

88 73 038

88 73 082

C

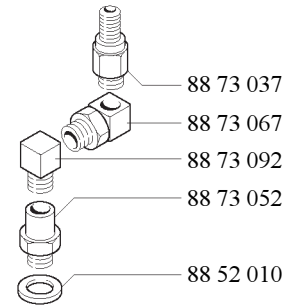

88 73 037

88 73 067

88 73 092

88 73 052

88 52 010

D

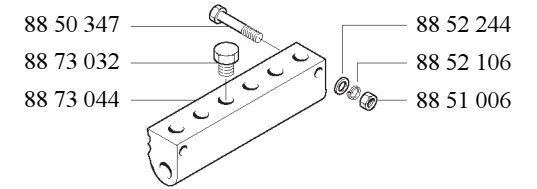

88 50 347

88 73 032

88 73 044

88 52 244

88 52 106

88 51 006

E



88 73 037

F

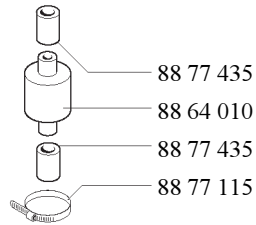

88 77 435

88 64 010

88 77 435

88 77 115

(1 → 143246)

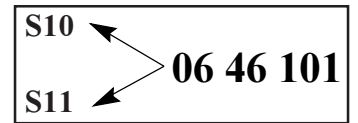

A

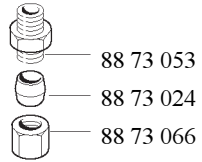

B

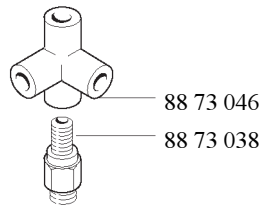

C

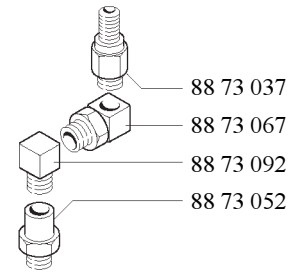

D

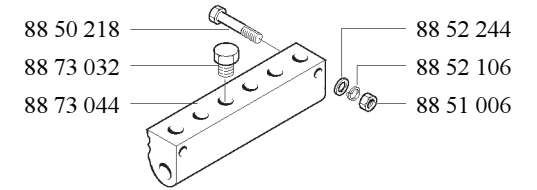

E

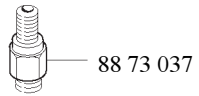

F

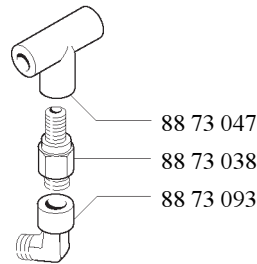

G

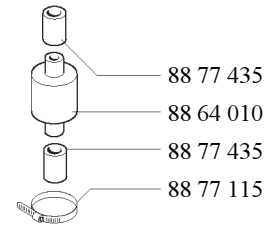

H

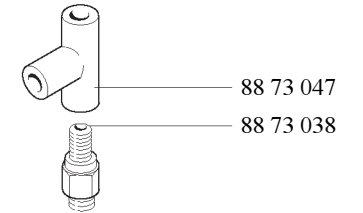

L

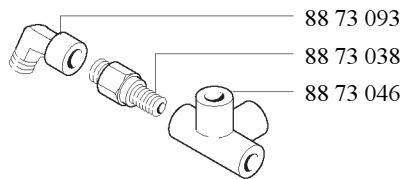

(→143245)

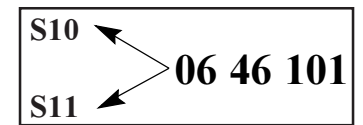

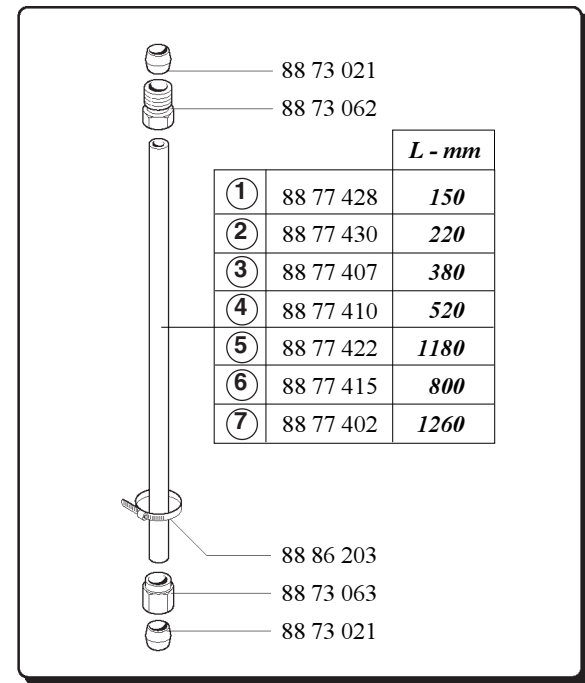
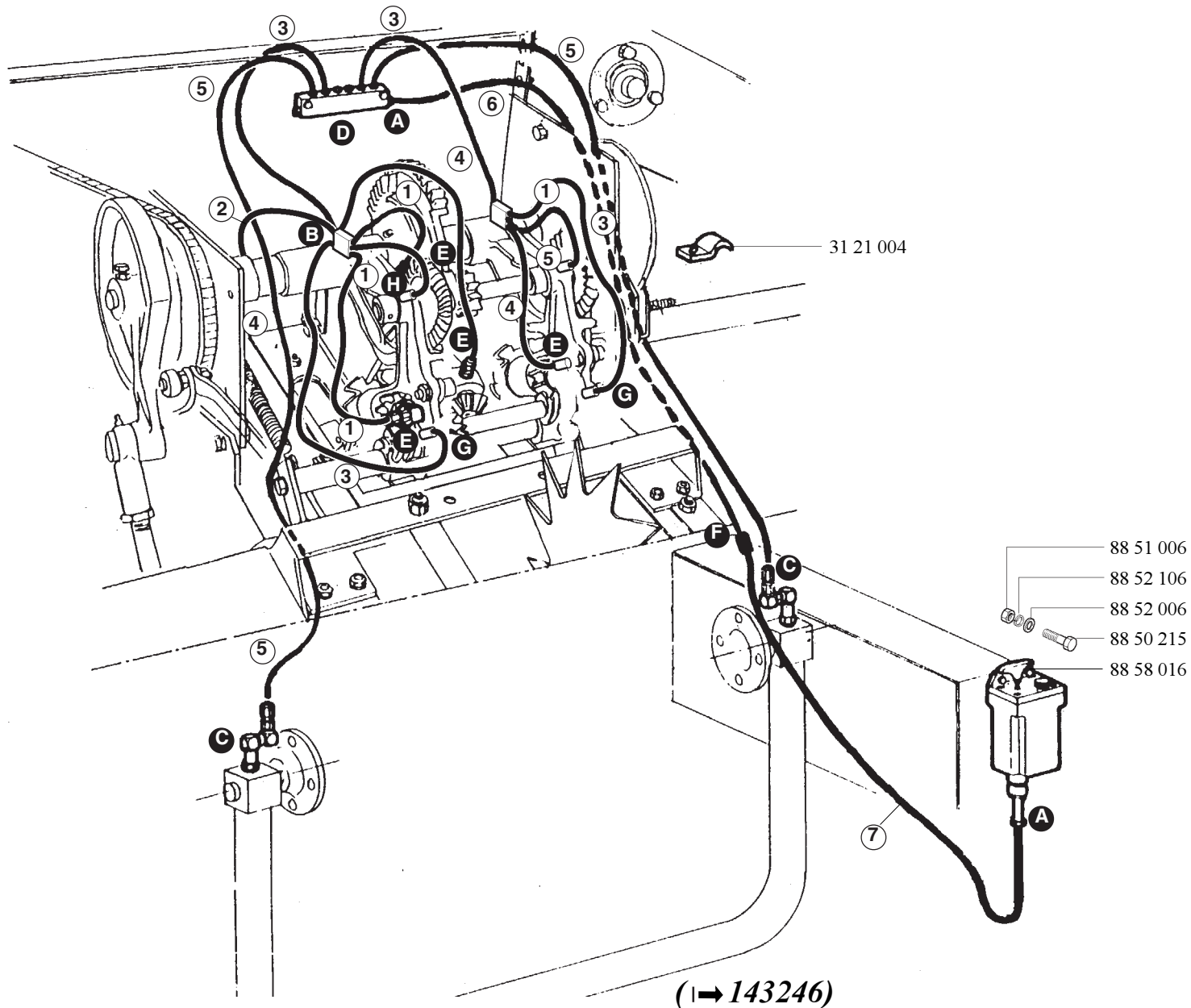

(1 → 143246)

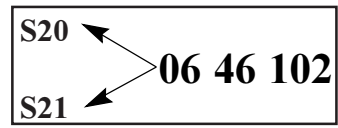

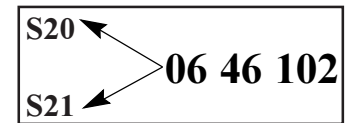
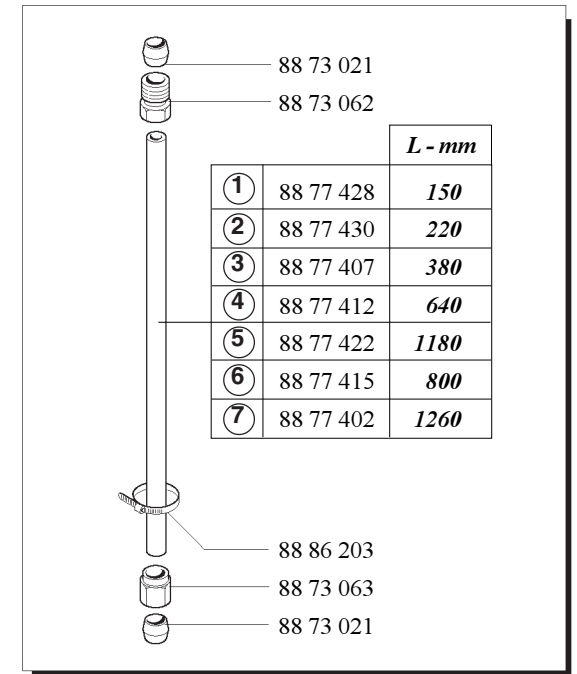
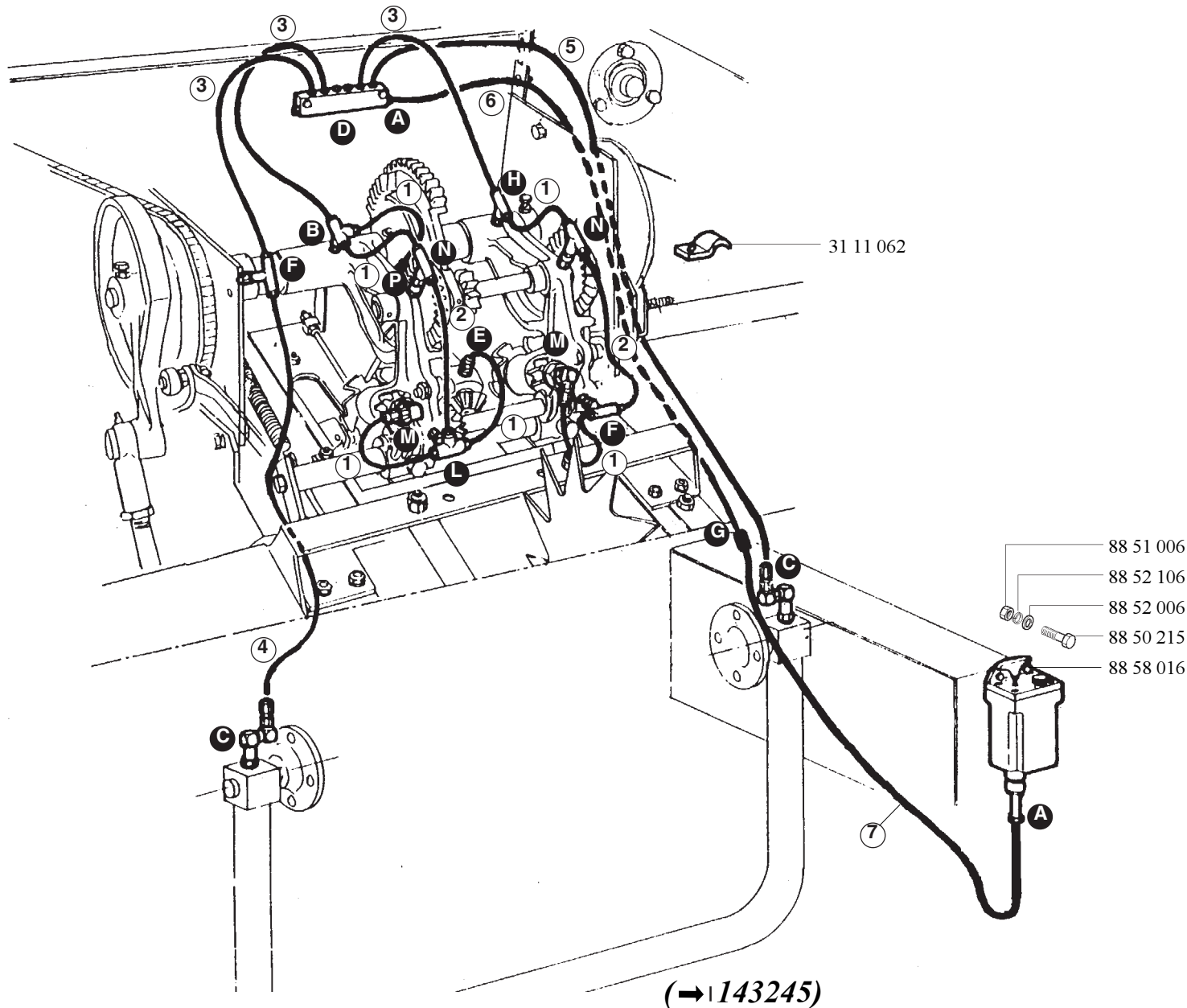

A

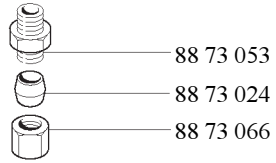

B

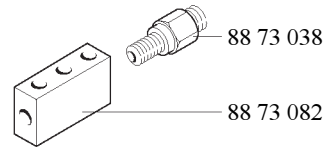

S20
S21
06 46 102

C

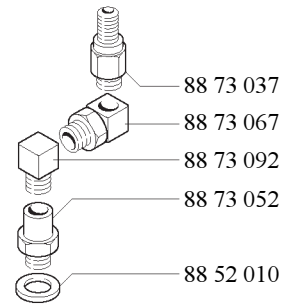

D

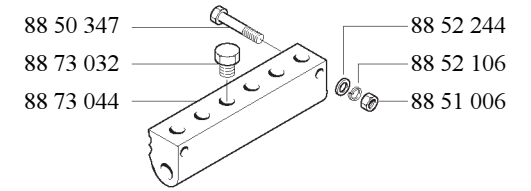

E

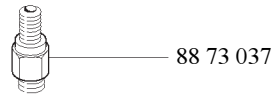

F

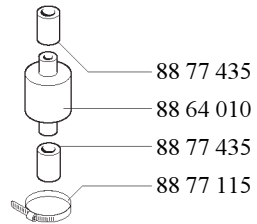

G

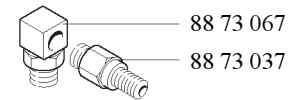

H

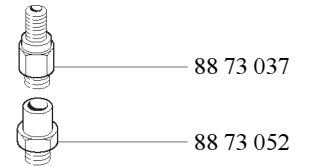

(1 → 143246)

A

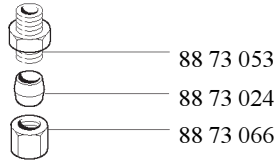

B

S20
S21

06 46 102

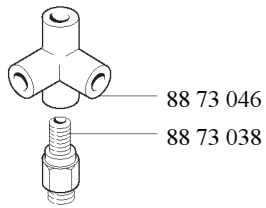

C

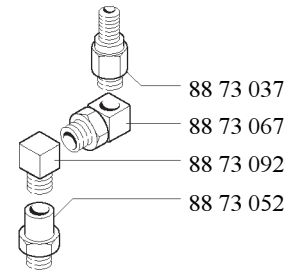

D

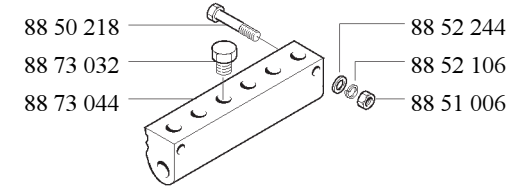

E

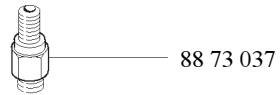

F

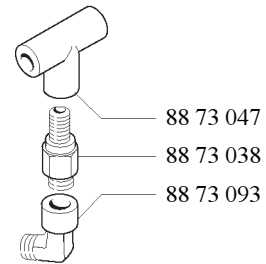

G

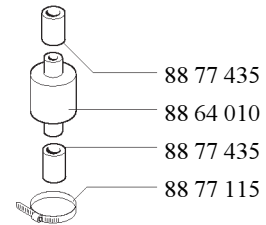

H

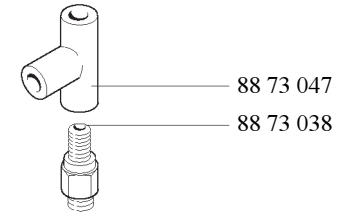

L

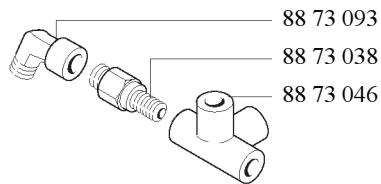

M

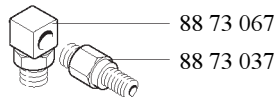

N

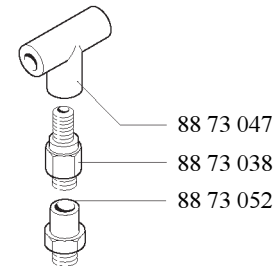

P

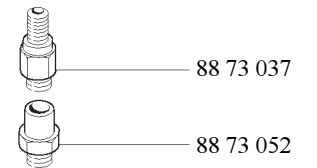

(→143245)

06 46 106

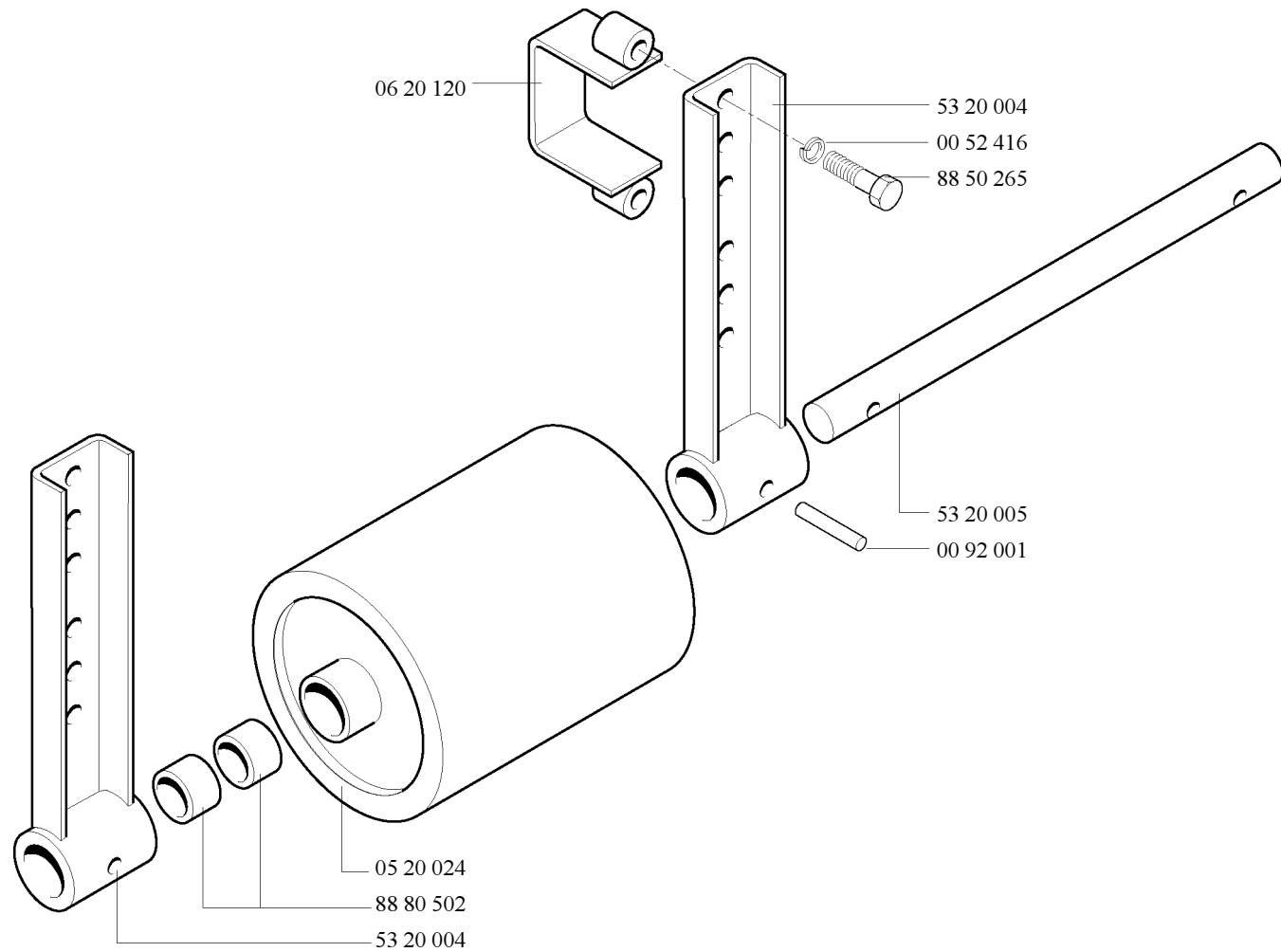

06 46 110

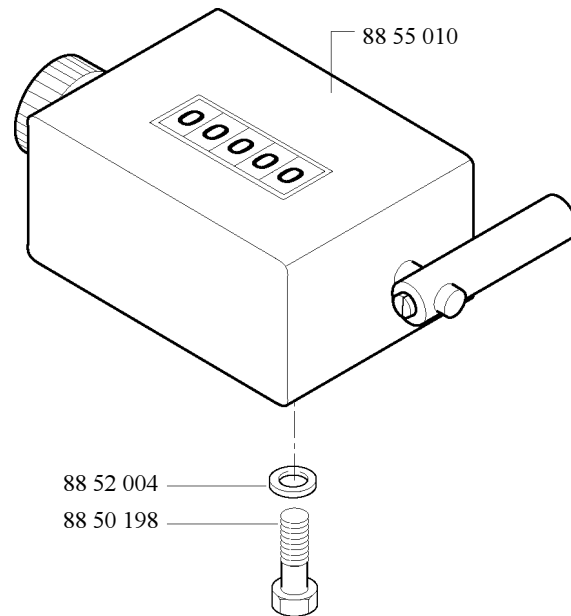

12 46 001

10.0/80-12
31 44 015
00 75 207
00 75 110
88 75 349

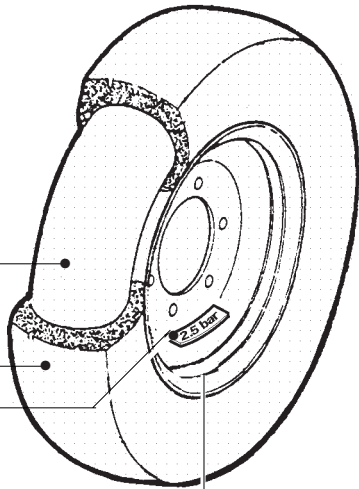

88 89 864

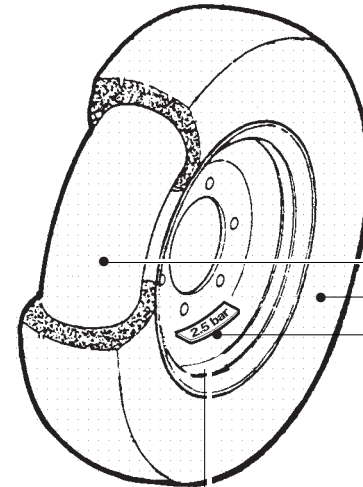

7.00-12
45 44 008
00 75 208
00 75 123
88 75 308

88 89 864

(→ 142279)

15 46 002

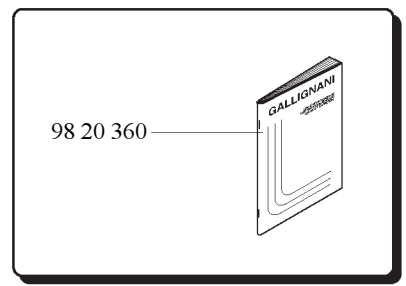
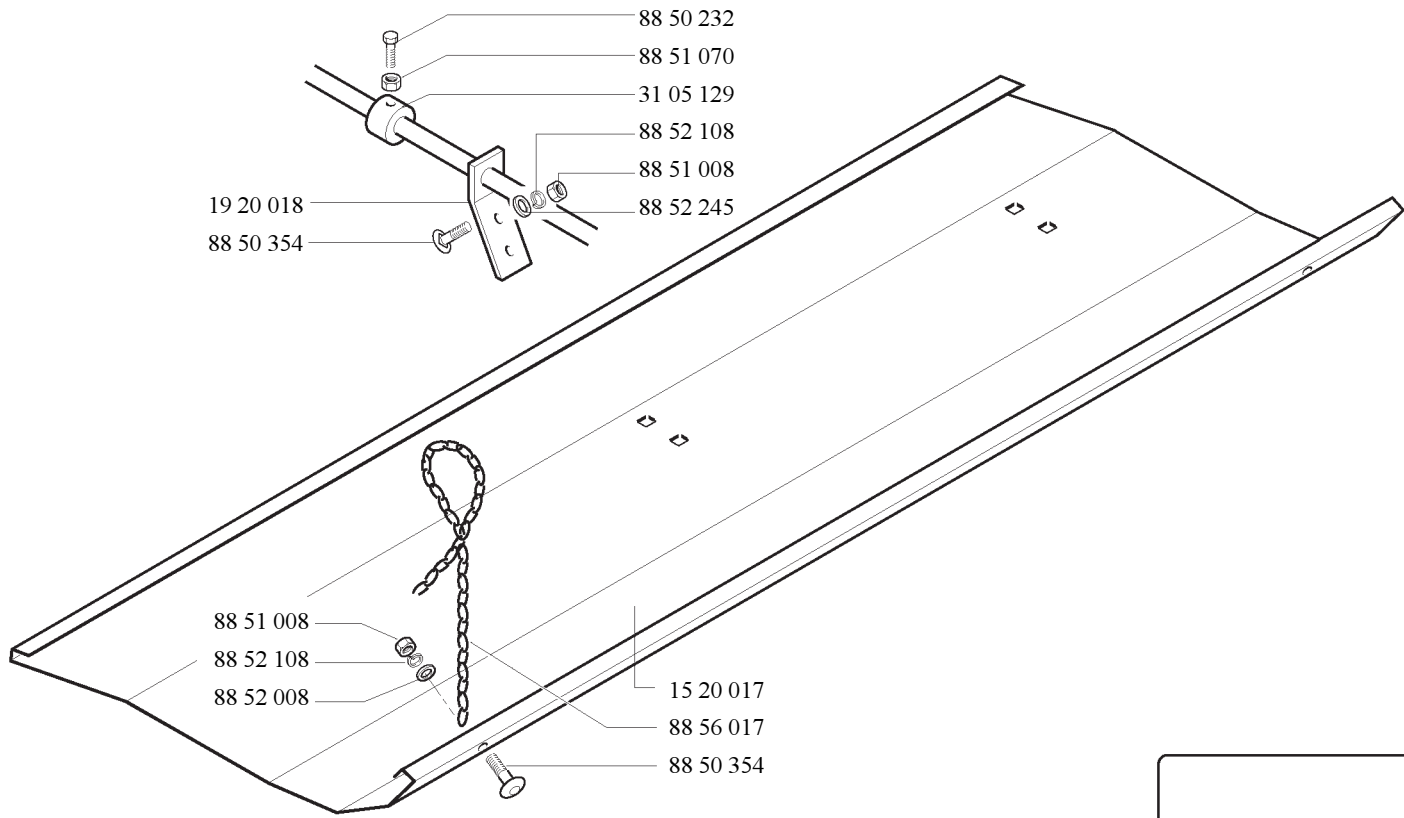

24 46 014

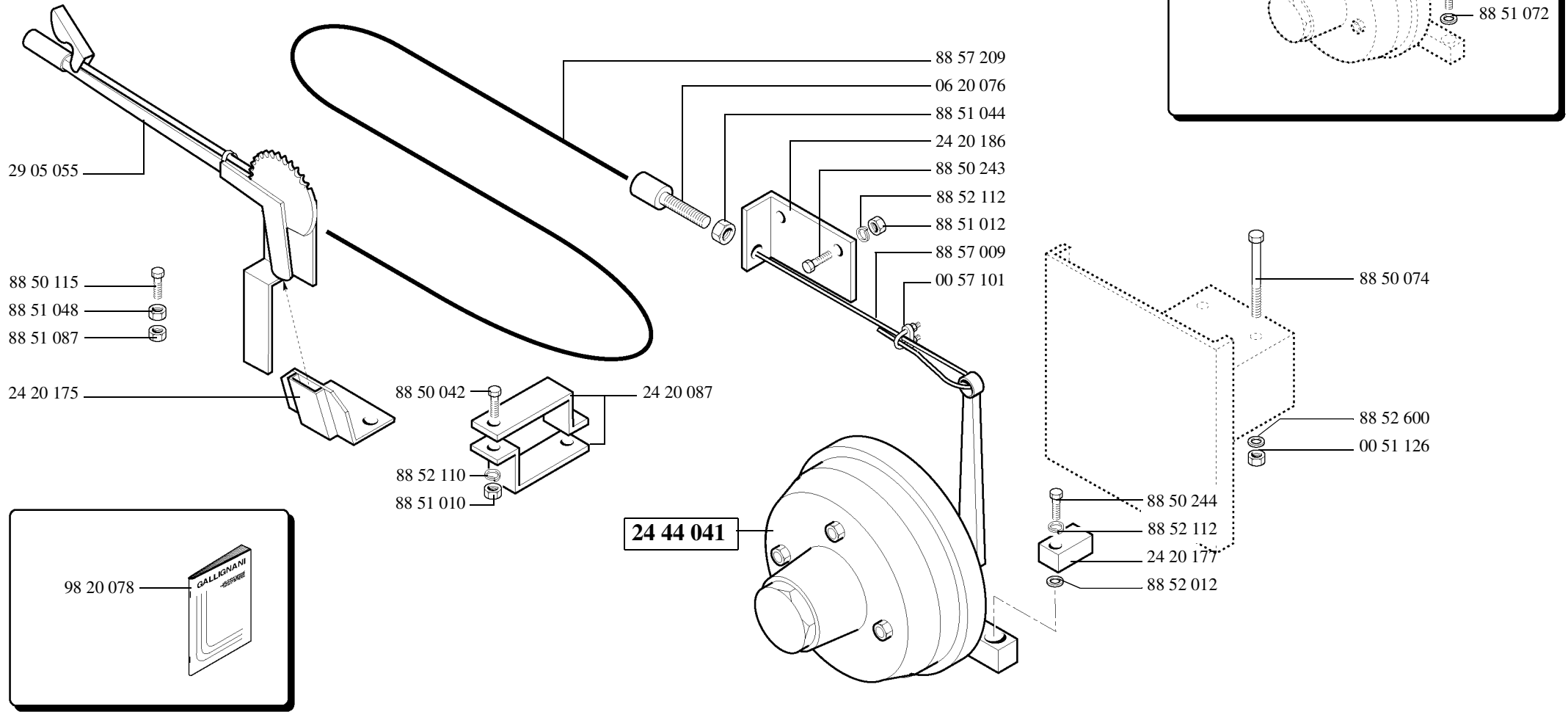

24 46 031

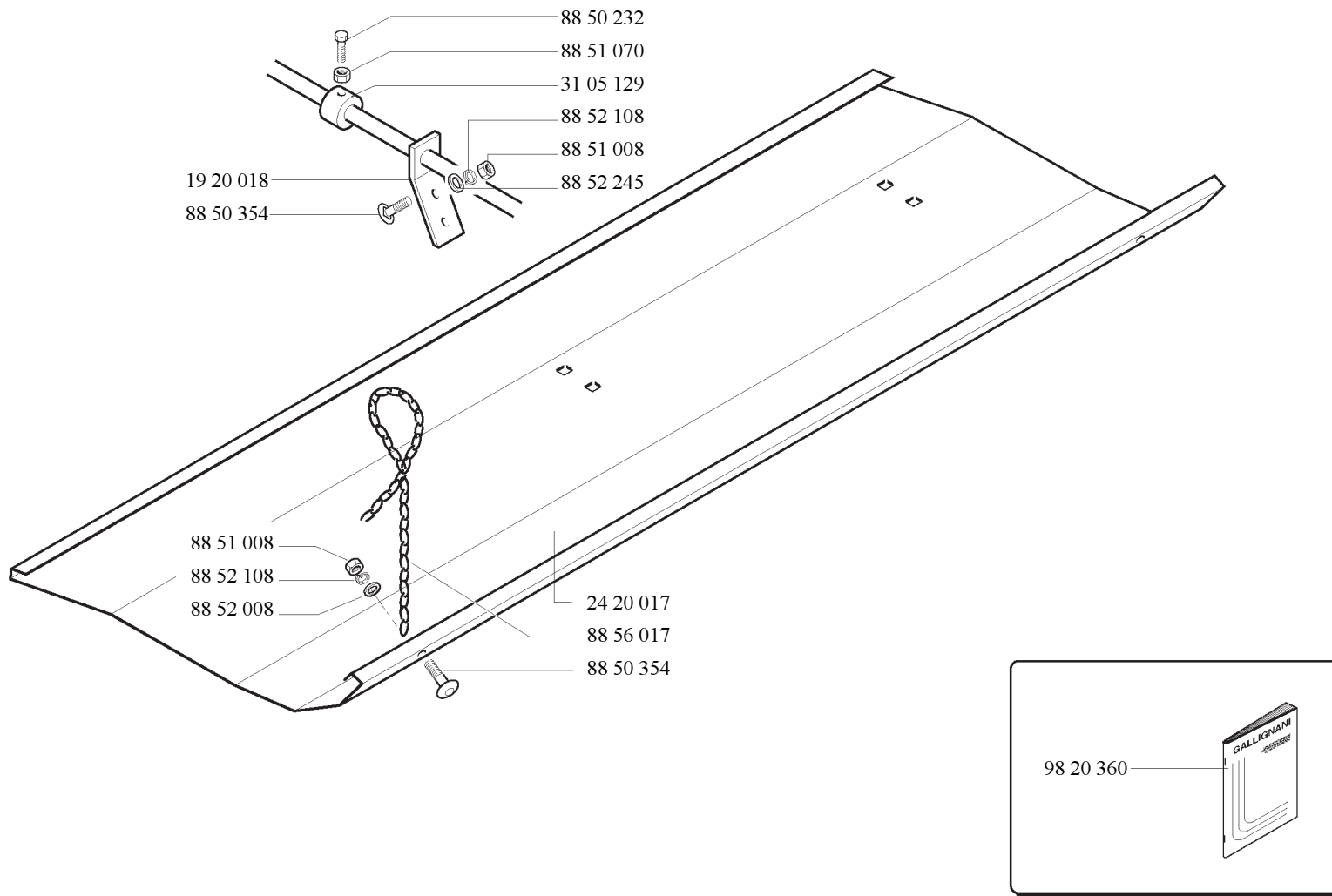

24 46 032

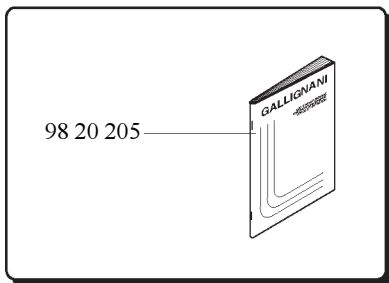
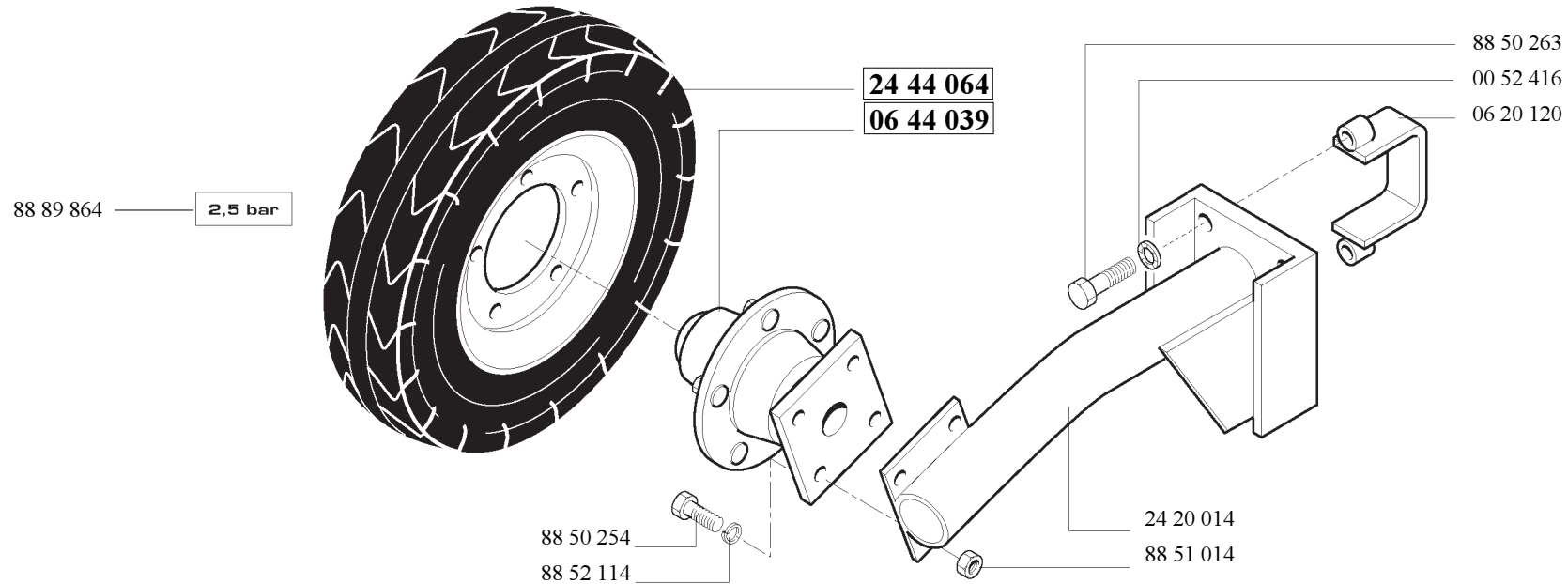

(I → 93142)

24 46 032

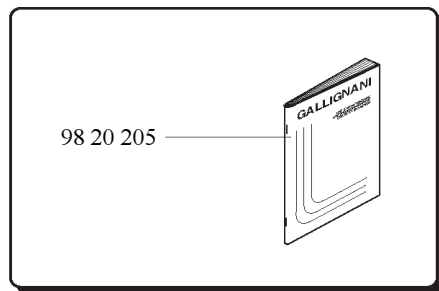
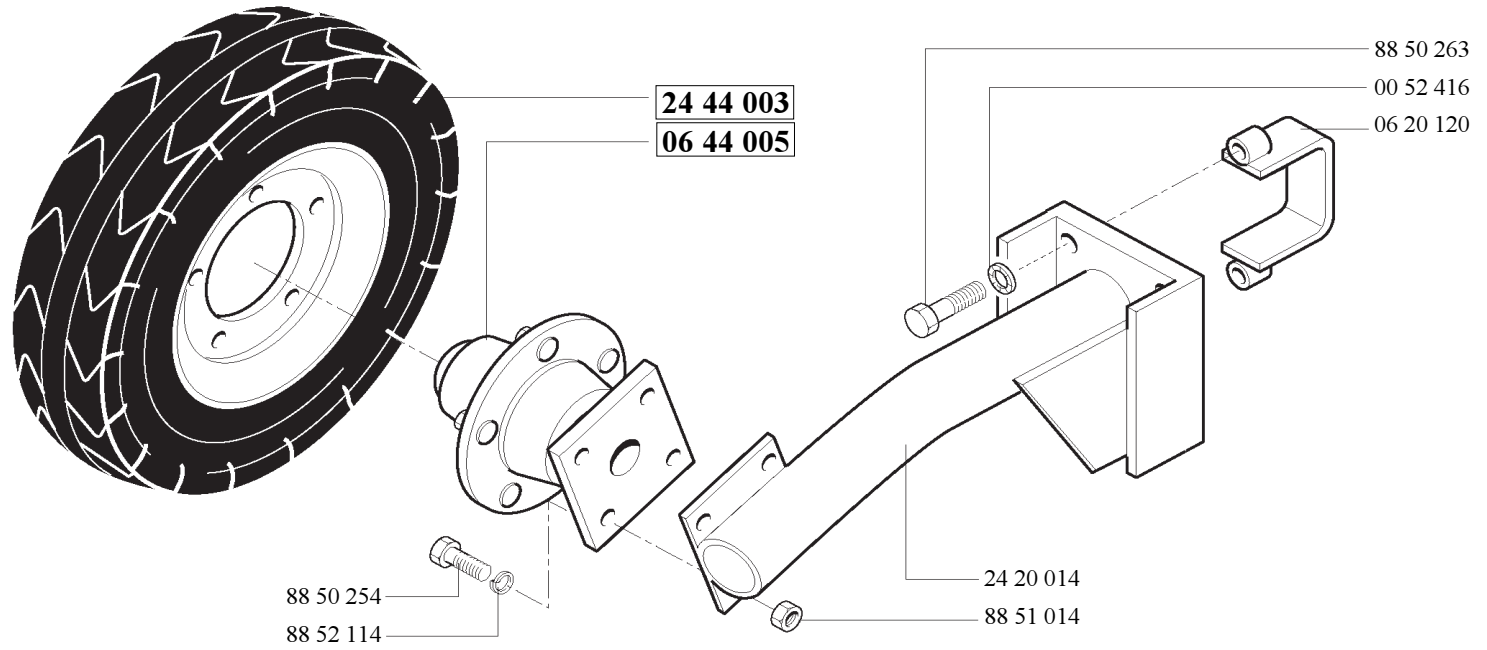

(→ 93141)

24 46 034

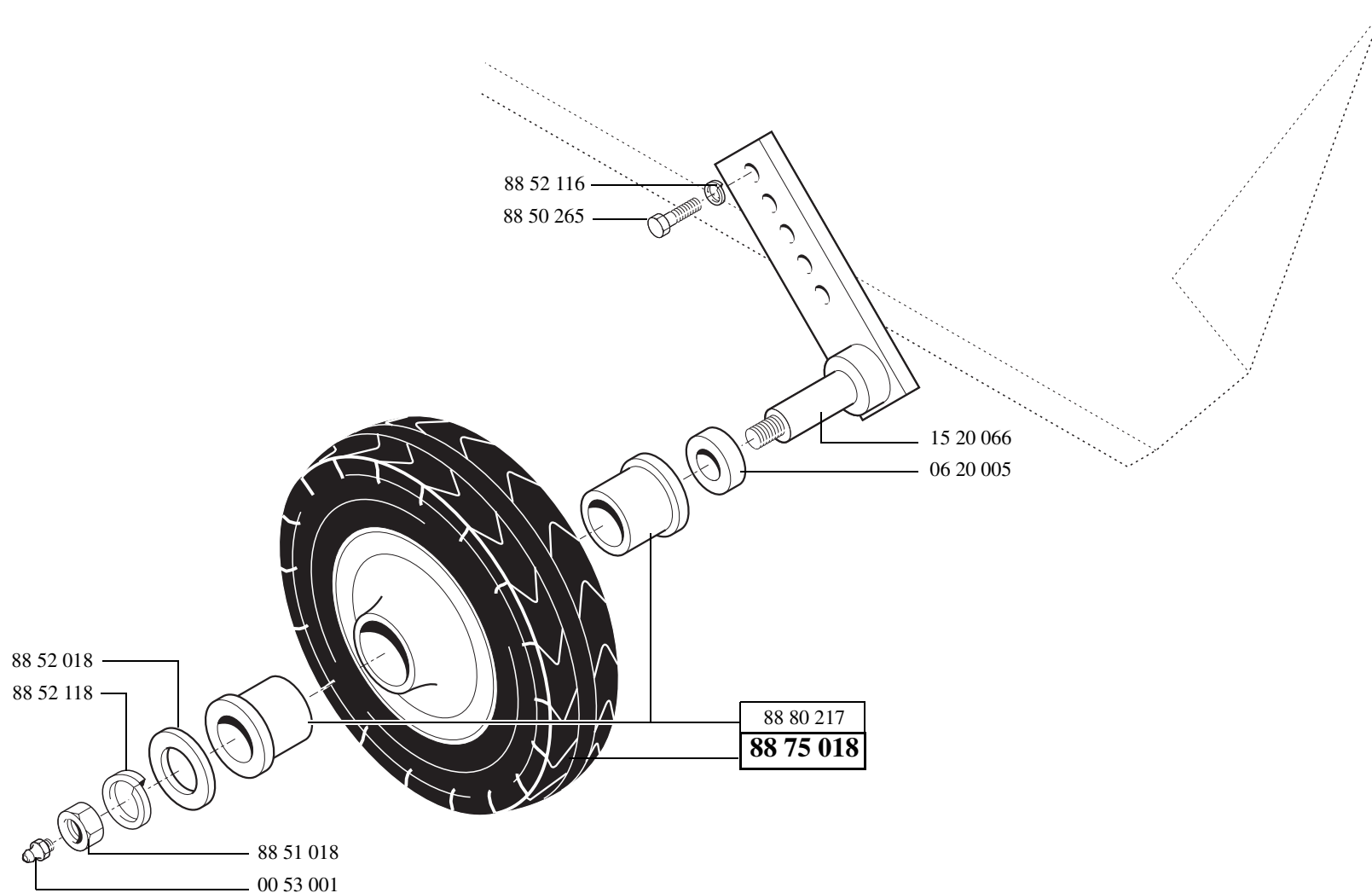

24 46 035

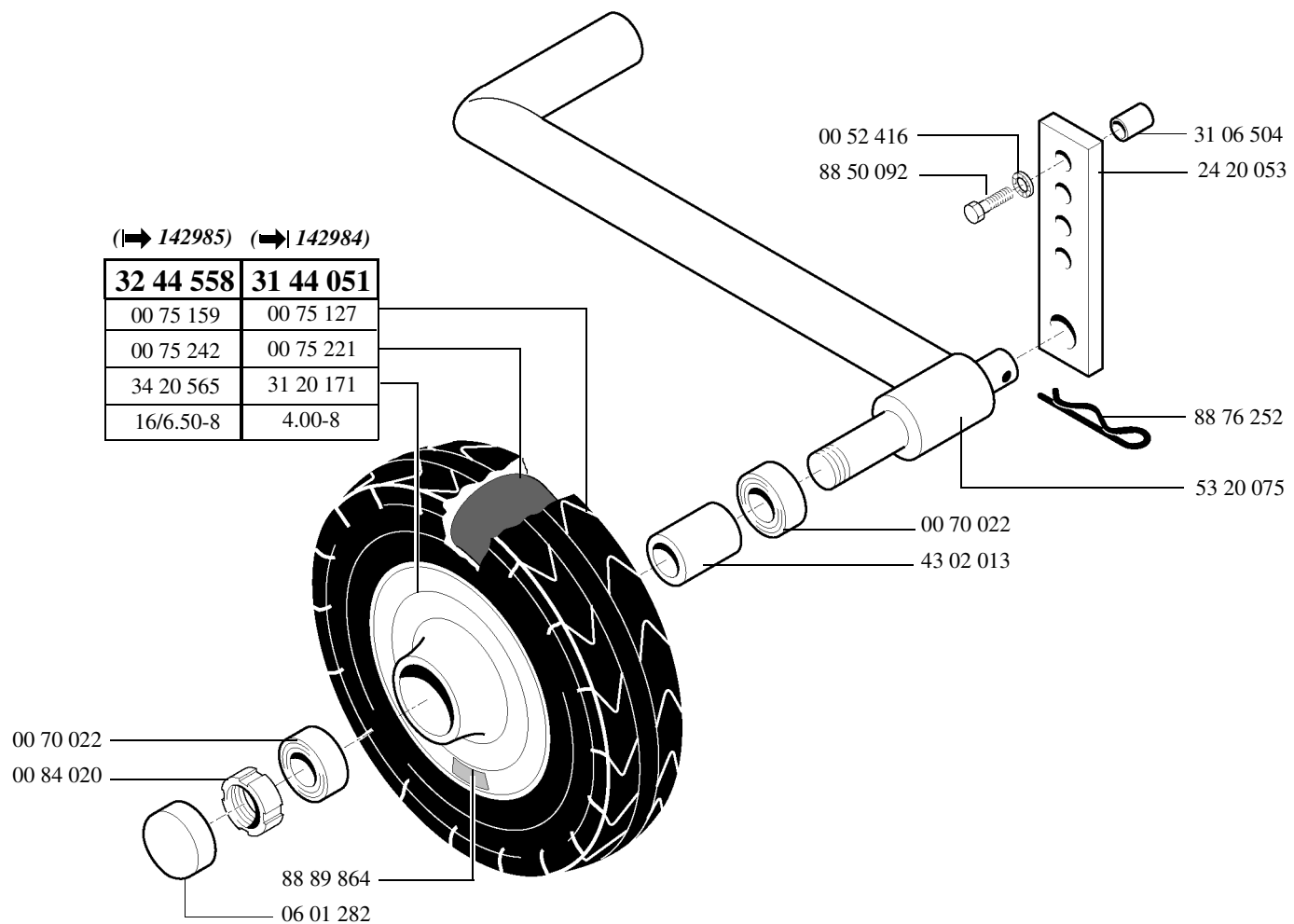

24 46 036

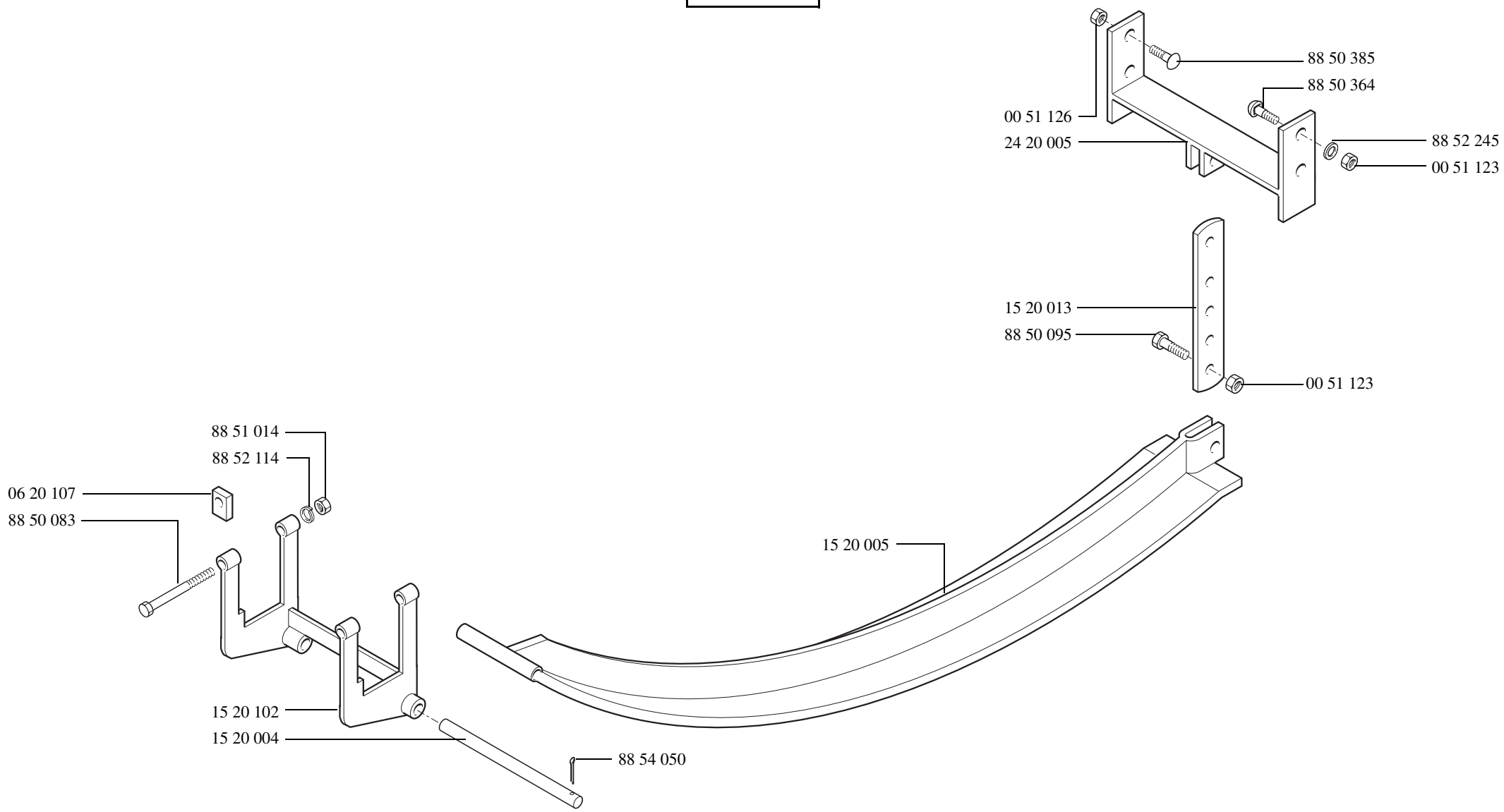

24 46 039

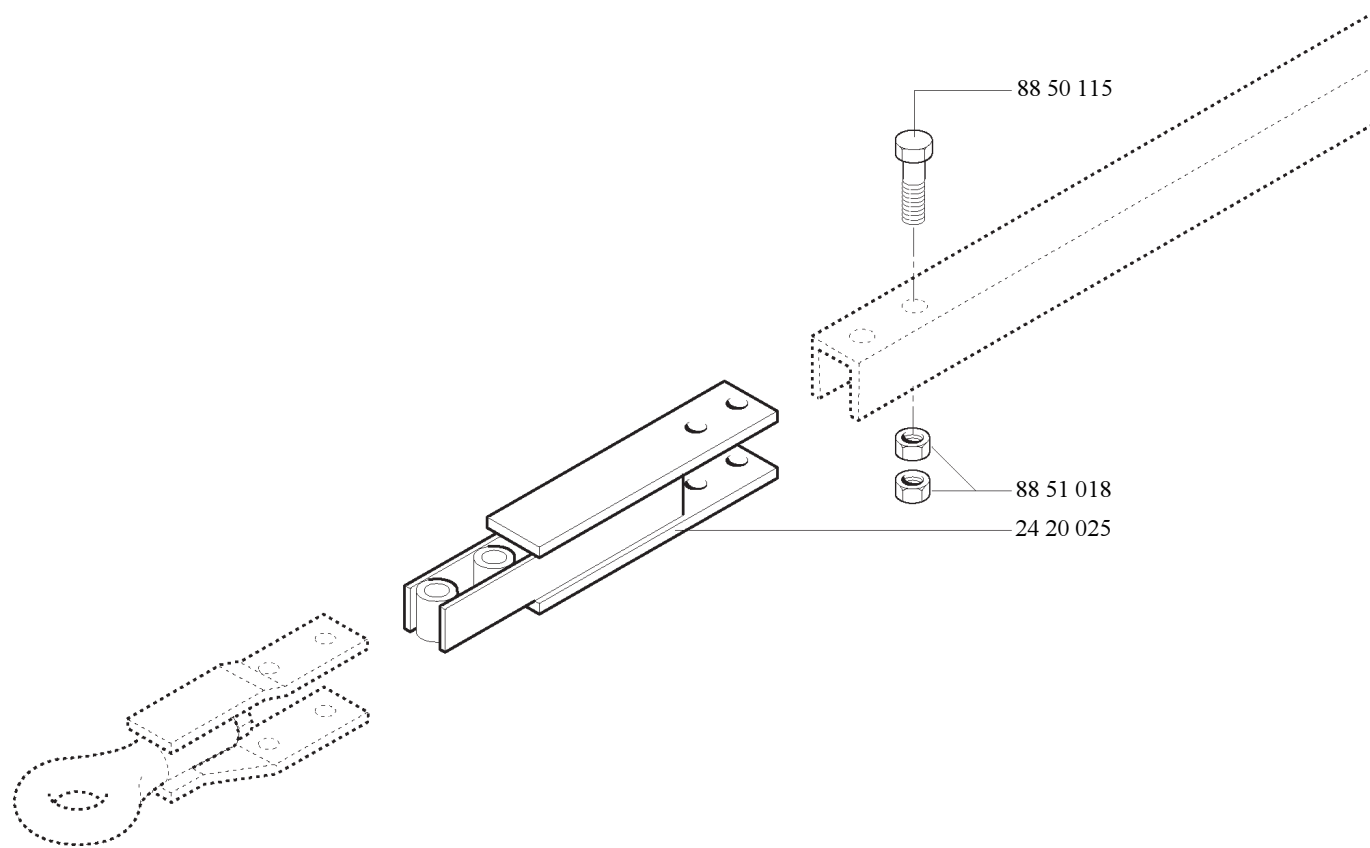

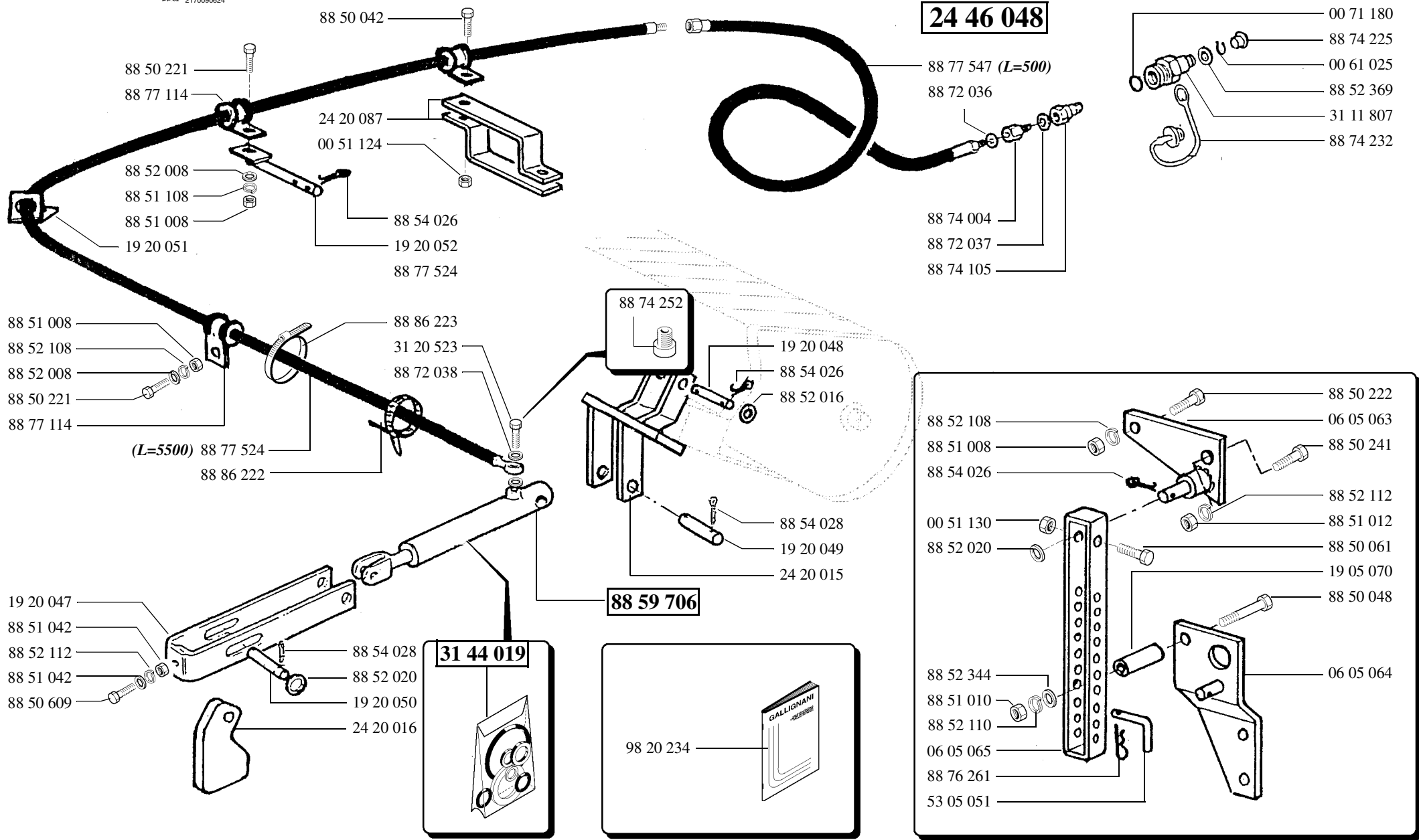

24 46 049

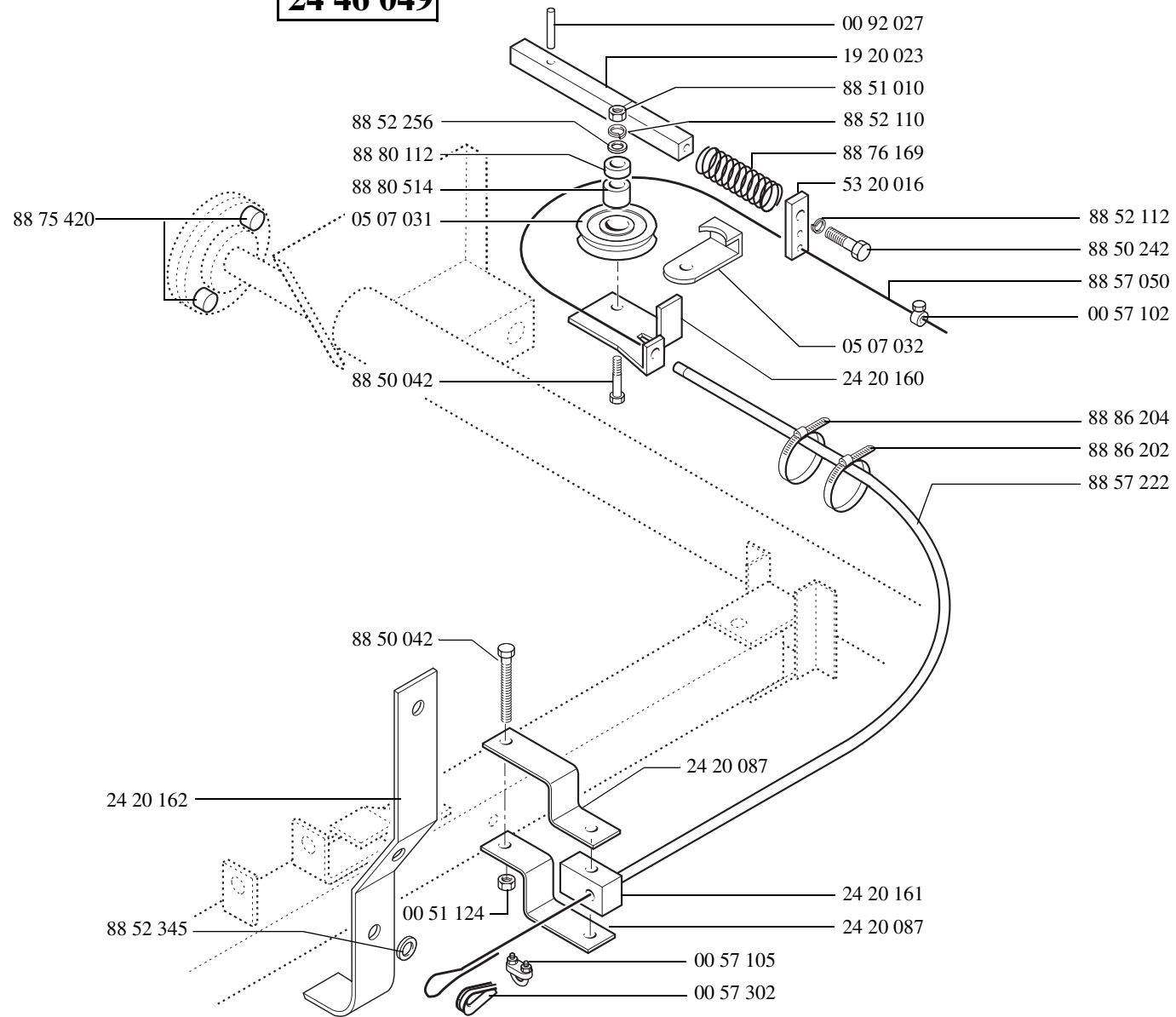

24 46 052

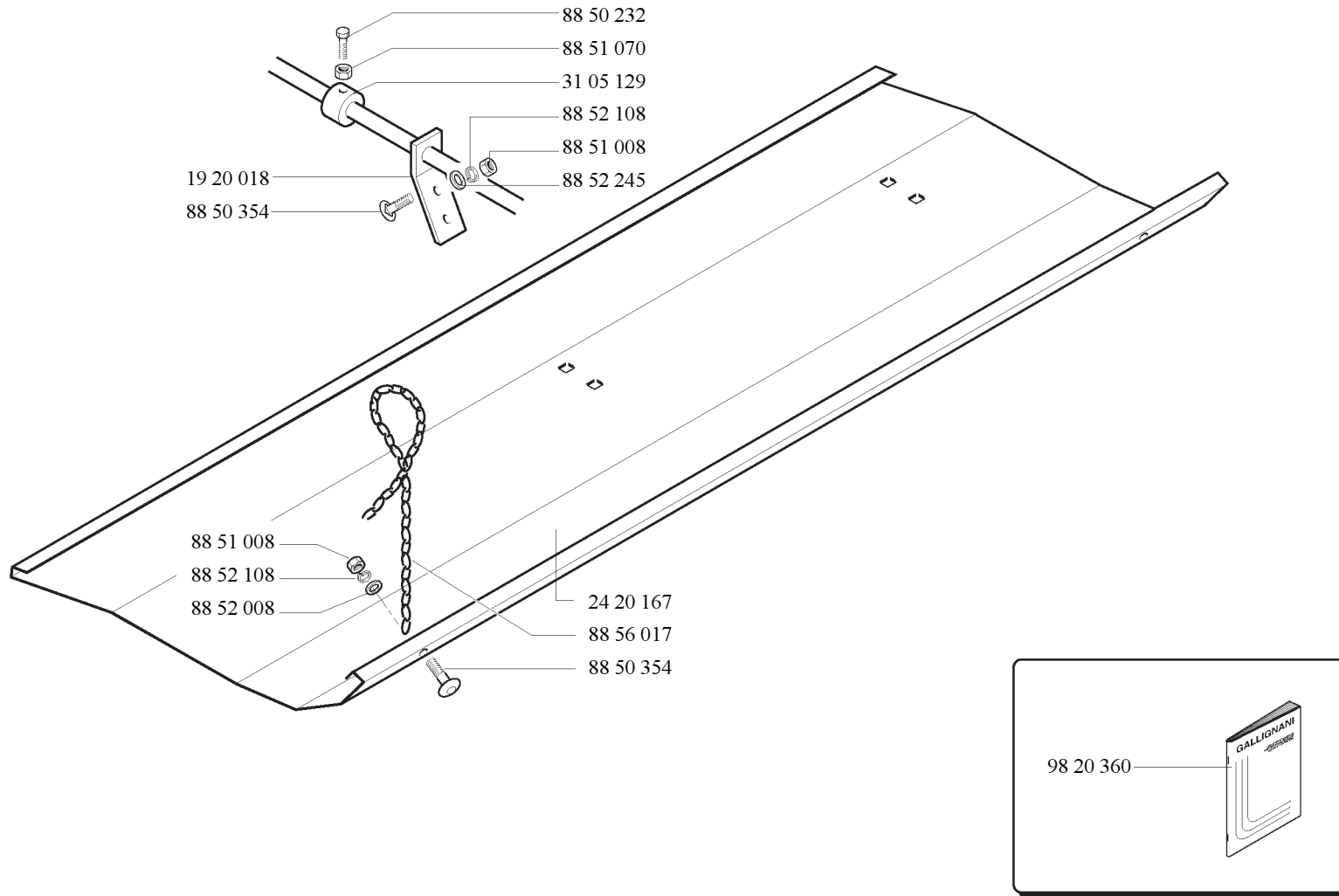

24 46 053

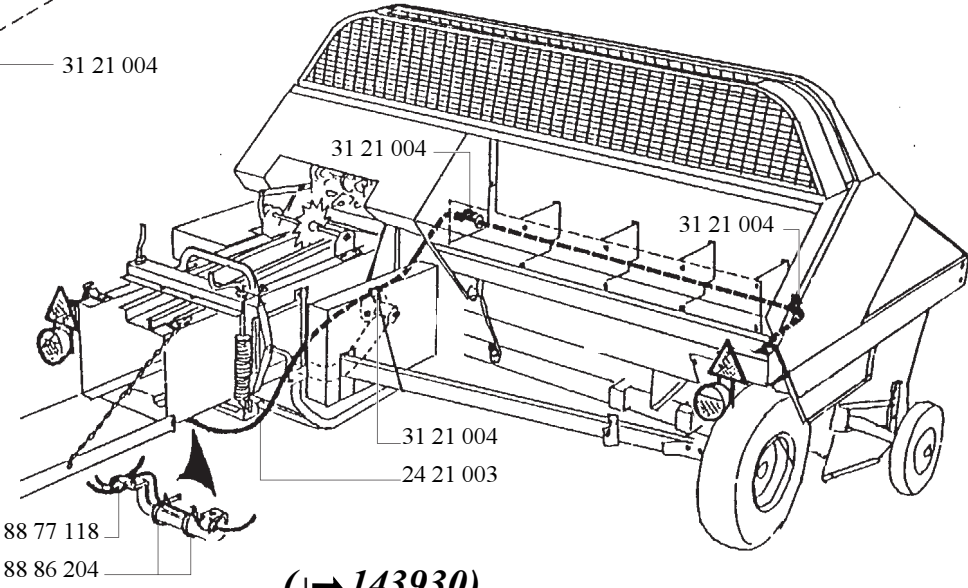
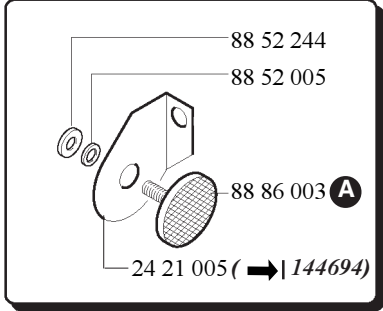
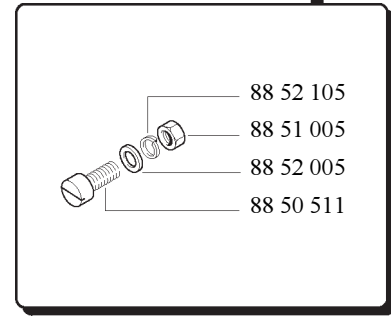
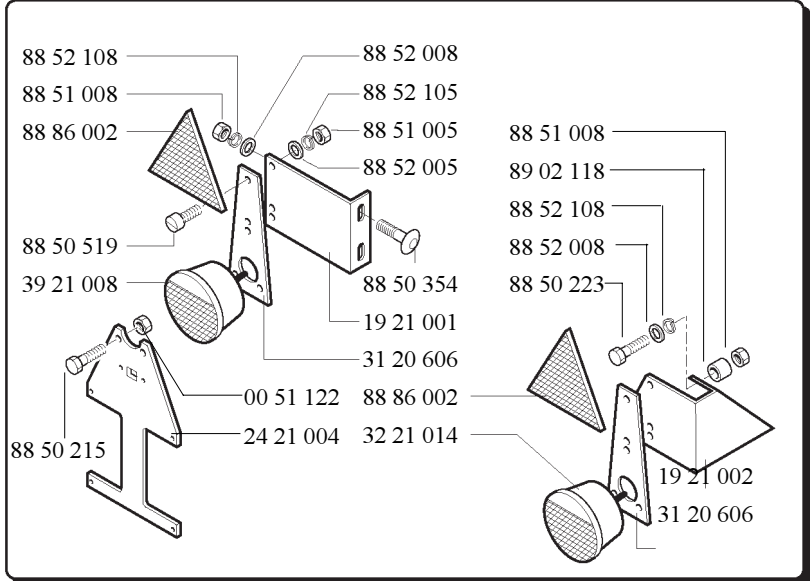
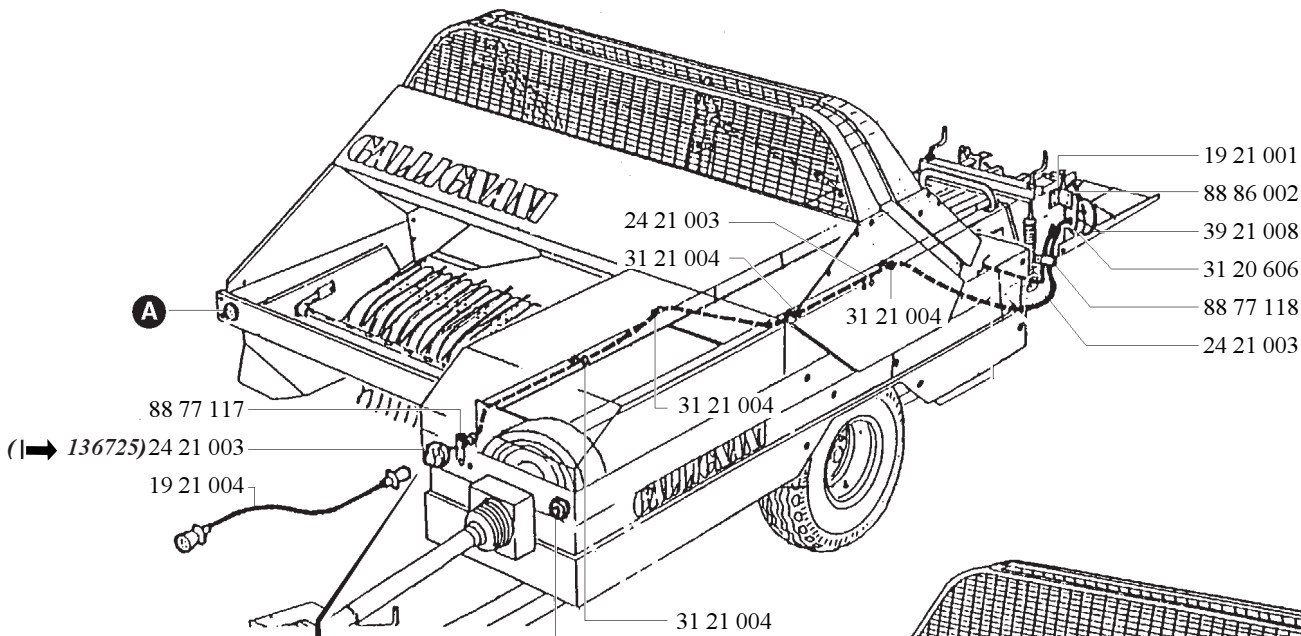

(1 → 143930)

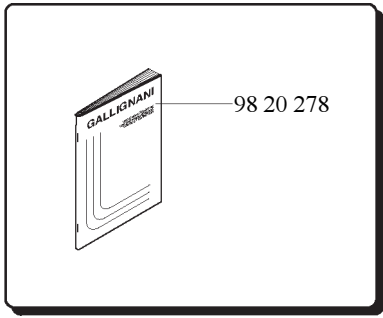

24 46 053

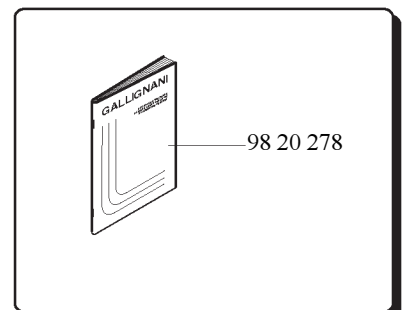
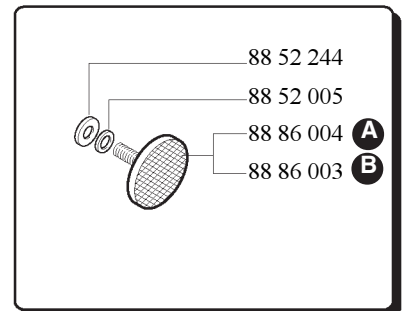
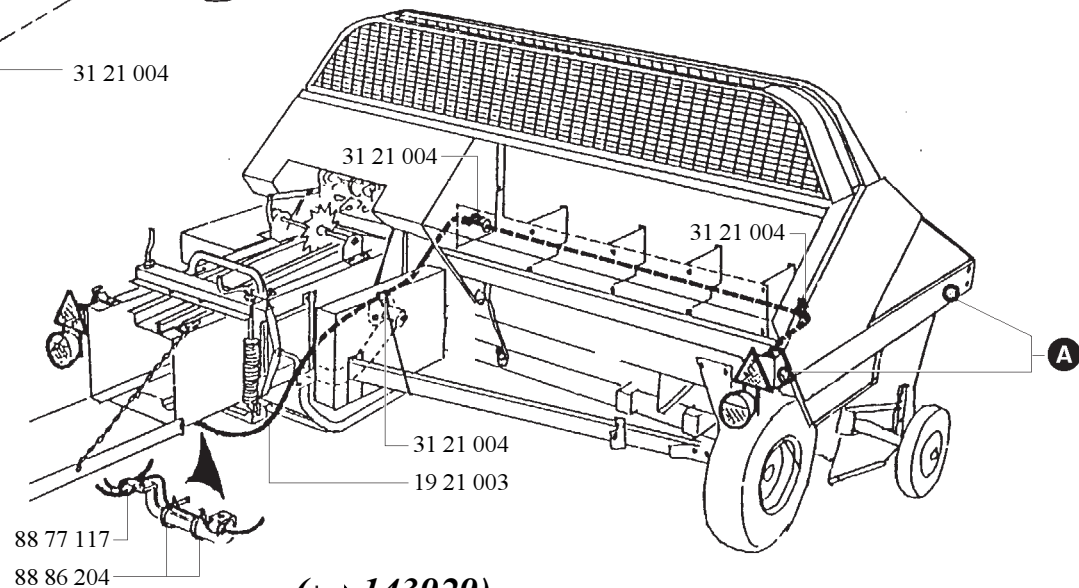
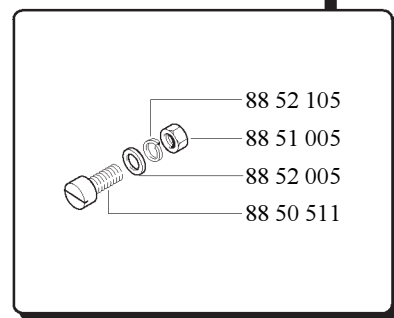
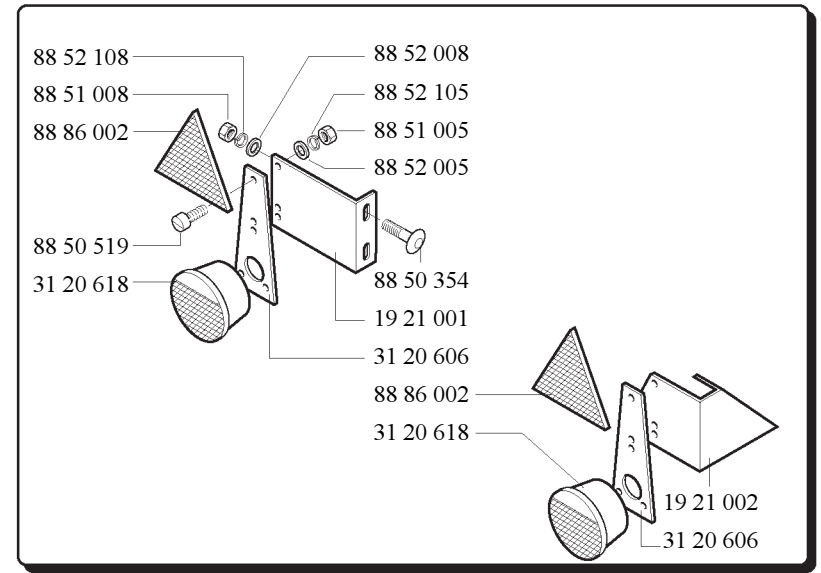
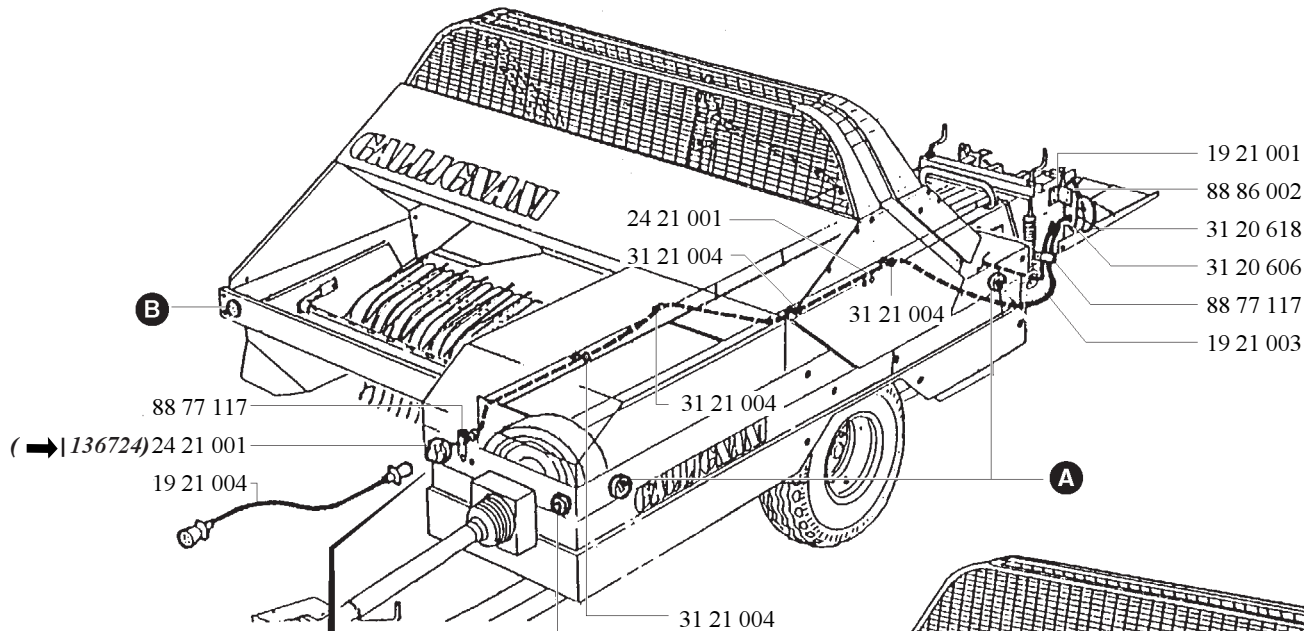

(1 → 143929)

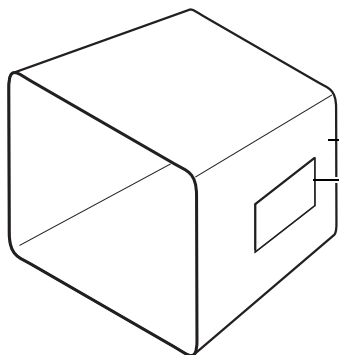

88 89 216
06 17 053

S 200
S 201
24 46 054

00 51 128
88 52 275
00 70 023
06 01 027
88 50 244

06 01 028
06 01 029
00 61 035
88 51 012
88 52 112
88 50 107

88 83 040
53 01 078
00 92 034

88 52 816

06 01 025
88 50 265
88 52 223
88 51 016

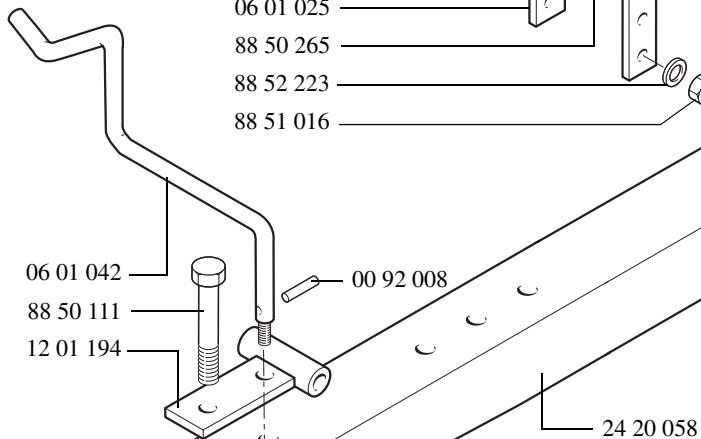

06 01 042
88 50 111
12 01 194
00 92 008

24 20 058

88 50 110
88 51 048
16 20 016
12 01 168

88 52 333
88 52 016
00 52 140
00 51 126
88 51 048

19 01 008
00 53 001
00 70 212
19 01 073

88 50 242
53 01 070
19 01 075
88 52 275
53 01 072
53 01 073
88 54 026
88 52 016
00 51 126
88 54 026
19 01 077

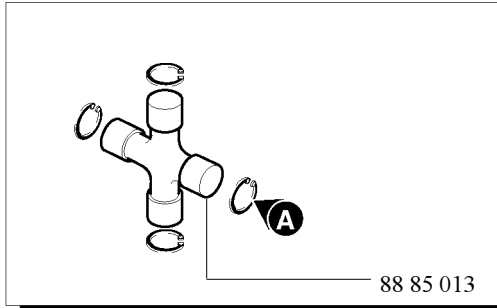

53 09 010

53 09 011

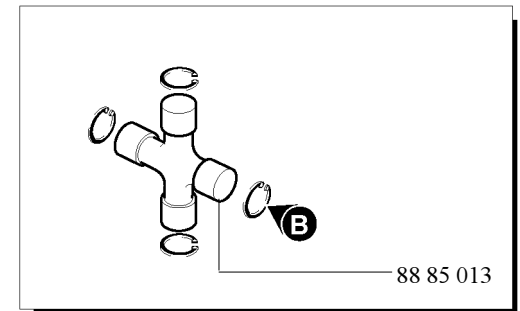
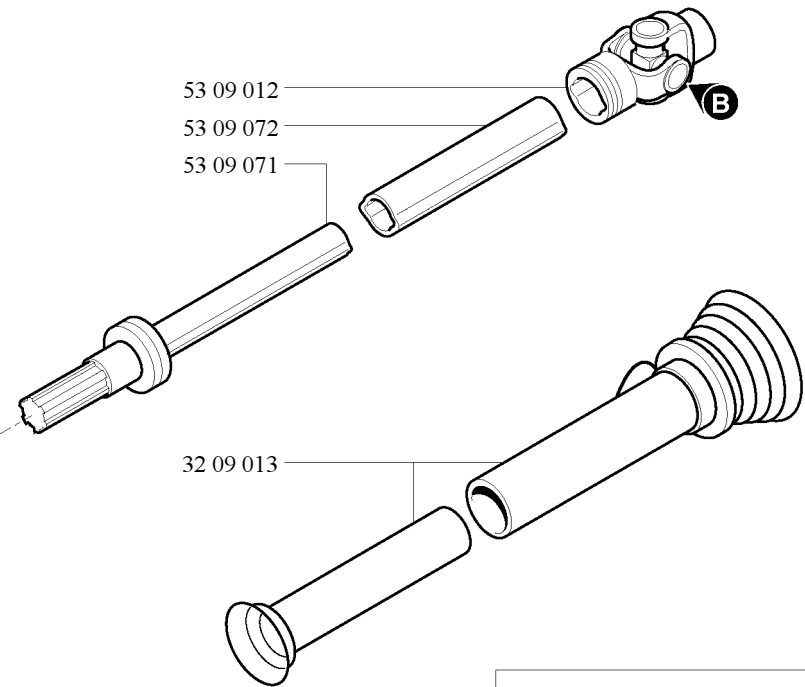
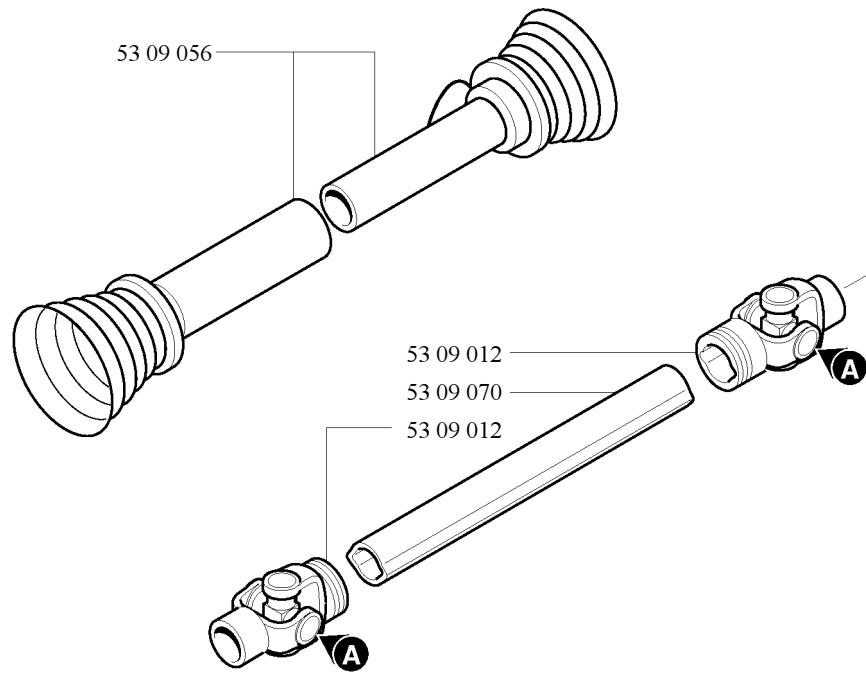

S200 ↗
 S201 ↖

24 46 054

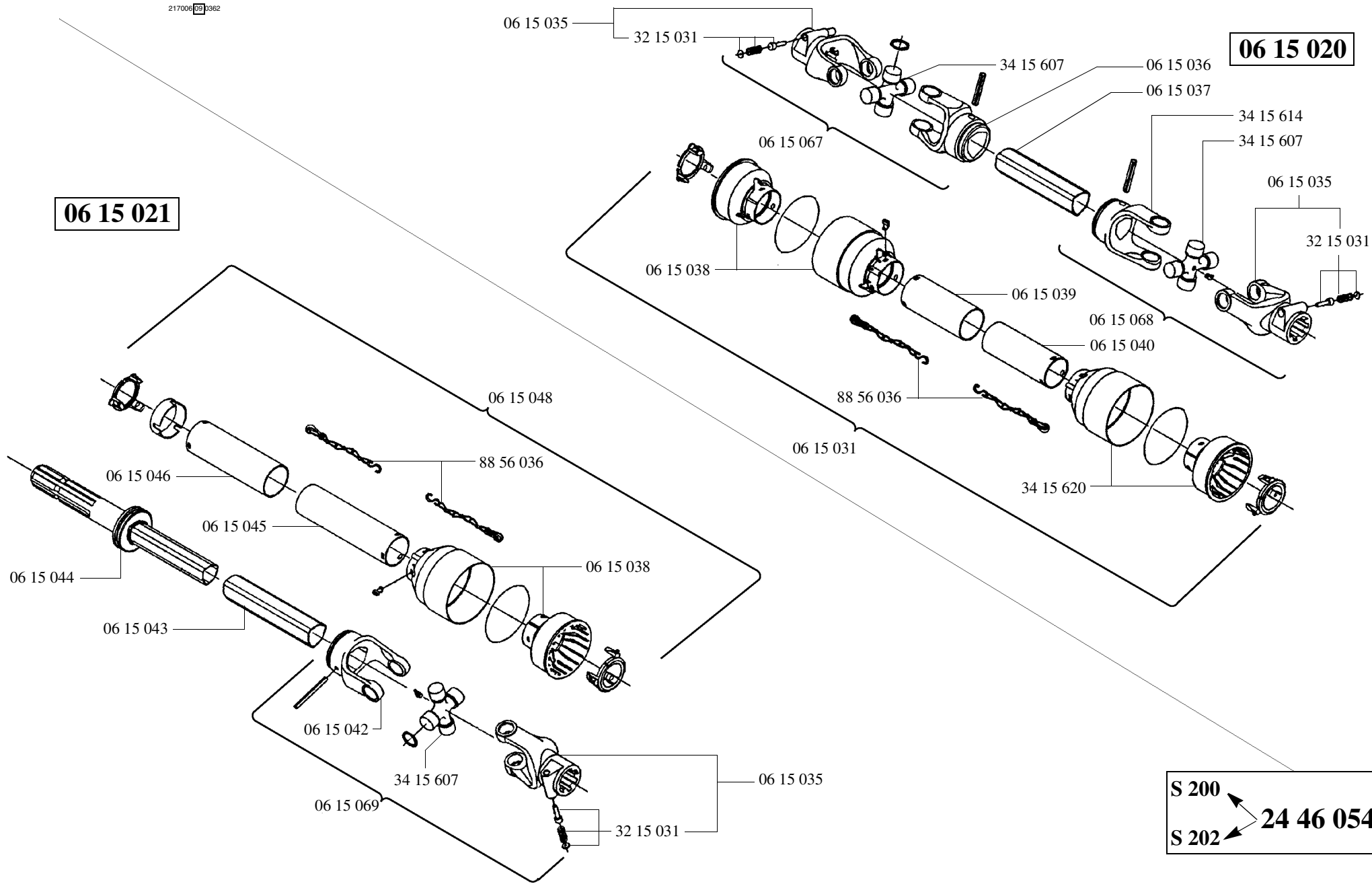

S 200
 S 202
24 46 054

98 20 622



24 46 070

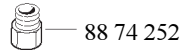
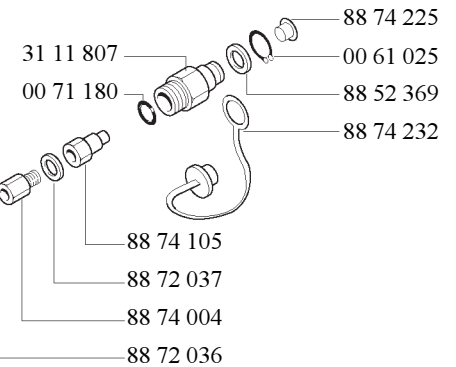
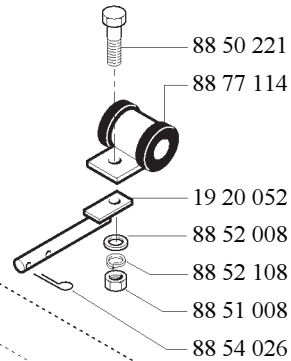

31 20 523

88 72 038
88 74 046
88 72 038
88 74 035
88 72 038

88 77 064

88 77 554

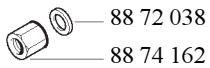
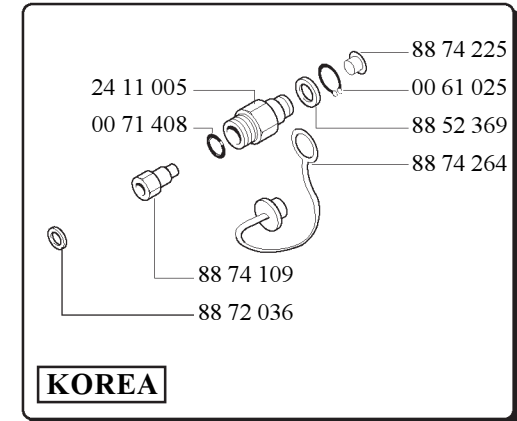

88 63 039
24 11 003

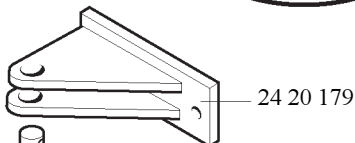

88 54 041
43 20 080

88 59 257

88 74 033
88 72 032
24 20 179

88 52 223
88 52 116

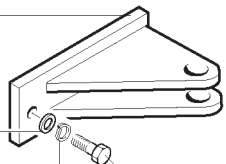

88 54 041
43 20 080
88 50 267

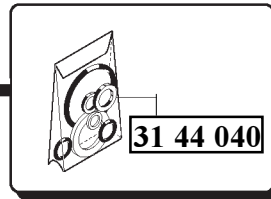

(I → 129889)

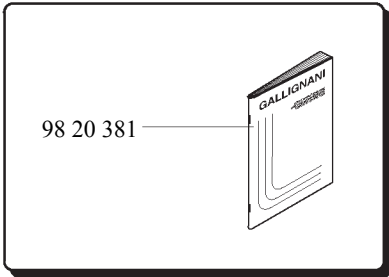

24 46 067

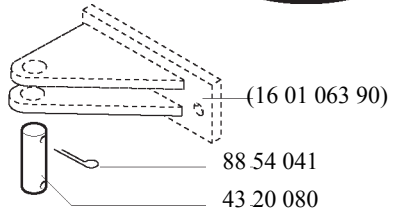
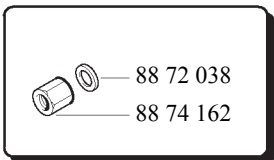
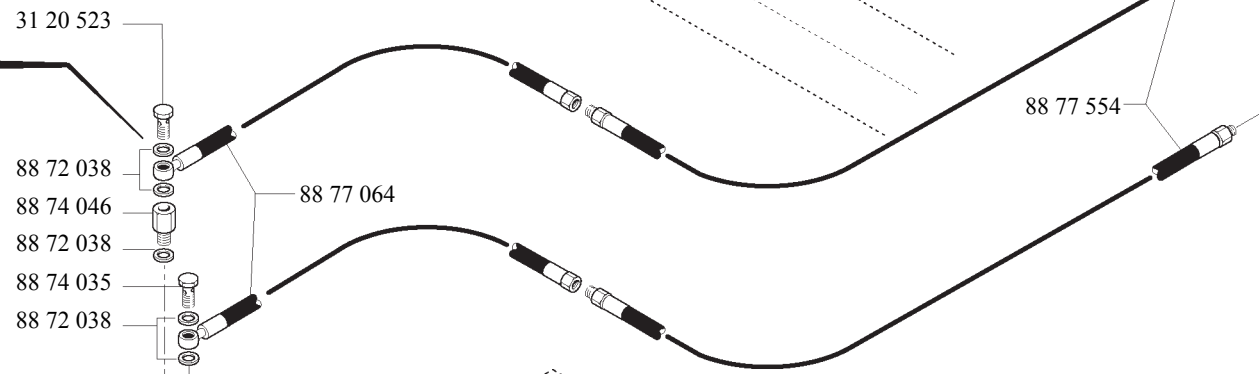
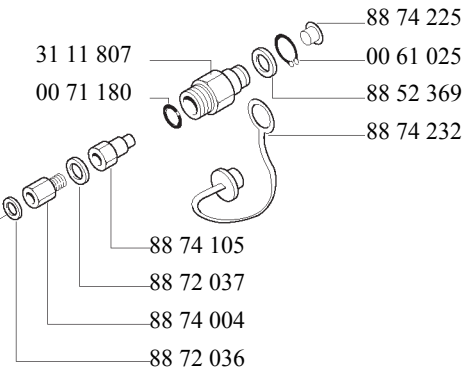
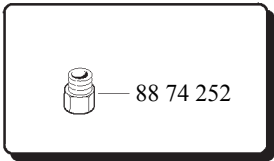
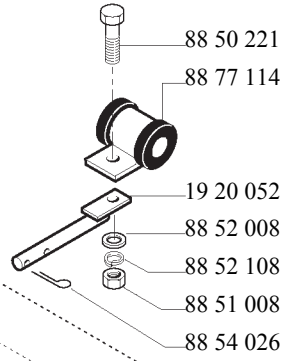

88 59 257

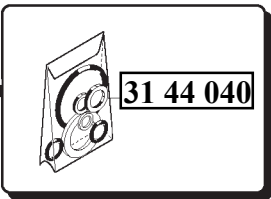
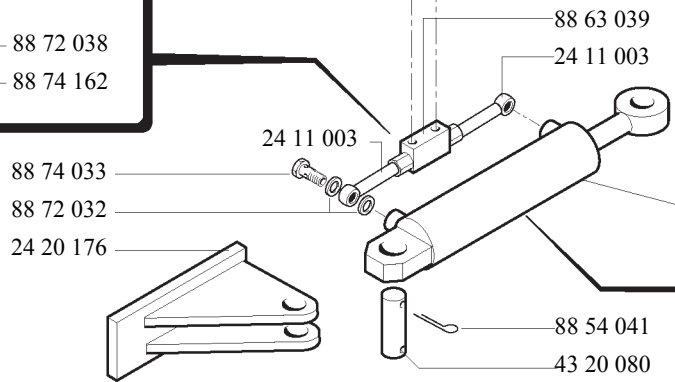

(→129888)

Codice Code	Tav. Tab.	Descrizione • Description • Description	Codice Code	Tav. Tab.	Descrizione • Description • Description	Codice Code	Tav. Tab.	Descrizione • Description • Description
00 51 122	B 10/5	Dado • Ecrou • Nut	00 51 125	F 20/1	Dado • Ecrou • Nut	00 53 005	F 10/5	Ingrassatore • Graisseur • Grease nipple
00 51 122	F 30/5	Dado • Ecrou • Nut	00 51 125	F 20/5	Dado • Ecrou • Nut	00 53 005	G 10/1	Ingrassatore • Graisseur • Grease nipple
00 51 122	N 20/5	Dado • Ecrou • Nut	00 51 125	N 20/5	Dado • Ecrou • Nut	00 53 005	G 10/5	Ingrassatore • Graisseur • Grease nipple
00 51 122	R 10/5	Dado • Ecrou • Nut	00 51 125	N 30/5	Dado • Ecrou • Nut	00 53 009	F 10/1	Ingrassatore • Graisseur • Grease nipple
00 51 122	S 190/5	Dado • Ecrou • Nut	00 51 126	A 50/4	Dado • Ecrou • Nut	00 53 009	F 10/1	Ingrassatore • Graisseur • Grease nipple
00 51 123	A 20/5	Dado • Ecrou • Nut	00 51 126	A 50/5	Dado • Ecrou • Nut	00 53 009	F 10/4	Ingrassatore • Graisseur • Grease nipple
00 51 123	C 10/5	Dado • Ecrou • Nut	00 51 126	A 51/4	Dado • Ecrou • Nut	00 53 009	F 10/4	Ingrassatore • Graisseur • Grease nipple
00 51 123	D 11/4	Dado • Ecrou • Nut	00 51 126	A 51/5	Dado • Ecrou • Nut	00 53 009	F 10/5	Ingrassatore • Graisseur • Grease nipple
00 51 123	D 11/5	Dado • Ecrou • Nut	00 51 126	E 10/5	Dado • Ecrou • Nut	00 53 009	F 10/5	Ingrassatore • Graisseur • Grease nipple
00 51 123	F 10/1	Dado • Ecrou • Nut	00 51 126	N 30/5	Dado • Ecrou • Nut	00 53 009	G 10/1	Ingrassatore • Graisseur • Grease nipple
00 51 123	F 10/4	Dado • Ecrou • Nut	00 51 126	S 140/5	Dado • Ecrou • Nut	00 53 009	G 10/1	Ingrassatore • Graisseur • Grease nipple
00 51 123	F 10/5	Dado • Ecrou • Nut	00 51 126	S 200/5	Dado • Ecrou • Nut	00 53 009	G 10/5	Ingrassatore • Graisseur • Grease nipple
00 51 123	F 20/1	Dado • Ecrou • Nut	00 51 126	S 200/5	Dado • Ecrou • Nut	00 53 009	G 10/5	Ingrassatore • Graisseur • Grease nipple
00 51 123	F 20/5	Dado • Ecrou • Nut	00 51 126	S 90/5	Dado • Ecrou • Nut	00 53 009	N 10/3	Ingrassatore • Graisseur • Grease nipple
00 51 123	G 30/5	Dado • Ecrou • Nut	00 51 127	A 20/5	Dado • Ecrou • Nut	00 53 009	N 10/5	Ingrassatore • Graisseur • Grease nipple
00 51 123	G 40/5	Dado • Ecrou • Nut	00 51 128	S 200/5	Dado • Ecrou • Nut	00 53 009	N 20/5	Ingrassatore • Graisseur • Grease nipple
00 51 123	G 40/5	Dado • Ecrou • Nut	00 51 130	E 30/5	Dado • Ecrou • Nut	00 53 009	N 20/5	Ingrassatore • Graisseur • Grease nipple
00 51 123	H 30/5	Dado • Ecrou • Nut	00 51 130	S 160/5	Dado • Ecrou • Nut	00 53 012	L 20/1	Ingrassatore • Graisseur • Grease nipple
00 51 123	N 30/5	Dado • Ecrou • Nut	00 51 137	C 10/5	Dado • Ecrou • Nut	00 53 016	F 10/1	Ingrassatore • Graisseur • Grease nipple
00 51 123	N 30/5	Dado • Ecrou • Nut	00 51 137	C 10/5	Dado • Ecrou • Nut	00 53 016	F 10/4	Ingrassatore • Graisseur • Grease nipple
00 51 123	P 30/5	Dado • Ecrou • Nut	00 51 137	C 10/5	Dado • Ecrou • Nut	00 53 016	F 10/5	Ingrassatore • Graisseur • Grease nipple
00 51 123	P 30/5	Dado • Ecrou • Nut	00 51 141	C 10/5	Dado • Ecrou • Nut	00 53 016	N 10/3	Ingrassatore • Graisseur • Grease nipple
00 51 123	P 30/5	Dado • Ecrou • Nut	00 51 141	H 20/5	Dado • Ecrou • Nut	00 53 016	N 10/5	Ingrassatore • Graisseur • Grease nipple
00 51 123	P 30/5	Dado • Ecrou • Nut	00 51 141	H 30/5	Dado • Ecrou • Nut	00 57 100	E 40/5	Morsetto • Borne • Cable retainer
00 51 123	P 30/5	Dado • Ecrou • Nut	00 52 140	S 200/5	Rondella • Rondelle • Washer	00 57 100	R 10/5	Morsetto • Borne • Cable retainer
00 51 123	P 50/5	Dado • Ecrou • Nut	00 52 416	S 110/4	Rondella • Rondelle • Washer	00 57 101	S 90/5	Morsetto • Borne • Cable retainer
00 51 123	P 50/5	Dado • Ecrou • Nut	00 52 416	S 110/5	Rondella • Rondelle • Washer	00 57 102	S 170/5	Morsetto • Borne • Cable retainer
00 51 123	P 60/5	Dado • Ecrou • Nut	00 52 416	S 130/5	Rondella • Rondelle • Washer	00 57 105	S 170/5	Morsetto • Borne • Cable retainer
00 51 123	P 60/5	Dado • Ecrou • Nut	00 52 416	S 30/5	Rondella • Rondelle • Washer	00 57 302	S 170/5	Redance • Cosses • Thimble
00 51 123	R 10/5	Dado • Ecrou • Nut	00 52 430	C 10/5	Rondella • Rondelle • Washer	00 57 351	R 10/5	Grillo • Manille • Clevis
00 51 123	S 140/5	Dado • Ecrou • Nut	00 52 430	C 10/5	Rondella • Rondelle • Washer	00 61 015	B 30/5	Anello • Bague • Ring
00 51 123	S 140/5	Dado • Ecrou • Nut	00 52 430	C 10/5	Rondella • Rondelle • Washer	00 61 015	B 30/5	Anello • Bague • Ring
00 51 124	A 10/5	Dado • Ecrou • Nut	00 53 001	A 20/5	Ingrassatore • Graisseur • Grease nipple	00 61 020	E 40/5	Anello • Bague • Ring
00 51 124	A 10/5	Dado • Ecrou • Nut	00 53 001	C 10/5	Ingrassatore • Graisseur • Grease nipple	00 61 025	S 160/5	Anello • Bague • Ring
00 51 124	A 30/5	Dado • Ecrou • Nut	00 53 001	D 11/5	Ingrassatore • Graisseur • Grease nipple	00 61 025	S 210/3	Anello • Bague • Ring
00 51 124	B 10/5	Dado • Ecrou • Nut	00 53 001	H 30/5	Ingrassatore • Graisseur • Grease nipple	00 61 025	S 210/5	Anello • Bague • Ring
00 51 124	E 20/5	Dado • Ecrou • Nut	00 53 001	N 10/3	Ingrassatore • Graisseur • Grease nipple	00 61 025	S 210/5	Anello • Bague • Ring
00 51 124	E 40/5	Dado • Ecrou • Nut	00 53 001	N 10/5	Ingrassatore • Graisseur • Grease nipple	00 61 028	H 30/5	Anello • Bague • Ring
00 51 124	E 50/4	Dado • Ecrou • Nut	00 53 001	N 20/5	Ingrassatore • Graisseur • Grease nipple	00 61 030	F 10/4	Anello • Bague • Ring
00 51 124	F 10/1	Dado • Ecrou • Nut	00 53 001	S 120/5	Ingrassatore • Graisseur • Grease nipple	00 61 030	F 10/5	Anello • Bague • Ring
00 51 124	F 10/4	Dado • Ecrou • Nut	00 53 001	S 200/5	Ingrassatore • Graisseur • Grease nipple	00 61 030	G 10/5	Anello • Bague • Ring
00 51 124	F 10/5	Dado • Ecrou • Nut	00 53 002	C 10/5	Ingrassatore • Graisseur • Grease nipple	00 61 035	B 10/5	Anello • Bague • Ring
00 51 124	G 30/5	Dado • Ecrou • Nut	00 53 002	D 11/4	Ingrassatore • Graisseur • Grease nipple	00 61 035	B 10/5	Anello • Bague • Ring
00 51 124	H 20/5	Dado • Ecrou • Nut	00 53 002	N 20/5	Ingrassatore • Graisseur • Grease nipple	00 61 035	B 20/5	Anello • Bague • Ring
00 51 124	L 21/5	Dado • Ecrou • Nut	00 53 002	N 40/5	Ingrassatore • Graisseur • Grease nipple	00 61 035	B 20/5	Anello • Bague • Ring
00 51 124	P 20/5	Dado • Ecrou • Nut	00 53 002	N 40/5	Ingrassatore • Graisseur • Grease nipple	00 61 035	C 10/5	Anello • Bague • Ring
00 51 124	P 20/5	Dado • Ecrou • Nut	00 53 005	E 20/5	Ingrassatore • Graisseur • Grease nipple	00 61 035	S 200/5	Anello • Bague • Ring
00 51 124	S 160/5	Dado • Ecrou • Nut	00 53 005	F 10/1	Ingrassatore • Graisseur • Grease nipple	00 61 040	G 40/5	Anello • Bague • Ring
00 51 124	S 170/5	Dado • Ecrou • Nut	00 53 005	F 10/4	Ingrassatore • Graisseur • Grease nipple	00 61 140	E 20/5	Anello • Bague • Ring

Codice Code	Tav. Tab.	Descrizione • Description • Description	Codice Code	Tav. Tab.	Descrizione • Description • Description	Codice Code	Tav. Tab.	Descrizione • Description • Description
00 61 172	C 10/5	Anello • Bague • Ring	00 70 040	A 50/5	Cuscinetto • Roulement • Bearing	00 75 232	A 51/4	Camera • Chambre • Chamber
00 61 172	L 20/5	Anello • Bague • Ring	00 70 040	A 51/4	Cuscinetto • Roulement • Bearing	00 75 232	A 51/4	Camera • Chambre • Chamber
00 61 172	L 20/5	Anello • Bague • Ring	00 70 040	A 51/5	Cuscinetto • Roulement • Bearing	00 75 233	A 50/4	Camera • Chambre • Chamber
00 61 172	L 21/5	Anello • Bague • Ring	00 70 043	D 10/5	Cuscinetto • Roulement • Bearing	00 75 233	A 50/4	Camera • Chambre • Chamber
00 61 172	L 21/5	Anello • Bague • Ring	00 70 043	D 10/5	Cuscinetto • Roulement • Bearing	00 75 242	S 130/5	Camera • Chambre • Chamber
00 61 180	L 20/1	Anello • Bague • Ring	00 70 043	D 10/5	Cuscinetto • Roulement • Bearing	00 84 001	D 10/5	Ghiera • Collier • Ring nut
00 62 104	B 20/5	Maglia • Maillon • Track link	00 70 056	D 10/5	Cuscinetto • Roulement • Bearing	00 84 003	D 10/5	Ghiera • Collier • Ring nut
00 62 114	B 20/5	Falsa maglia • Fausse maille • Closed link	00 70 189	C 10/5	Cuscinetto • Roulement • Bearing	00 84 020	S 130/5	Ghiera • Collier • Ring nut
00 65 402	B 30/5	Cinghia • Courroie • Belt	00 70 197	C 10/5	Cuscinetto • Roulement • Bearing	00 84 100	D 10/5	Rosetta • Rondelle • Washer
00 68 001	B 10/5	Chiavetta • Clè • Key	00 70 212	S 200/5	Cuscinetto • Roulement • Bearing	00 84 101	D 10/5	Rosetta • Rondelle • Washer
00 68 002	B 20/5	Chiavetta • Clè • Key	00 70 403	E 20/5	Cuscinetto • Roulement • Bearing	00 90 001	N 20/5	Ribattino • Rivet • Rivet
00 68 002	E 20/5	Chiavetta • Clè • Key	00 70 405	H 30/5	Cuscinetto • Roulement • Bearing	00 90 001	N 20/5	Ribattino • Rivet • Rivet
00 68 002	F 10/1	Chiavetta • Clè • Key	00 70 405	H 30/5	Cuscinetto • Roulement • Bearing	00 90 029	F 10/1	Ribattino • Rivet • Rivet
00 68 002	F 10/4	Chiavetta • Clè • Key	00 70 425	B 10/5	Cuscinetto • Roulement • Bearing	00 90 029	F 10/4	Ribattino • Rivet • Rivet
00 68 002	F 10/5	Chiavetta • Clè • Key	00 70 425	H 30/5	Cuscinetto • Roulement • Bearing	00 90 051	H 20/5	Ribattino • Rivet • Rivet
00 68 002	G 10/1	Chiavetta • Clè • Key	00 70 425	N 20/1	Cuscinetto • Roulement • Bearing	00 90 051	H 30/5	Ribattino • Rivet • Rivet
00 68 002	G 10/5	Chiavetta • Clè • Key	00 70 461	B 30/5	Cuscinetto • Roulement • Bearing	00 90 051	H 30/5	Ribattino • Rivet • Rivet
00 68 003	N 20/1	Chiavetta • Clè • Key	00 70 461	B 30/5	Cuscinetto • Roulement • Bearing	00 90 051	H 30/5	Ribattino • Rivet • Rivet
00 68 010	F 10/1	Chiavetta • Clè • Key	00 70 506	C 10/5	Rullo • Galet • Roller	00 90 051	H 30/5	Ribattino • Rivet • Rivet
00 68 022	C 10/5	Chiavetta • Clè • Key	00 70 506	C 10/5	Rullo • Galet • Roller	00 90 051	H 30/5	Ribattino • Rivet • Rivet
00 68 033	N 20/5	Chiavetta • Clè • Key	00 71 015	D 10/5	Paraolio • Pare huile • Oil seal	00 90 052	H 30/5	Ribattino • Rivet • Rivet
00 68 033	N 20/5	Chiavetta • Clè • Key	00 71 028	A 50/4	Paraolio • Pare huile • Oil seal	00 90 401	N 20/1	Rivetto • Rivet • Rivet
00 68 104	G 10/1	Chiavetta • Clè • Key	00 71 028	A 50/5	Paraolio • Pare huile • Oil seal	00 92 001	S 30/5	Spina • Goupille • Pin
00 68 127	B 10/5	Chiavetta • Clè • Key	00 71 028	A 51/4	Paraolio • Pare huile • Oil seal	00 92 003	N 20/1	Spina • Goupille • Pin
00 69 035	E 20/5	Cuscinetto • Roulement • Bearing	00 71 028	A 51/5	Paraolio • Pare huile • Oil seal	00 92 007	D 11/4	Spina • Goupille • Pin
00 69 201	N 20/1	Flangia • Flasque • Flange	00 71 051	D 10/5	Paraolio • Pare huile • Oil seal	00 92 007	D 11/5	Spina • Goupille • Pin
00 69 201	N 20/1	Flangia • Flasque • Flange	00 71 158	D 10/5	Paraolio • Pare huile • Oil seal	00 92 008	E 10/5	Spina • Goupille • Pin
00 69 204	E 20/5	Flangia • Flasque • Flange	00 71 180	S 160/5	Paraolio • Pare huile • Oil seal	00 92 008	P 20/5	Spina • Goupille • Pin
00 70 022	H 30/5	Cuscinetto • Roulement • Bearing	00 71 180	S 210/3	Paraolio • Pare huile • Oil seal	00 92 008	S 200/5	Spina • Goupille • Pin
00 70 022	H 30/5	Cuscinetto • Roulement • Bearing	00 71 180	S 210/5	Paraolio • Pare huile • Oil seal	00 92 009	B 10/5	Spina • Goupille • Pin
00 70 022	S 130/5	Cuscinetto • Roulement • Bearing	00 71 201	C 10/5	Protezione • Protection • Guard	00 92 010	G 10/1	Spina • Goupille • Pin
00 70 022	S 130/5	Cuscinetto • Roulement • Bearing	00 71 401	G 30/5	Guarnizione • Joint • Seal	00 92 010	G 10/1	Spina • Goupille • Pin
00 70 023	B 10/5	Cuscinetto • Roulement • Bearing	00 71 401	G 30/5	Guarnizione • Joint • Seal	00 92 010	G 10/1	Spina • Goupille • Pin
00 70 023	B 20/5	Cuscinetto • Roulement • Bearing	00 71 408	S 210/5	Guarnizione • Joint • Seal	00 92 010	G 10/1	Spina • Goupille • Pin
00 70 023	B 30/5	Cuscinetto • Roulement • Bearing	00 72 002	D 10/5	Guarnizione • Joint • Seal	00 92 010	G 10/1	Spina • Goupille • Pin
00 70 023	B 30/5	Cuscinetto • Roulement • Bearing	00 72 005	D 10/5	Guarnizione • Joint • Seal	00 92 010	G 10/1	Spina • Goupille • Pin
00 70 023	H 20/5	Cuscinetto • Roulement • Bearing	00 75 110	S 50/5	Pneumatico • Pneu • Tyre	00 92 010	G 10/5	Spina • Goupille • Pin
00 70 023	H 20/5	Cuscinetto • Roulement • Bearing	00 75 123	S 50/5	Pneumatico • Pneu • Tyre	00 92 010	G 10/5	Spina • Goupille • Pin
00 70 023	S 200/5	Cuscinetto • Roulement • Bearing	00 75 127	S 130/5	Pneumatico • Pneu • Tyre	00 92 010	G 10/5	Spina • Goupille • Pin
00 70 024	B 10/5	Cuscinetto • Roulement • Bearing	00 75 141	A 51/4	Pneumatico • Pneu • Tyre	00 92 010	G 10/5	Spina • Goupille • Pin
00 70 024	B 10/5	Cuscinetto • Roulement • Bearing	00 75 142	A 50/4	Pneumatico • Pneu • Tyre	00 92 010	G 10/5	Spina • Goupille • Pin
00 70 024	B 20/5	Cuscinetto • Roulement • Bearing	00 75 159	S 130/5	Pneumatico • Pneu • Tyre	00 92 010	G 10/5	Spina • Goupille • Pin
00 70 024	H 20/5	Cuscinetto • Roulement • Bearing	00 75 161	A 50/4	Pneumatico • Pneu • Tyre	00 92 012	C 10/5	Spina • Goupille • Pin
00 70 024	H 30/5	Cuscinetto • Roulement • Bearing	00 75 162	A 51/4	Pneumatico • Pneu • Tyre	00 92 014	N 20/1	Spina • Goupille • Pin
00 70 035	A 50/4	Cuscinetto • Roulement • Bearing	00 75 171	A 51/5	Pneumatico • Pneu • Tyre	00 92 020	E 50/4	Spina • Goupille • Pin
00 70 035	A 50/5	Cuscinetto • Roulement • Bearing	00 75 172	A 50/5	Pneumatico • Pneu • Tyre	00 92 020	E 50/4	Spina • Goupille • Pin
00 70 035	A 51/4	Cuscinetto • Roulement • Bearing	00 75 207	S 50/5	Camera • Chambre • Chamber	00 92 020	L 10/3	Spina • Goupille • Pin
00 70 035	A 51/5	Cuscinetto • Roulement • Bearing	00 75 208	S 50/5	Camera • Chambre • Chamber	00 92 020	L 10/3	Spina • Goupille • Pin
00 70 040	A 50/4	Cuscinetto • Roulement • Bearing	00 75 221	S 130/5	Camera • Chambre • Chamber	00 92 020	L 10/3	Spina • Goupille • Pin

Codice Code	Tav. Tab.	Descrizione • Description • Description	Codice Code	Tav. Tab.	Descrizione • Description • Description	Codice Code	Tav. Tab.	Descrizione • Description • Description
00 92 020	L 10/3	Spina • Goupille • Pin	05 01 037	A 10/5	Rosetta • Rondelle • Washer	06 01 280	A 50/4	Mozzo • Moyeu • Hub
00 92 020	L 10/5	Spina • Goupille • Pin	05 01 037	A 10/5	Rosetta • Rondelle • Washer	06 01 280	A 51/4	Mozzo • Moyeu • Hub
00 92 020	L 10/5	Spina • Goupille • Pin	05 01 071	A 20/5	Vite • Vis • Screw	06 01 282	A 50/4	Coperchio • Couverture • Cover
00 92 020	L 10/5	Spina • Goupille • Pin	05 02 014	E 20/5	Coperchio • Couvercle • Cover	06 01 282	A 50/5	Coperchio • Couvercle • Cover
00 92 020	L 10/5	Spina • Goupille • Pin	05 05 021	G 10/1	Rullo • Galet • Roller	06 01 282	A 51/4	Coperchio • Couvercle • Cover
00 92 021	G 10/1	Spina • Goupille • Pin	05 05 021	G 10/5	Rullo • Galet • Roller	06 01 282	A 51/5	Coperchio • Couvercle • Cover
00 92 021	G 10/5	Spina • Goupille • Pin	05 05 035	E 40/5	Carrucola • Poulie • Pulley	06 01 282	S 130/5	Coperchio • Couvercle • Cover
00 92 025	N 30/5	Spina • Goupille • Pin	05 05 037	E 40/5	Nottolino • Cliquet • Pawl	06 03 075	C 20/5	Spessore • Epaisseur • Shim
00 92 026	A 20/5	Spina • Goupille • Pin	05 05 038	E 40/5	Nottolino • Cliquet • Pawl	06 03 076	C 20/5	Spessore • Epaisseur • Shim
00 92 026	H 20/5	Spina • Goupille • Pin	05 05 039	E 40/5	Camma • Came • Cam	06 03 077	C 20/5	Spessore • Epaisseur • Shim
00 92 026	H 20/5	Spina • Goupille • Pin	05 06 029	F 20/5	Asta • Tige • Rod	06 03 078	C 20/5	Spessore • Epaisseur • Shim
00 92 027	E 40/5	Spina • Goupille • Pin	05 06 033	F 20/1	Camma • Came • Cam	06 05 013	E 20/5	Guida • Guide • Guide
00 92 027	E 40/5	Spina • Goupille • Pin	05 06 033	F 20/5	Camma • Came • Cam	06 05 014	E 20/5	Guida • Guide • Guide
00 92 027	S 170/5	Spina • Goupille • Pin	05 06 041	F 30/5	Ago • Aiguille • Needle	06 05 014	R 10/5	Guida • Guide • Guide
00 92 029	A 20/5	Spina • Goupille • Pin	05 07 027	G 30/5	Carrucola • Poulie • Pulley	06 05 018	E 20/5	Boccola • Douille • Bushing
00 92 034	N 30/5	Spina • Goupille • Pin	05 07 028	G 30/5	Perno • Pivot • Pin	06 05 018	E 20/5	Boccola • Douille • Bushing
00 92 034	S 200/5	Spina • Goupille • Pin	05 07 031	G 30/5	Carrucola • Poulie • Pulley	06 05 037	E 20/5	Flangia • Flasque • Flange
00 92 037	N 20/1	Spina • Goupille • Pin	05 07 031	G 30/5	Carrucola • Poulie • Pulley	06 05 038	E 20/5	Disco • Disque • Disk
00 92 046	N 20/1	Spina • Goupille • Pin	05 07 031	S 170/5	Carrucola • Poulie • Pulley	06 05 038	E 20/5	Disco • Disque • Disk
00 92 047	E 40/5	Spina • Goupille • Pin	05 07 032	G 30/5	Piastra • Plaque • Plate	06 05 038	E 20/5	Disco • Disque • Disk
00 92 047	E 40/5	Spina • Goupille • Pin	05 07 032	G 30/5	Piastra • Plaque • Plate	06 05 054	E 40/5	Piastra • Plaque • Plate
00 92 048	B 30/5	Spina • Goupille • Pin	05 07 032	S 170/5	Piastra • Plaque • Plate	06 05 063	S 160/5	Piastra • Plaque • Plate
00 92 056	G 10/1	Spina • Goupille • Pin	05 07 037	G 10/1	Distanziale • Entretoise • Spacer	06 05 064	S 160/5	Staffa • Bride • Bracket
00 92 056	G 10/5	Spina • Goupille • Pin	05 07 037	G 10/5	Distanziale • Entretoise • Spacer	06 05 065	E 30/5	Piatto • Plateau • Plate
00 92 200	F 10/1	Spina • Goupille • Pin	05 07 067	G 30/5	Ago • Aiguille • Needle	06 05 065	S 160/5	Piatto • Plateau • Plate
00 92 200	F 10/1	Spina • Goupille • Pin	05 16 009	N 20/1	Rullo • Galet • Roller	06 05 076	E 20/5	Mozzo • Moyeu • Hub
00 92 200	F 10/1	Spina • Goupille • Pin	05 16 009	N 20/5	Rullo • Galet • Roller	06 05 161	E 40/5	Leva • Levier • Lever
00 92 200	F 10/4	Spina • Goupille • Pin	05 16 030	F 20/5	Rullo • Galet • Roller	06 05 233	E 20/5	Copripolvere • Protecteur de poussière • Dust cover
00 92 200	F 10/4	Spina • Goupille • Pin	05 16 030	G 10/1	Rullo • Galet • Roller	06 05 411	E 20/5	Tube • Tuyau • Hose
00 92 200	F 10/4	Spina • Goupille • Pin	05 16 030	N 20/5	Rullo • Galet • Roller	06 05 415	E 10/5	Fascetta • Collier • Clamp
00 92 200	F 10/5	Spina • Goupille • Pin	05 16 031	F 20/1	Attacco • Connexion • Connection	06 05 416	E 10/5	Fascetta • Collier • Clamp
00 92 200	F 10/5	Spina • Goupille • Pin	05 16 031	F 20/5	Attacco • Connexion • Connection	06 05 441	E 10/5	Fascetta • Collier • Clamp
00 92 200	F 10/5	Spina • Goupille • Pin	05 16 031	G 20/5	Attacco • Connexion • Connection	06 05 450	E 30/5	Piatto • Plateau • Plate
00 92 206	N 20/5	Spina • Goupille • Pin	05 16 031	N 20/5	Attacco • Connexion • Connection	06 06 007	F 10/1	Perno • Pivot • Pin
04 05 044	E 30/5	Supporto • Support • Support	05 16 032	F 20/1	Tirante • Tirant • Tie rod	06 06 007	F 10/4	Perno • Pivot • Pin
04 05 054	E 30/5	Piatto • Plateau • Plate	05 16 032	F 20/5	Tirante • Tirant • Tie rod	06 06 007	F 10/5	Perno • Pivot • Pin
04 09 004	L 10/5	Albero • Arbre • Shaft	05 16 043	N 10/3	Supporto • Support • Support	06 06 010	F 10/1	Corpo • Corps • Body
04 09 008	L 10/5	Albero • Arbre • Shaft	05 16 057	F 20/1	Rullo • Galet • Roller	06 06 010	F 10/4	Corpo • Corps • Body
04 09 012	L 10/3	Disco • Disque • Disk	05 16 057	N 30/5	Rullo • Galet • Roller	06 06 010	F 10/5	Corpo • Corps • Body
04 09 013	L 10/3	Disco • Disque • Disk	05 16 066	G 10/1	Asta • Tige • Rod	06 06 011	F 10/1	Camma • Came • Cam
04 09 013	L 10/3	Disco • Disque • Disk	05 16 066	N 20/5	Asta • Tige • Rod	06 06 011	F 10/4	Camma • Came • Cam
04 09 043	L 10/5	Tubo cardanico • Tuyau arbre • Hose shaft	05 20 024	S 30/5	Rullo • Galet • Roller	06 06 011	F 10/5	Camma • Came • Cam
04 09 044	L 10/5	Tubo cardanico • Tuyau arbre • Hose shaft	06 01 025	S 200/5	Supporto • Support • Support	06 06 012	F 10/1	Ingranaggio • Engrenage • Gear
04 09 045	L 10/5	Protezione • Protection • Guard	06 01 027	S 200/5	Supporto • Support • Support	06 06 012	F 10/4	Ingranaggio • Engrenage • Gear
04 09 046	L 10/5	Protezione • Protection • Guard	06 01 028	S 200/5	Piastra • Plaque • Plate	06 06 012	F 10/5	Ingranaggio • Engrenage • Gear
04 09 047	L 10/5	Protezione • Protection • Guard	06 01 029	S 200/5	Distanziale • Entretoise • Spacer	06 06 013	F 10/1	Albero • Arbre • Shaft
04 09 048	L 10/5	Tubo cardanico • Tuyau arbre • Hose shaft	06 01 042	S 200/5	Supporto • Support • Support	06 06 013	F 10/4	Albero • Arbre • Shaft
04 09 049	L 10/5	Tubo cardanico • Tuyau arbre • Hose shaft	06 01 126	A 10/5	Rinforzo • Renforcement • Reinforcement	06 06 013	F 10/5	Albero • Arbre • Shaft
05 01 036	A 10/5	Tirante • Tirant • Tie rod	06 01 226	A 10/5	Rinforzo • Renforcement • Reinforcement	06 06 014	F 10/1	Vite • Vis • Screw

Codice Code	Tav. Tab.	Descrizione • Description • Description	Codice Code	Tav. Tab.	Descrizione • Description • Description	Codice Code	Tav. Tab.	Descrizione • Description • Description
06 06 014	F 10/4	Vite • Vis • Screw	06 07 265	G 40/5	Cassa • Boîte • Casing	06 16 199	N 10/3	Occhiello • Boucle • Eye
06 06 014	F 10/5	Vite • Vis • Screw	06 07 265	G 40/5	Cassa • Boîte • Casing	06 16 199	N 10/5	Occhiello • Boucle • Eye
06 06 015	F 10/1	Ingranaggio • Engrenage • Gear	06 07 266	G 40/5	Forcella • Fourche • Fork	06 17 051	P 60/5	Staffa • Bride • Bracket
06 06 015	F 10/4	Ingranaggio • Engrenage • Gear	06 08 058	H 30/5	Perno • Pivot • Pin	06 17 053	S 200/5	Protezione • Protection • Guard
06 06 015	F 10/5	Ingranaggio • Engrenage • Gear	06 09 002	L 20/1	Piatto • Plateau • Plate	06 17 085	P 11/5	Rinforzo • Renforcement • Reinforcement
06 06 016	F 10/1	Rullo • Galet • Roller	06 09 002	L 20/1	Piatto • Plateau • Plate	06 17 113	N 10/5	Protezione • Protection • Guard
06 06 016	F 10/4	Rullo • Galet • Roller	06 09 004	L 20/5	Disco • Disque • Disk	06 17 340	D 11/4	Protezione • Protection • Guard
06 06 016	F 10/5	Rullo • Galet • Roller	06 09 004	L 20/5	Disco • Disque • Disk	06 17 340	D 11/5	Protezione • Protection • Guard
06 06 017	F 10/1	Lamiera • Tôle • Plate	06 15 020	S 202/5	Albero cardanico • Arbre à cardan • Cardan shaft	06 20 005	S 120/5	Distanziale • Entretoise • Spacer
06 06 017	F 10/4	Lamiera • Tôle • Plate	06 15 021	S 202/5	Albero cardanico • Arbre à cardan • Cardan shaft	06 20 076	S 90/5	Perno • Pivot • Pin
06 06 017	F 10/5	Lamiera • Tôle • Plate	06 15 022	L 21/5	Frizione • Embrayage • Clutch	06 20 107	S 140/5	Piastra • Plaque • Plate
06 06 018	F 10/1	Dito • Doigt • Finger	06 15 031	S 202/5	Protezione • Protection • Guard	06 20 120	S 110/4	Staffa • Bride • Bracket
06 06 018	F 10/4	Dito • Doigt • Finger	06 15 035	S 202/5	Giunto • Joint • Joint	06 20 120	S 110/5	Staffa • Bride • Bracket
06 06 018	F 10/5	Dito • Doigt • Finger	06 15 035	S 202/5	Giunto • Joint • Joint	06 20 120	S 30/5	Staffa • Bride • Bracket
06 06 019	F 10/1	Perno • Pivot • Pin	06 15 035	S 202/5	Giunto • Joint • Joint	06 44 005	S 110/4	Mozzo completo • Moyeu complet • Complete rotor flange
06 06 019	F 10/4	Perno • Pivot • Pin	06 15 036	S 202/5	Giunto • Joint • Joint	06 44 009	E 20/5	Flangia completa • Flasque complète • Complete flange
06 06 019	F 10/5	Perno • Pivot • Pin	06 15 037	S 202/5	Tubo cardanico • Tuyau arbre • Hose shaft	06 44 010	E 20/5	Flangia completa • Flasque complète • Complete flange
06 06 023	F 10/1	Ingranaggio • Engrenage • Gear	06 15 038	S 202/5	Cuffia • Protecteur • Protection	06 44 010	E 20/5	Flangia completa • Flasque complète • Complete flange
06 06 023	F 10/4	Ingranaggio • Engrenage • Gear	06 15 038	S 202/5	Cuffia • Protecteur • Protection	06 44 011	F 10/4	Legatore • Lieur • Knotter
06 06 023	F 10/5	Ingranaggio • Engrenage • Gear	06 15 039	S 202/5	Protezione • Protection • Guard	06 44 011	F 10/5	Legatore • Lieur • Knotter
06 06 025	F 10/1	Rullo • Galet • Roller	06 15 040	S 202/5	Protezione • Protection • Guard	06 44 013	F 10/1	Braccio • Bras • Arm
06 06 028	F 10/1	Camma • Came • Cam	06 15 042	S 202/5	Giunto • Joint • Joint	06 44 013	F 10/4	Braccio • Bras • Arm
06 06 028	F 10/4	Camma • Came • Cam	06 15 043	S 202/5	Tubo cardanico • Tuyau arbre • Hose shaft	06 44 024	N 10/3	Tubo lubrificazione • Tuyau de graissage • Lubrication hose
06 06 028	F 10/5	Camma • Came • Cam	06 15 044	S 202/5	Albero • Arbre • Shaft	06 44 024	N 10/5	Tubo lubrificazione • Tuyau de graissage • Lubrication hose
06 06 036	F 10/4	Braccio • Bras • Arm	06 15 045	S 202/5	Protezione • Protection • Guard	06 44 036	F 10/5	Braccio • Bras • Arm
06 06 040	F 10/5	Braccio • Bras • Arm	06 15 046	S 202/5	Protezione • Protection • Guard	06 44 039	S 110/5	Mozzo completo • Moyeu complet • Complete rotor flange
06 06 222	F 10/1	Becco • Bec • Billhook	06 15 048	S 202/5	Protezione • Protection • Guard	06 46 101	S 10/4	Lubrificazione centralizzata • Librification centralisée Centralized lubrication
06 06 222	F 10/4	Becco • Bec • Billhook	06 15 049	L 21/5	Flangia • Flasque • Flange	06 46 101	S 10/5	Lubrificazione centralizzata • Librification centralisée Centralized lubrication
06 06 222	F 10/5	Becco • Bec • Billhook	06 15 050	L 21/5	Bronzina • Coussinet • Bushing	06 46 102	S 20/4	Lubrificazione centralizzata • Librification centralisée Centralized lubrication
06 06 224	F 10/1	Coltello • Couteau • Knife	06 15 051	L 21/5	Disco • Disque • Disk	06 46 102	S 20/5	Lubrificazione centralizzata • Librification centralisée Centralized lubrication
06 06 224	F 10/4	Coltello • Couteau • Knife	06 15 051	L 21/5	Disco • Disque • Disk	06 46 102	S 21/4	Lubrificazione centralizzata • Librification centralisée Centralized lubrication
06 06 224	F 10/5	Coltello • Couteau • Knife	06 15 052	L 21/5	Corpo • Corps • Body	06 46 102	S 21/5	Lubrificazione centralizzata • Librification centralisée Centralized lubrication
06 07 050	G 30/5	Guidafilo • Guide-fil • Twine-guide	06 15 053	L 21/5	Disco • Disque • Disk	06 46 106	S 30/5	Rullo di sostegno in ferro • rouleau de support en fer iron bearing roller
06 07 080	G 30/5	Appoggio • Appui • Support	06 15 054	L 21/5	Disco • Disque • Disk	06 46 110	S 40/5	Contaballe • Compteur de balles • Bale counteur
06 07 081	G 30/5	Guidafilo • Guide-fil • Twine-guide	06 15 055	L 21/5	Bronzina • Coussinet • Bushing	07 09 006	L 20/1	Spina • Goupille • Pin
06 07 082	G 30/5	Manicotto • Manchon • Sleeve	06 15 056	L 21/5	Distanziale • Entretoise • Spacer	08 05 014	E 20/5	Guida • Guide • Guide
06 07 082	G 30/5	Manicotto • Manchon • Sleeve	06 15 056	L 21/5	Distanziale • Entretoise • Spacer	09 07 103	G 10/1	Corpo • Corps • Body
06 07 082	G 30/5	Manicotto • Manchon • Sleeve	06 15 057	L 21/5	Molla • Ressort • Spring	09 07 103	G 10/5	Corpo • Corps • Body
06 07 082	G 30/5	Manicotto • Manchon • Sleeve	06 15 058	L 21/5	Molla • Ressort • Spring	09 07 176	G 20/5	Estrattore • Extracteur • Puller
06 07 083	G 30/5	Perno • Pivot • Pin	06 15 059	L 21/5	Mozzo • Moyeu • Hub	12 01 008	A 10/5	Scivolo • Glissière • Chute
06 07 083	G 30/5	Perno • Pivot • Pin	06 15 067	S 202/5	Giunto • Joint • Joint	12 01 015	R 10/5	Cuneo • Coin • Wedge
06 07 141	G 10/1	Distanziale • Entretoise • Spacer	06 15 068	S 202/5	Giunto • Joint • Joint	12 01 050	A 10/5	Registro • Regulateur • Adjuster ass'y
06 07 141	G 10/5	Distanziale • Entretoise • Spacer	06 15 069	S 202/5	Giunto • Joint • Joint	12 01 134	A 10/5	Traversa • Traverse • Cross member
06 07 141	H 30/5	Distanziale • Entretoise • Spacer	06 16 025	N 20/5	Dente • Dent • Tooth			
06 07 142	F 10/4	Distanziale • Entretoise • Spacer	06 16 048	N 20/5	Perno • Pivot • Pin			
06 07 142	F 10/5	Distanziale • Entretoise • Spacer	06 16 133	N 20/5	Tirante • Tirant • Tie rod			
06 07 142	G 10/1	Distanziale • Entretoise • Spacer	06 16 194	N 10/3	Perno • Pivot • Pin			
06 07 142	G 10/5	Distanziale • Entretoise • Spacer	06 16 197	N 10/3	Perno • Pivot • Pin			
06 07 263	G 40/5	Forcella • Fourche • Fork	06 16 197	N 10/5	Perno • Pivot • Pin			

Codice Code	Tav. Tab.	Descrizione • Description • Description	Codice Code	Tav. Tab.	Descrizione • Description • Description	Codice Code	Tav. Tab.	Descrizione • Description • Description
12 01 134	A 10/5	Traversa • Traverse • Cross member	15 20 066	S 120/5	Supporto • Support • Support	19 09 418	L 20/1	Anello • Bague • Ring
12 01 168	S 200/5	Attacco • Connexion • Connection	15 20 102	S 140/5	Staffa • Bride • Bracket	19 09 418	L 20/1	Anello • Bague • Ring
12 01 194	S 200/5	Attacco • Connexion • Connection	15 46 002	S 70/5	Deflettore per foraggi corti • Deflecteur pour fourrages courts Baffle plate for schort crops	19 17 068	P 40/5	Squadro • Equerre • Square
12 02 006	B 30/5	Supporto • Support • Support	16 02 050	B 10/5	Pignone • Pignon • Pinion	19 20 018	S 100/5	Staffa • Bride • Bracket
12 02 008	B 10/5	Perno • Pivot • Pin	16 09 002	E 50/4	Albero cardanico • Arbre à cardan • Cardan shaft	19 20 018	S 180/5	Staffa • Bride • Bracket
12 02 008	B 10/5	Perno • Pivot • Pin	16 09 002	E 50/4	Giunto • Joint • Joint	19 20 018	S 70/5	Staffa • Bride • Bracket
12 02 008	B 20/5	Perno • Pivot • Pin	16 09 003	E 50/4	Giunto • Joint • Joint	19 20 023	S 170/5	Cursore • Curseur • Cursor
12 02 008	H 20/5	Perno • Pivot • Pin	16 09 003	E 50/4	Giunto • Joint • Joint	19 20 047	S 160/5	Guida • Guide • Guide
12 02 008	H 30/5	Perno • Pivot • Pin	16 09 004	E 50/4	Giunto • Joint • Joint	19 20 048	S 160/5	Perno • Pivot • Pin
12 02 010	B 30/5	Perno • Pivot • Pin	16 09 004	E 50/4	Giunto • Joint • Joint	19 20 049	S 160/5	Perno • Pivot • Pin
12 02 011	B 30/5	Manicotto • Manchon • Sleeve	16 09 005	E 50/4	Protezione • Protection • Guard	19 20 050	S 160/5	Perno • Pivot • Pin
12 02 012	B 30/5	Dente • Dent • Tooth	16 15 003	E 50/5	Albero cardanico • Arbre à cardan • Cardan shaft	19 20 051	S 160/5	Supporto • Support • Support
12 02 015	B 10/5	Registro • Regulateur • Adjuster ass'y	16 16 005	N 20/5	Indice • Index • Pointer	19 20 052	S 160/5	Supporto • Support • Support
12 02 043	B 20/5	Perno • Pivot • Pin	16 16 018	N 40/5	Perno • Pivot • Pin	19 20 052	S 210/3	Supporto • Support • Support
12 02 050	B 20/5	Pignone • Pignon • Pinion	16 16 019	N 10/5	Perno • Pivot • Pin	19 20 052	S 210/5	Supporto • Support • Support
12 02 107	B 10/5	Pignone • Pignon • Pinion	16 16 020	N 10/5	Supporto • Support • Support	19 21 001	S 190/4	Staffa • Bride • Bracket
12 02 107	H 30/5	Pignone • Pignon • Pinion	16 16 021	N 10/5	Asta • Tige • Rod	19 21 001	S 190/4	Staffa • Bride • Bracket
12 02 107	N 20/1	Pignone • Pignon • Pinion	16 16 024	N 10/5	Porta aghi • Porte aiguilles • Needles support	19 21 001	S 190/5	Staffa • Bride • Bracket
12 05 001	E 20/5	Tubo • Tuyau • Hose	16 20 010	N 30/5	Leva • Levier • Lever	19 21 001	S 190/5	Staffa • Bride • Bracket
12 05 009	E 20/5	Distanziale • Entretoise • Spacer	16 20 016	S 200/5	Attacco • Connexion • Connection	19 21 002	S 190/4	Staffa • Bride • Bracket
12 05 029	E 20/5	Distanziale • Entretoise • Spacer	16 44 002	E 40/5	Cricchetto • Clef • Ratchet spanner	19 21 002	S 190/5	Staffa • Bride • Bracket
12 05 045	E 40/5	Guidafune • Guide-corde • Rope guide	16 44 024	A 51/5	Ruota • Roue • Wheel	19 21 003	S 190/4	Cavo • Cable • Cable
12 05 148	E 10/5	Protezione • Protection • Guard	19 01 008	S 200/5	Protezione • Protection • Guard	19 21 003	S 190/4	Cavo • Cable • Cable
12 06 008	F 10/4	Albero • Arbre • Shaft	19 01 059	A 30/5	Supporto • Support • Support	19 21 004	S 190/4	Prolunga • Rallonge • Extension
12 06 008	F 10/5	Albero • Arbre • Shaft	19 01 070	A 20/5	Madre vite • Vis • Nut-screw	19 21 004	S 190/5	Prolunga • Rallonge • Extension
12 07 008	G 10/5	Albero • Arbre • Shaft	19 01 073	S 200/5	Vite • Vis • Screw	23 05 001	E 20/5	Albero • Arbre • Shaft
12 07 042	G 10/1	Distanziale • Entretoise • Spacer	19 01 074	A 20/5	Catenaccio • Verrou • Lock	23 05 011	E 20/5	Tubo • Tuyau • Hose
12 07 042	G 10/5	Distanziale • Entretoise • Spacer	19 01 075	S 200/5	Supporto • Support • Support	24 01 030	A 10/5	Distanziale • Entretoise • Spacer
12 08 069	B 10/5	Distanziale • Entretoise • Spacer	19 01 077	S 200/5	Perno • Pivot • Pin	24 01 030	N 40/5	Distanziale • Entretoise • Spacer
12 09 080	E 50/4	Albero cardanico • Arbre à cardan • Cardan shaft	19 01 272	A 20/5	Piastra • Plaque • Plate	24 01 040	A 10/5	Piatto • Plateau • Plate
12 09 092	E 50/4	Protezione • Protection • Guard	19 01 277	A 20/5	Perno • Pivot • Pin	24 01 045	A 50/4	Perno • Pivot • Pin
12 16 003	A 10/5	Rinforzo • Renforcement • Reinforcement	19 05 017	E 10/5	Piastra • Plaque • Plate	24 01 045	A 50/5	Perno • Pivot • Pin
12 16 016	N 20/5	Supporto • Support • Support	19 05 059	E 10/5	Snodo • Articulation • Articulation	24 01 045	A 51/4	Perno • Pivot • Pin
12 16 077	A 10/5	Rinforzo • Renforcement • Reinforcement	19 05 060	E 10/5	Asta • Tige • Rod	24 01 045	A 51/5	Perno • Pivot • Pin
12 16 078	A 10/5	Attacco • Connexion • Connection	19 05 061	E 10/5	Attacco • Connexion • Connection	24 01 047	A 10/5	Camera • Chambre • Chamber
12 16 096	N 10/3	Asta • Tige • Rod	19 05 070	S 160/5	Distanziale • Entretoise • Spacer	24 01 051	A 20/5	Timone • Gouvernal • Drawbar
12 20 064	N 30/5	Supporto • Support • Support	19 05 205	E 20/5	Camma • Came • Cam	24 01 055	A 20/5	Perno • Pivot • Pin
12 46 001	S 50/5	Coppia di ruote • Paire de roues • Couple of wheels	19 05 222	E 20/5	Perno • Pivot • Pin	24 01 056	A 20/5	Catenaccio • Verrou • Lock
14 07 138	G 10/1	Albero • Arbre • Shaft	19 06 043	F 20/1	Appoggio • Appui • Support	24 01 057	A 20/5	Rullo • Galet • Roller
14 07 138	G 10/5	Albero • Arbre • Shaft	19 06 043	F 20/5	Appoggio • Appui • Support	24 01 059	A 20/5	Perno • Pivot • Pin
14 07 139	G 10/1	Albero • Arbre • Shaft	19 07 002	G 30/5	Guida • Guide • Guide	24 01 062	A 40/5	Cuneo • Coin • Wedge
14 07 139	G 10/5	Albero • Arbre • Shaft	19 08 119	P 60/5	Angolare • Corniere • Angle piece	24 01 062	R 10/5	Cuneo • Coin • Wedge
14 07 179	G 20/5	Asta • Tige • Rod	19 08 120	P 60/5	Angolare • Corniere • Angle piece	24 01 063	A 40/5	Martelletto • Marteau • Arm
14 16 040	N 10/3	Portaghi • Porte aiguilles • Needles support	19 08 120	P 60/5	Angolare • Corniere • Angle piece	24 01 063	A 40/5	Martelletto • Marteau • Arm
15 07 192	G 30/5	Piastra • Plaque • Plate	19 09 085	E 50/4	Giunto cardanico • Joint cardan • Universal joint	24 01 064	A 40/5	Martelletto • Marteau • Arm
15 20 004	S 140/5	Perno • Pivot • Pin	19 09 086	E 50/4	Giunto cardanico • Joint cardan • Universal joint	24 01 065	A 40/5	Perno • Pivot • Pin
15 20 005	S 140/5	Slitta • Glissiere • Skid	19 09 404	L 20/1	Disco • Disque • Disk	24 01 065	A 40/5	Perno • Pivot • Pin
15 20 013	S 140/5	Braccio • Bras • Arm	19 09 405	L 20/1	Mozzo • Moyeu • Hub	24 01 067	A 20/5	Perno • Pivot • Pin
15 20 017	S 70/5	Deflettore • Deflecteur • Deflector	19 09 418	L 20/1	Anello • Bague • Ring	24 01 070	A 30/5	Assale • Pont • Axle

Codice Code	Tav. Tab.	Descrizione • Description • Description	Codice Code	Tav. Tab.	Descrizione • Description • Description	Codice Code	Tav. Tab.	Descrizione • Description • Description
24 01 070	A 30/5	Assale • Pont • Axle	24 02 124	B 20/5	Distanziale • Entretoise • Spacer	24 04 011	D 10/5	Scatola • Boite • Housing
24 01 071	A 30/5	Assale • Pont • Axle	24 02 132	B 10/5	Ingranaggio • Engrenage • Gear	24 04 020	D 10/5	Anello • Bague • Ring
24 01 072	A 30/5	Supporto • Support • Support	24 03 008	C 10/5	Supporto • Support • Support	24 04 023	D 10/5	Fermo • Arrêt • Retainer
24 01 073	A 20/5	Settore • Tirant • Section	24 03 009	C 10/5	Chiusura • Fermeture • Lock	24 04 031	D 11/4	Volano • Volant • Flywheel
24 01 074	A 30/5	Assale • Pont • Axle	24 03 011	C 10/5	Raschietto • Racloir • Scraper	24 04 033	D 11/4	Braccio • Bras • Arm
24 01 075	A 30/5	Assale • Pont • Axle	24 03 017	C 10/5	Spessore • Epaisseur • Shim	24 04 033	D 11/5	Braccio • Bras • Arm
24 01 075	A 30/5	Assale • Pont • Axle	24 03 021	C 10/5	Lamiera • Tôle • Plate	24 04 036	D 11/4	Rondella • Rondelle • Washer
24 01 076	A 30/5	Assale • Pont • Axle	24 03 024	C 10/5	Perno • Pivot • Pin	24 04 036	D 11/5	Rondella • Rondelle • Washer
24 01 077	A 30/5	Assale • Pont • Axle	24 03 025	C 10/5	Biella • Bielle • Connecting rod	24 04 038	D 10/5	Coperchio • Couvercle • Cover
24 01 082	A 20/5	Perno • Pivot • Pin	24 03 040	C 20/5	Guida • Guide • Guide	24 04 039	D 10/5	Albero • Arbre • Shaft
24 01 083	A 30/5	Supporto • Support • Support	24 03 041	C 20/5	Slitta • Glissiere • Skid	24 04 041	D 10/5	Coppia conica • Couple conique • Bevel gear set
24 01 085	A 30/5	Assale • Pont • Axle	24 03 046	C 20/5	Slitta • Glissiere • Skid	24 04 045	D 10/5	Scatola • Boite • Housing
24 01 095	A 30/5	Assale • Pont • Axle	24 03 048	C 20/5	Guida • Guide • Guide	24 04 050	D 11/5	Volano • Volant • Flywheel
24 01 097	A 30/5	Assale • Pont • Axle	24 03 049	C 20/5	Guida • Guide • Guide	24 04 103	D 10/5	Mozzo • Moyeu • Hub
24 01 109	A 10/5	Telaio • Chassis • Frame	24 03 050	C 20/5	Guida • Guide • Guide	24 04 113	D 10/5	Coperchio • Couvercle • Cover
24 01 124	A 10/5	Fiancata • Cote • Side	24 03 059	C 10/5	Guida • Guide • Guide	24 04 121	D 10/5	Manicotto • Manchon • Sleeve
24 01 125	A 10/5	Fiancata • Cote • Side	24 03 063	C 10/5	Guida • Guide • Guide	24 04 128	D 10/5	Manicotto • Manchon • Sleeve
24 01 127	A 40/5	Listello • Plaque • Plate	24 03 075	C 20/5	Spessore • Epaisseur • Shim	24 04 140	D 10/5	Pignone-corona • Pignon-cauronne • Pinion-crown
24 01 127	A 40/5	Listello • Plaque • Plate	24 03 076	C 20/5	Spessore • Epaisseur • Shim	24 05 030	E 30/5	Supporto • Support • Support
24 01 127	A 40/5	Listello • Plaque • Plate	24 03 077	C 20/5	Spessore • Epaisseur • Shim	24 05 031	E 10/5	Telaio • Chassis • Frame
24 01 127	A 40/5	Listello • Plaque • Plate	24 03 081	C 10/5	Spessore • Epaisseur • Shim	24 05 032	E 10/5	Telaio • Chassis • Frame
24 01 129	A 10/5	Fiancata • Cote • Side	24 03 082	C 10/5	Spessore • Epaisseur • Shim	24 05 033	E 30/5	Distanziale • Entretoise • Spacer
24 01 130	A 10/5	Fiancata • Cote • Side	24 03 083	C 10/5	Spessore • Epaisseur • Shim	24 05 034	E 10/5	Deflettore • Deflecteur • Deflector
24 01 135	A 10/5	Pressaballe • Presseur soudé • Bale density adjuster	24 03 109	C 10/5	Piatto • Plateau • Plate	24 05 035	E 10/5	Supporto • Support • Support
24 01 138	A 10/5	Pressaballe • Presseur soudé • Bale density adjuster	24 03 110	C 10/5	Pistone • Piston • Piston	24 05 036	E 10/5	Supporto • Support • Support
24 01 156	A 30/5	Assale • Pont • Axle	24 03 111	C 10/5	Protezione • Protection • Guard	24 05 037	E 10/5	Deflettore • Deflecteur • Deflector
24 01 158	A 30/5	Assale • Pont • Axle	24 03 112	C 10/5	Raschietto • Racloir • Scraper	24 05 038	E 10/5	Fiancata • Cote • Side
24 01 159	A 20/5	Perno • Pivot • Pin	24 03 115	C 10/5	Manovella • Manivelle • Crank	24 05 039	E 10/5	Fiancata • Cote • Side
24 01 160	A 20/5	Supporto • Support • Support	24 03 120	C 20/5	Coltello • Couteau • Knife	24 05 040	E 10/5	Rinforzo • Renforcement • Reinforcement
24 01 163	A 30/5	Assale • Pont • Axle	24 03 121	C 10/5	Coltello • Couteau • Knife	24 05 043	E 10/5	Braccio • Bras • Arm
24 01 163	A 30/5	Assale • Pont • Axle	24 03 136	C 10/5	Perno • Pivot • Pin	24 05 044	E 10/5	Chiusura • Fermeture • Lock
24 01 164	A 30/5	Assale • Pont • Axle	24 03 137	C 10/5	Rondella • Rondelle • Washer	24 05 047	E 10/5	Protezione • Protection • Guard
24 01 165	A 30/5	Assale • Pont • Axle	24 03 142	C 20/5	Guida • Guide • Guide	24 05 090	E 10/5	Fiancata • Cote • Side
24 01 166	A 20/5	Timone • Gouvernal • Drawbar	24 03 143	C 20/5	Guida • Guide • Guide	24 05 091	E 10/5	Prolunga • Rallonge • Extension
24 01 167	A 20/5	Attacco • Connexion • Connection	24 03 144	C 20/5	Guida • Guide • Guide	24 05 092	E 10/5	Cerniera • Charniere • Hinge
24 01 168	A 30/5	Assale • Pont • Axle	24 03 145	C 20/5	Guida • Guide • Guide	24 05 093	E 10/5	Braccio • Bras • Arm
24 01 195	A 20/5	Supporto • Support • Support	24 03 146	C 20/5	Spessore • Epaisseur • Shim	24 05 094	E 10/5	Supporto • Support • Support
24 02 003	B 10/5	Perno • Pivot • Pin	24 03 147	C 20/5	Guida • Guide • Guide	24 05 095	E 10/5	Chiusura • Fermeture • Lock
24 02 003	N 20/1	Perno • Pivot • Pin	24 03 148	C 20/5	Registro • Regulateur • Adjuster ass'y	24 05 105	E 10/5	Telaio • Chassis • Frame
24 02 004	B 20/5	Piastra • Plaque • Plate	24 03 150	C 10/5	Perno • Pivot • Pin	24 05 105	E 20/5	Telaio • Chassis • Frame
24 02 004	H 20/5	Piastra • Plaque • Plate	24 03 151	C 10/5	Supporto • Support • Support	24 05 107	E 20/5	Tube • Tuyau • Hose
24 02 005	B 10/5	Pignone • Pignon • Pinion	24 03 153	C 20/5	Spessore • Epaisseur • Shim	24 05 108	E 10/5	Deflettore • Deflecteur • Deflector
24 02 005	H 30/5	Pignone • Pignon • Pinion	24 03 154	C 20/5	Spessore • Epaisseur • Shim	24 05 120	E 10/5	Telaio • Chassis • Frame
24 02 017	B 30/5	Separatore • Separateur • Separator	24 03 155	C 20/5	Spessore • Epaisseur • Shim	24 05 121	E 20/5	Tube • Tuyau • Hose
24 02 033	B 10/5	Contralbero • Contre-arbre • Countershaft	24 03 156	C 20/5	Spessore • Epaisseur • Shim	24 05 122	E 20/5	Tube • Tuyau • Hose
24 02 101	B 10/5	Pignone • Pignon • Pinion	24 03 157	C 20/5	Spessore • Epaisseur • Shim	24 05 123	E 10/5	Deflettore • Deflecteur • Deflector
24 02 109	B 30/5	Puleggia • Poulie • Pulley	24 03 158	C 20/5	Spessore • Epaisseur • Shim	24 05 152	E 30/5	Vite • Vis • Screw
24 02 122	B 10/5	Puleggia • Poulie • Pulley	24 04 007	D 10/5	Coperchio • Couvercle • Cover	24 05 153	E 30/5	Perno • Pivot • Pin
24 02 123	B 10/5	Perno • Pivot • Pin	24 04 010	D 10/5	Mozzo • Moyeu • Hub	24 05 154	E 30/5	Molla • Ressort • Spring

Codice Code	Tav. Tab.	Descrizione • Description • Description	Codice Code	Tav. Tab.	Descrizione • Description • Description	Codice Code	Tav. Tab.	Descrizione • Description • Description
24 06 005	F 20/1	Rinforzo • Renforcement • Reinforcement	24 07 017	G 50/5	Protezione • Protection • Guard	24 08 094	H 20/5	Perno • Pivot • Pin
24 06 008	F 10/1	Albero • Arbre • Shaft	24 07 018	G 40/5	Puntone • Etaï • Strut	24 08 095	H 30/5	Ingranaggio • Engrenage • Gear
24 06 009	N 20/1	Distanziale • Entretoise • Spacer	24 07 019	G 30/5	Supporto • Support • Support	24 08 096	H 10/3	Sponda • Planche • Side
24 06 010	F 30/5	Supporto • Support • Support	24 08 018	H 30/5	Mozzo • Moyeu • Hub	24 08 097	H 10/3	Sponda • Planche • Side
24 06 011	F 40/5	Protezione • Protection • Guard	24 08 023	H 20/5	Distanziale • Entretoise • Spacer	24 08 098	H 10/3	Sponda • Planche • Side
24 06 012	F 40/5	Staffa • Bride • Bracket	24 08 025	H 20/5	Albero • Arbre • Shaft	24 08 100	H 10/5	Supporto • Support • Support
24 06 012	G 50/5	Staffa • Bride • Bracket	24 08 030	H 30/5	Albero • Arbre • Shaft	24 08 112	P 30/5	Triangolo • Triangle • Triangle
24 06 013	F 40/5	Staffa • Bride • Bracket	24 08 034	H 20/5	Supporto • Support • Support	24 08 113	P 60/5	Lamiera • Tôle • Plate
24 06 013	F 40/5	Staffa • Bride • Bracket	24 08 036	H 20/5	Dente • Dent • Tooth	24 08 114	P 40/5	Orecchietta • Oreille • Bracket
24 06 013	G 50/5	Staffa • Bride • Bracket	24 08 037	H 20/5	Forca • Fourche • Fork	24 08 122	P 30/5	Rinforzo • Renforcement • Reinforcement
24 06 013	G 50/5	Staffa • Bride • Bracket	24 08 038	H 20/5	Forca • Fourche • Fork	24 08 124	H 20/5	Distanziale • Entretoise • Spacer
24 06 014	F 40/5	Staffa • Bride • Bracket	24 08 041	H 30/5	Dente • Dent • Tooth	24 08 126	H 20/5	Ingranaggio • Engrenage • Gear
24 06 014	F 40/5	Staffa • Bride • Bracket	24 08 041	H 30/5	Dente • Dent • Tooth	24 08 127	P 40/5	Fiancata • Cote • Side
24 06 014	G 50/5	Staffa • Bride • Bracket	24 08 041	H 30/5	Dente • Dent • Tooth	24 08 128	P 40/5	Fiancata • Cote • Side
24 06 014	G 50/5	Staffa • Bride • Bracket	24 08 042	H 30/5	Braccio • Bras • Arm	24 08 129	P 60/5	Sponda • Planche • Side
24 06 015	F 30/5	Divisore • Diviseur • Flow divider	24 08 045	H 30/5	Forca • Fourche • Fork	24 08 130	P 60/5	Sponda • Planche • Side
24 06 016	F 30/5	Supporto • Support • Support	24 08 048	H 10/3	Sponda • Planche • Side	24 08 131	P 10/5	Staffa • Bride • Bracket
24 06 017	F 30/5	Supporto • Support • Support	24 08 049	P 60/5	Sponda • Planche • Side	24 08 131	P 11/5	Staffa • Bride • Bracket
24 06 018	F 20/5	Rinforzo • Renforcement • Reinforcement	24 08 050	P 60/5	Sponda • Planche • Side	24 08 132	H 30/5	Braccio • Bras • Arm
24 06 019	F 40/5	Protezione • Protection • Guard	24 08 055	H 30/5	Tirante • Tirant • Tie rod	24 08 133	H 30/5	Forca • Fourche • Fork
24 06 020	F 40/5	Staffa • Bride • Bracket	24 08 060	H 10/3	Sponda • Planche • Side	24 08 135	P 30/5	Piano • Plan • Table
24 06 020	G 50/5	Staffa • Bride • Bracket	24 08 061	H 10/3	Sponda • Planche • Side	24 08 136	P 60/5	Portello • Porte • Door
24 06 021	F 30/5	Asta • Tige • Rod	24 08 065	H 10/3	Guida • Guide • Guide	24 08 137	H 10/5	Invito • Guide • Guide
24 06 022	F 30/5	Supporto • Support • Support	24 08 065	H 10/5	Guida • Guide • Guide	24 08 138	H 10/3	Distanziale • Entretoise • Spacer
24 06 029	F 20/1	Coppiglia • Goupille • Cotter pin	24 08 066	H 10/3	Guida • Guide • Guide	24 08 138	H 10/5	Distanziale • Entretoise • Spacer
24 06 049	F 30/5	Supporto • Support • Support	24 08 066	H 10/5	Guida • Guide • Guide	24 08 139	H 20/5	Braccio • Bras • Arm
24 06 050	F 40/5	Fascia • Collier • Clamping ring	24 08 069	H 30/5	Distanziale • Entretoise • Spacer	24 08 140	H 20/5	Braccio • Bras • Arm
24 06 051	F 40/5	Chiusura • Fermeture • Lock	24 08 071	H 20/5	Testa • Tete • Head	24 08 180	H 10/3	Guida • Guide • Guide
24 06 052	F 40/5	Staffa • Bride • Bracket	24 08 072	H 20/5	Perno • Pivot • Pin	24 08 180	H 10/5	Guida • Guide • Guide
24 06 053	F 40/5	Staffa • Bride • Bracket	24 08 073	H 20/5	Tenditore • Tendeur • Tightener	24 08 181	H 30/5	Forca • Fourche • Fork
24 06 053	G 50/5	Staffa • Bride • Bracket	24 08 074	H 20/5	Snodo • Articulation • Articulation	24 08 183	H 30/5	Albero • Arbre • Shaft
24 06 150	N 20/5	Staffa • Bride • Bracket	24 08 076	P 30/5	Lamiera • Tôle • Plate	24 08 184	H 30/5	Dente • Dent • Tooth
24 07 001	G 10/1	Albero • Arbre • Shaft	24 08 077	P 30/5	Piano • Plan • Table	24 08 185	H 30/5	Albero • Arbre • Shaft
24 07 002	G 10/1	Albero • Arbre • Shaft	24 08 078	P 30/5	Piano • Plan • Table	24 08 186	H 10/3	Guida • Guide • Guide
24 07 002	G 10/5	Albero • Arbre • Shaft	24 08 079	P 30/5	Fiancata • Cote • Side	24 08 186	H 10/5	Guida • Guide • Guide
24 07 003	G 10/1	Staffa • Bride • Bracket	24 08 080	P 11/5	Supporto • Support • Support	24 08 187	P 60/5	Lamiera • Tôle • Plate
24 07 004	G 30/5	Traversa • Traverse • Cross member	24 08 081	P 40/5	Fiancata • Cote • Side	24 08 188	P 30/5	Piano • Plan • Table
24 07 005	G 20/5	Albero • Arbre • Shaft	24 08 082	P 40/5	Fiancata sinistra • Cote gauche • Left side	24 08 189	H 10/3	Sponda • Planche • Side
24 07 006	G 10/1	Camma • Came • Cam	24 08 083	P 60/5	Sponda • Planche • Side	24 08 190	P 60/5	Sponda • Planche • Side
24 07 007	G 10/1	Piastrina • Plaquette • Plate	24 08 084	P 60/5	Sponda • Planche • Side	24 08 191	P 30/5	Lamiera • Tôle • Plate
24 07 008	G 20/5	Rinforzo • Renforcement • Reinforcement	24 08 085	H 30/5	Flangia • Flasque • Flange	24 08 192	P 30/5	Chiusura • Fermeture • Lock
24 07 009	G 40/5	Puntone • Etaï • Strut	24 08 086	H 30/5	Staffa • Bride • Bracket	24 08 193	P 30/5	Piano • Plan • Table
24 07 010	G 40/5	Puntone • Etaï • Strut	24 08 087	H 20/5	Braccio • Bras • Arm	24 08 194	P 30/5	Piano • Plan • Table
24 07 011	G 50/5	Fascia • Collier • Clamping ring	24 08 088	H 20/5	Braccio • Bras • Arm	24 08 195	P 30/5	Piano • Plan • Table
24 07 012	G 50/5	Chiusura • Fermeture • Lock	24 08 089	H 20/5	Camma • Came • Cam	24 08 196	P 30/5	Piano • Plan • Table
24 07 013	G 50/5	Protezione • Protection • Guard	24 08 090	H 20/5	Rullo • Galet • Roller	24 08 213	P 60/5	Portello • Porte • Door
24 07 014	G 50/5	Chiusura • Fermeture • Lock	24 08 091	H 20/5	Distanziale • Entretoise • Spacer	24 08 222	H 10/5	Sponda • Planche • Side
24 07 015	P 60/5	Squadro • Equerre • Square	24 08 092	H 20/5	Guida • Guide • Guide	24 08 223	H 10/5	Sponda • Planche • Side
24 07 016	G 20/5	Rinforzo • Renforcement • Reinforcement	24 08 093	H 20/5	Snodo • Articulation • Articulation	24 08 224	H 10/5	Sponda • Planche • Side

Codice Code	Tav. Tab.	Descrizione • Description • Description	Codice Code	Tav. Tab.	Descrizione • Description • Description	Codice Code	Tav. Tab.	Descrizione • Description • Description
24 08 225	H 30/5	Braccio • Bras • Arm	24 16 005	N 20/1	Camma • Came • Cam	24 17 013	P 50/5	Rinforzo • Renforcement • Reinforcement
24 08 226	H 10/5	Sponda • Planche • Side	24 16 006	N 20/1	Supporto • Support • Support	24 17 035	P 11/5	Protezione • Protection • Guard
24 08 227	H 10/5	Distanziale • Entretoise • Spacer	24 16 007	N 20/1	Braccio • Bras • Arm	24 17 036	P 11/5	Protezione • Protection • Guard
24 09 001	L 10/3	Giunto • Joint • Joint	24 16 008	N 30/5	Braccio • Bras • Arm	24 17 037	P 11/5	Protezione • Protection • Guard
24 09 002	L 10/3	Giunto • Joint • Joint	24 16 009	N 30/5	Riscontro • Repere • Striker	24 17 038	P 11/5	Protezione • Protection • Guard
24 09 003	L 10/3	Giunto • Joint • Joint	24 16 011	N 20/1	Perno • Pivot • Pin	24 17 039	P 11/5	Protezione • Protection • Guard
24 09 004	L 20/1	Frizione • Embrayage • Clutch	24 16 011	N 20/5	Perno • Pivot • Pin	24 17 040	P 40/5	Coperchio • Couvercle • Cover
24 09 005	L 10/3	Albero cardanico • Arbre à cardan • Cardan shaft	24 16 012	N 20/1	Perno • Pivot • Pin	24 17 041	P 40/5	Coperchio • Couvercle • Cover
24 09 006	L 10/3	Giunto completo • Joint complet • Coupling, ass'y	24 16 015	N 30/5	Supporto • Support • Support	24 17 042	P 11/5	Protezione • Protection • Guard
24 09 007	L 10/3	Protezione • Protection • Guard	24 16 016	N 20/1	Supporto • Support • Support	24 17 043	P 11/5	Chiusura • Fermeture • Lock
24 09 008	L 10/3	Protezione • Protection • Guard	24 16 020	N 40/5	Supporto • Support • Support	24 17 044	P 11/5	Staffa • Bride • Bracket
24 09 009	L 10/3	Tubo cardanico • Tuyau arbre • Hose shaft	24 16 021	N 40/5	Perno • Pivot • Pin	24 17 045	P 11/5	Staffa • Bride • Bracket
24 09 009	L 10/3	Tubo cardanico • Tuyau arbre • Hose shaft	24 16 025	N 20/1	Dente • Dent • Tooth	24 17 045	P 11/5	Staffa • Bride • Bracket
24 09 010	L 10/3	Tubo cardanico • Tuyau arbre • Hose shaft	24 16 034	N 20/1	Ruota • Roue • Wheel	24 17 047	P 11/5	Supporto • Support • Support
24 09 010	L 10/3	Tubo cardanico • Tuyau arbre • Hose shaft	24 16 035	N 40/5	Dente • Dent • Tooth	24 17 049	P 30/5	Protezione • Protection • Guard
24 09 011	L 10/3	Giunto • Joint • Joint	24 16 041	N 10/1	Porta aghi • Porte aiguilles • Needles support	24 17 052	P 20/5	Chiusura • Fermeture • Lock
24 09 011	L 10/3	Giunto • Joint • Joint	24 16 051	N 40/5	Dente • Dent • Tooth	24 17 053	P 20/5	Fiancata • Cote • Side
24 09 011	L 10/5	Giunto • Joint • Joint	24 16 053	N 40/5	Braccio • Bras • Arm	24 17 054	P 20/5	Fiancata • Cote • Side
24 09 011	L 10/5	Giunto • Joint • Joint	24 16 054	N 40/5	Asta • Tige • Rod	24 17 055	P 20/5	Rinforzo • Renforcement • Reinforcement
24 09 012	L 20/1	Flangia • Flaque • Flange	24 16 055	N 40/5	Supporto • Support • Support	24 17 056	P 20/5	Supporto • Support • Support
24 09 012	L 20/1	Flangia • Flaque • Flange	24 16 056	N 40/5	Leva • Levier • Lever	24 17 057	P 20/5	Supporto • Support • Support
24 09 016	L 20/1	Frizione • Embrayage • Clutch	24 16 057	N 40/5	Perno • Pivot • Pin	24 17 058	P 20/5	Supporto • Support • Support
24 09 017	L 20/1	Frizione • Embrayage • Clutch	24 16 065	N 10/1	Flangia • Flaque • Flange	24 17 059	P 20/5	Guida • Guide • Guide
24 09 018	E 50/4	Albero cardanico • Arbre à cardan • Cardan shaft	24 16 078	N 20/5	Supporto • Support • Support	24 17 061	P 30/5	Protezione • Protection • Guard
24 09 020	L 20/5	Frizione • Embrayage • Clutch	24 16 079	N 40/5	Attacco • Connexion • Connection	24 17 063	P 30/5	Supporto • Support • Support
24 09 021	L 20/5	Anello • Bague • Ring	24 16 080	N 40/5	Leva • Levier • Lever	24 17 063	P 30/5	Supporto • Support • Support
24 09 022	L 20/5	Disco • Disque • Disk	24 16 081	N 40/5	Perno • Pivot • Pin	24 17 064	P 30/5	Supporto • Support • Support
24 09 023	L 20/5	Anello • Bague • Ring	24 16 082	N 40/5	Asta • Tige • Rod	24 17 064	P 30/5	Supporto • Support • Support
24 09 023	L 20/5	Anello • Bague • Ring	24 16 104	N 20/1	Ingranaggio • Engrenage • Gear	24 17 064	P 30/5	Supporto • Support • Support
24 09 025	L 20/5	Albero scanalato • Arbre cannelé • Grooved shaft	24 16 110	N 30/5	Ruota • Roue • Wheel	24 17 067	P 30/5	Protezione • Protection • Guard
24 09 026	L 20/5	Guarnizione • Joint • Seal	24 16 117	N 30/5	Registro • Regulateur • Adjuster ass'y	24 17 068	P 41/5	Protezione • Protection • Guard
24 09 027	L 20/5	Chiavetta • Clè • Key	24 16 118	N 30/5	Supporto • Support • Support	24 17 069	P 41/5	Protezione • Protection • Guard
24 09 027	L 20/5	Chiavetta • Clè • Key	24 16 119	N 30/5	Registro • Regulateur • Adjuster ass'y	24 17 070	P 41/5	Angolare • Corniere • Angle piece
24 09 028	L 20/5	Molla • Ressort • Spring	24 16 119	N 30/5	Registro • Regulateur • Adjuster ass'y	24 17 071	P 41/5	Angolare • Corniere • Angle piece
24 09 028	L 20/5	Molla • Ressort • Spring	24 16 120	N 30/5	Braccio • Bras • Arm	24 17 072	P 41/5	Angolare • Corniere • Angle piece
24 09 029	L 20/5	Disco • Disque • Disk	24 16 121	N 30/5	Braccio • Bras • Arm	24 17 073	P 41/5	Piatto • Plateau • Plate
24 09 030	L 20/5	Anello • Bague • Ring	24 16 128	N 30/5	Perno • Pivot • Pin	24 17 074	P 41/5	Fiancata • Cote • Side
24 09 031	L 20/5	Cassa • Boîte • Casing	24 16 160	N 30/5	Rotella • Galet • Roller	24 17 075	P 41/5	Fiancata • Cote • Side
24 09 201	L 10/3	Giunto • Joint • Joint	24 16 161	N 30/5	Appoggio • Appui • Support	24 17 076	P 40/5	Lamiera • Tôle • Plate
24 09 201	L 10/5	Giunto • Joint • Joint	24 16 163	N 30/5	Supporto • Support • Support	24 17 077	P 40/5	Lamiera • Tôle • Plate
24 11 003	S 210/3	Tubo • Tuyau • Hose	24 16 163	N 30/5	Supporto • Support • Support	24 17 078	P 40/5	Supporto • Support • Support
24 11 003	S 210/3	Tubo • Tuyau • Hose	24 16 164	N 30/5	Boccola • Douille • Bushing	24 17 079	P 41/5	Perno • Pivot • Pin
24 11 003	S 210/5	Tubo • Tuyau • Hose	24 16 164	N 30/5	Boccola • Douille • Bushing	24 17 080	P 30/5	Prolunga • Rallonge • Extension
24 11 003	S 210/5	Tubo • Tuyau • Hose	24 16 173	F 10/1	Supporto • Support • Support	24 17 080	P 30/5	Prolunga • Rallonge • Extension
24 11 005	S 210/5	Supporto • Support • Support	24 16 174	F 30/5	Staffa • Bride • Bracket	24 17 080	P 30/5	Prolunga • Rallonge • Extension
24 15 001	L 11/5	Albero cardanico • Arbre à cardan • Cardan shaft	24 16 196	N 10/1	Asta • Tige • Rod	24 17 081	P 60/5	Fiancata • Cote • Side
24 15 002	L 11/5	Albero cardanico • Arbre à cardan • Cardan shaft	24 16 199	N 10/1	Snodo • Articulation • Articulation	24 17 082	P 60/5	Piano • Plan • Table
24 16 001	A 10/5	Protezione • Protection • Guard	24 17 004	P 20/5	Piatto • Plateau • Plate	24 17 083	H 10/3	Angolare • Corniere • Angle piece
24 16 002	A 10/5	Protezione • Protection • Guard	24 17 013	P 50/5	Rinforzo • Renforcement • Reinforcement	24 17 083	H 10/5	Angolare • Corniere • Angle piece

Codice Code	Tav. Tab.	Descrizione • Description • Description	Codice Code	Tav. Tab.	Descrizione • Description • Description	Codice Code	Tav. Tab.	Descrizione • Description • Description
24 17 084	P 60/5	Fiancata • Cote • Side	24 17 159	P 10/5	Protezione • Protection • Guard	24 20 053	S 130/5	Piastra • Plaque • Plate
24 17 085	P 50/5	Supporto • Support • Support	24 17 160	P 10/5	Chiusura • Fermeture • Lock	24 20 058	S 200/5	Timone • Gouvenal • Drawbar
24 17 086	P 50/5	Rinforzo • Renforcement • Reinforcement	24 17 162	P 60/5	Chiusura • Fermeture • Lock	24 20 087	S 160/5	Staffa • Bride • Bracket
24 17 087	P 50/5	Attacco • Connexion • Connection	24 17 168	P 10/5	Protezione • Protection • Guard	24 20 087	S 170/5	Staffa • Bride • Bracket
24 17 087	P 50/5	Attacco • Connexion • Connection	24 17 169	P 10/5	Protezione • Protection • Guard	24 20 087	S 170/5	Staffa • Bride • Bracket
24 17 088	P 50/5	Rinforzo • Renforcement • Reinforcement	24 17 170	P 10/5	Protezione • Protection • Guard	24 20 087	S 90/5	Staffa • Bride • Bracket
24 17 089	P 50/5	Staffa • Bride • Bracket	24 17 173	P 10/5	Staffa • Bride • Bracket	24 20 156	H 10/5	Piastra • Plaque • Plate
24 17 090	P 40/5	Protezione • Protection • Guard	24 17 174	P 10/5	Staffa • Bride • Bracket	24 20 160	S 170/5	Supporto • Support • Support
24 17 091	P 50/5	Rinforzo • Renforcement • Reinforcement	24 17 176	P 10/5	Staffa • Bride • Bracket	24 20 161	S 170/5	Fermo • Arrêt • Retainer
24 17 092	P 50/5	Asta • Tige • Rod	24 17 179	P 10/5	Protezione • Protection • Guard	24 20 162	S 170/5	Asta • Tige • Rod
24 17 092	P 50/5	Asta • Tige • Rod	24 17 180	P 10/5	Staffa • Bride • Bracket	24 20 167	S 180/5	Deflettore • Deflecteur • Deflector
24 17 093	P 50/5	Protezione • Protection • Guard	24 17 181	P 10/5	Supporto • Support • Support	24 20 175	S 90/5	Supporto • Support • Support
24 17 094	P 50/5	Protezione • Protection • Guard	24 17 182	P 60/5	Appoggio • Appui • Support	24 20 176	S 210/3	Supporto • Support • Support
24 17 095	P 50/5	Rinforzo • Renforcement • Reinforcement	24 17 183	P 20/5	Protezione • Protection • Guard	24 20 177	S 90/5	Piatto • Plateau • Plate
24 17 096	P 50/5	Rinforzo • Renforcement • Reinforcement	24 17 184	P 40/5	Lamiera • Tôle • Plate	24 20 179	S 210/5	Supporto • Support • Support
24 17 097	P 50/5	Protezione • Protection • Guard	24 17 185	P 50/5	Coperchio • Couvercle • Cover	24 20 179	S 210/5	Supporto • Support • Support
24 17 098	P 11/5	Staffa • Bride • Bracket	24 17 186	P 60/5	Piano • Plan • Table	24 20 186	S 90/5	Supporto • Support • Support
24 17 103	P 40/5	Protezione • Protection • Guard	24 17 187	P 50/5	Rinforzo • Renforcement • Reinforcement	24 20 269	A 20/5	Attacco • Connexion • Connection
24 17 107	P 20/5	Supporto • Support • Support	24 17 188	P 30/5	Protezione • Protection • Guard	24 21 001	S 190/4	Cavo • Cable • Cable
24 17 108	P 20/5	Fascia • Collier • Clamping ring	24 17 189	P 30/5	Protezione • Protection • Guard	24 21 001	S 190/4	Cavo • Cable • Cable
24 17 109	P 20/5	Fiancata • Cote • Side	24 17 190	P 60/5	Piano • Plan • Table	24 21 002	R 10/5	Supporto • Support • Support
24 17 113	P 20/5	Fiancata • Cote • Side	24 17 191	P 50/5	Protezione • Protection • Guard	24 21 003	S 190/5	Cavo • Cable • Cable
24 17 122	A 10/5	Lamiera • Tôle • Plate	24 17 192	P 40/5	Coperchio • Couvercle • Cover	24 21 003	S 190/5	Cavo • Cable • Cable
24 17 123	A 10/5	Protezione • Protection • Guard	24 17 193	P 41/5	Protezione • Protection • Guard	24 21 003	S 190/5	Cavo • Cable • Cable
24 17 125	B 30/5	Protezione • Protection • Guard	24 17 194	P 41/5	Angolare • Corniere • Angle piece	24 21 003	S 190/5	Cavo • Cable • Cable
24 17 126	B 30/5	Distanziale • Entretoise • Spacer	24 17 195	P 50/5	Rinforzo • Renforcement • Reinforcement	24 21 004	S 190/5	Supporto • Support • Support
24 17 134	P 40/5	Coperchio • Couvercle • Cover	24 17 196	P 40/5	Lamiera • Tôle • Plate	24 21 005	S 190/5	Supporto • Support • Support
24 17 135	P 40/5	Coperchio • Couvercle • Cover	24 17 197	P 41/5	Lamiera • Tôle • Plate	24 44 002	A 50/4	Mozzo • Moyeu • Hub
24 17 136	P 50/5	Staffa • Bride • Bracket	24 17 198	P 41/5	Fiancata • Cote • Side	24 44 002	A 51/4	Mozzo • Moyeu • Hub
24 17 137	P 50/5	Staffa • Bride • Bracket	24 17 198	P 41/5	Fiancata • Cote • Side	24 44 003	A 50/4	Ruota • Roue • Wheel
24 17 138	P 50/5	Coperchio • Couvercle • Cover	24 17 199	P 41/5	Piastra • Plaque • Plate	24 44 003	S 110/4	Ruota • Roue • Wheel
24 17 139	P 50/5	Protezione • Protection • Guard	24 17 200	P 41/5	Lamiera • Tôle • Plate	24 44 004	A 51/4	Ruota • Roue • Wheel
24 17 141	P 50/5	Protezione • Protection • Guard	24 17 201	P 41/5	Protezione • Protection • Guard	24 44 010	N 20/1	Nastro • Ruban • Tape
24 17 142	P 50/5	Rinforzo • Renforcement • Reinforcement	24 17 202	P 41/5	Protezione • Protection • Guard	24 44 012	E 10/5	Raccoglitore completo • Ramasseur complet • Complete pick-up
24 17 143	P 60/5	Protezione • Protection • Guard	24 17 203	P 41/5	Protezione • Protection • Guard	24 44 013	E 10/5	Raccoglitore completo • Ramasseur complet • Complete pick-up
24 17 144	P 40/5	Supporto • Support • Support	24 17 204	P 41/5	Fiancata destra • Cote droite • Right side	24 44 020	N 20/1	Supporto • Support • Support
24 17 145	P 40/5	Lamiera • Tôle • Plate	24 17 205	P 41/5	Fiancata • Cote • Side	24 44 021	N 20/1	Supporto • Support • Support
24 17 145	P 40/5	Lamiera • Tôle • Plate	24 17 206	P 41/5	Piatto • Plateau • Plate	24 44 022	E 10/5	Mozzo completo • Moyeu complet • Complete rotor flange
24 17 146	P 40/5	Lamiera • Tôle • Plate	24 17 212	P 11/5	Protezione • Protection • Guard	24 44 023	E 10/5	Raccoglitore completo • Ramasseur complet • Complete pick-up
24 17 147	P 60/5	Fiancata • Cote • Side	24 17 213	P 11/5	Protezione • Protection • Guard	24 44 024	E 10/5	Raccoglitore completo • Ramasseur complet • Complete pick-up
24 17 148	H 10/5	Protezione • Protection • Guard	24 20 005	S 140/5	Staffa • Bride • Bracket	24 44 028	P 41/5	Protezione completa • Protection complète • Full guard
24 17 149	P 11/5	Protezione • Protection • Guard	24 20 007	N 20/1	Staffa • Bride • Bracket	24 44 029	P 41/5	Protezione completa • Protection complète • Full guard
24 17 152	P 11/5	Staffa • Bride • Bracket	24 20 008	N 30/5	Staffa • Bride • Bracket	24 44 030	P 41/5	Protezione completa • Protection complète • Full guard
24 17 153	P 11/5	Staffa • Bride • Bracket	24 20 014	S 110/4	Mensola • Console • Reinforcement	24 44 037	P 41/5	Protezione • Protection • Guard
24 17 154	P 11/5	Staffa • Bride • Bracket	24 20 014	S 110/5	Mensola • Console • Reinforcement	24 44 038	P 41/5	Protezione • Protection • Guard
24 17 155	P 50/5	Protezione • Protection • Guard	24 20 015	S 160/5	Staffa • Bride • Bracket	24 44 039	E 10/5	Raccoglitore completo • Ramasseur complet • Complete pick-up
24 17 156	P 50/5	Rinforzo • Renforcement • Reinforcement	24 20 016	S 160/5	Attacco • Connexion • Connection	24 44 041	S 90/5	Mozzo completo • Moyeu complet • Complete rotor flange
24 17 157	P 40/5	Carter • Carter • Casing	24 20 017	S 100/5	Deflettore • Deflecteur • Deflector	24 44 042	P 41/5	Protezione completa • Protection complète • Full guard
24 17 158	P 40/5	Carter • Carter • Casing	24 20 025	S 150/5	Prolunga • Rallonge • Extension	24 44 043	P 41/5	Protezione completa • Protection complète • Full guard

Codice Code	Tav. Tab.	Descrizione • Description • Description	Codice Code	Tav. Tab.	Descrizione • Description • Description	Codice Code	Tav. Tab.	Descrizione • Description • Description
32 09 013	S 201/5	Protezione • Protection • Guard	53 09 010	S 201/5	Albero cardanico • Arbre à cardan • Cardan shaft	88 50 065	A 51/5	Vite • Vis • Screw
32 15 031	S 202/5	Perno • Pivot • Pin	53 09 011	S 201/5	Albero cardanico • Arbre à cardan • Cardan shaft	88 50 068	F 30/5	Vite • Vis • Screw
32 15 031	S 202/5	Perno • Pivot • Pin	53 09 012	S 201/5	Giunto • Joint • Joint	88 50 068	G 30/5	Vite • Vis • Screw
32 15 031	S 202/5	Perno • Pivot • Pin	53 09 012	S 201/5	Giunto • Joint • Joint	88 50 074	S 90/5	Vite • Vis • Screw
32 21 014	S 190/5	Fanale • Feu • Light	53 09 012	S 201/5	Giunto • Joint • Joint	88 50 083	S 140/5	Vite • Vis • Screw
34 09 031	L 10/5	Giunto cardanico • Joint cardan • Universal joint	53 09 056	S 201/5	Protezione • Protection • Guard	88 50 089	A 20/5	Vite • Vis • Screw
34 09 037	L 10/5	Crociera completa • Croisillon complet • Complete cross member	53 09 070	S 201/5	Tubo cardanico • Tuyau arbre • Hose shaft	88 50 092	S 130/5	Vite • Vis • Screw
34 15 607	S 202/5	Snodo • Articulation • Articulation	53 09 071	S 201/5	Tubo cardanico • Tuyau arbre • Hose shaft	88 50 095	S 140/5	Vite • Vis • Screw
34 15 607	S 202/5	Snodo • Articulation • Articulation	53 09 072	S 201/5	Tubo cardanico • Tuyau arbre • Hose shaft	88 50 099	A 20/5	Vite • Vis • Screw
34 15 607	S 202/5	Snodo • Articulation • Articulation	53 16 020	N 30/5	Braccio • Bras • Arm	88 50 107	S 200/5	Vite • Vis • Screw
34 15 614	S 202/5	Snodo • Articulation • Articulation	53 17 046	P 11/5	Protezione • Protection • Guard	88 50 110	S 200/5	Vite • Vis • Screw
34 15 620	S 202/5	Protezione • Protection • Guard	53 17 047	P 60/5	Appoggio • Appui • Support	88 50 111	A 20/5	Vite • Vis • Screw
34 20 565	S 130/5	Cerchio • Jante • Rim	53 17 049	P 11/5	Guida • Guide • Guide	88 50 111	S 200/5	Vite • Vis • Screw
35 01 830	A 50/5	Mozzo • Moyeu • Hub	53 17 082	P 20/5	Fermo • Arrêt • Retainer	88 50 115	A 20/5	Vite • Vis • Screw
35 01 830	A 51/5	Mozzo • Moyeu • Hub	53 17 082	P 50/5	Fermo • Arrêt • Retainer	88 50 115	S 150/5	Vite • Vis • Screw
36 04 107	F 10/1	Distanziale • Entretoise • Spacer	53 17 123	P 20/5	Piastra • Plaque • Plate	88 50 115	S 90/5	Vite • Vis • Screw
36 04 107	H 30/5	Distanziale • Entretoise • Spacer	53 20 004	S 30/5	Braccio • Bras • Arm	88 50 135	L 20/1	Vite • Vis • Screw
36 04 107	H 30/5	Distanziale • Entretoise • Spacer	53 20 004	S 30/5	Braccio • Bras • Arm	88 50 150	L 20/1	Vite • Vis • Screw
39 21 008	S 190/5	Fanale • Feu • Light	53 20 005	S 30/5	Albero • Arbre • Shaft	88 50 150	L 20/1	Vite • Vis • Screw
39 21 008	S 190/5	Fanale • Feu • Light	53 20 016	S 170/5	Piastra • Plaque • Plate	88 50 198	F 10/5	Vite • Vis • Screw
40 20 103	N 40/5	Forcella • Fourche • Fork	53 20 075	S 130/5	Braccio • Bras • Arm	88 50 198	S 40/5	Vite • Vis • Screw
40 20 104	N 40/5	Perno • Pivot • Pin	80 80 012	G 10/1	Bronzina • Coussinet • Bushing	88 50 213	C 10/5	Vite • Vis • Screw
43 02 011	G 10/1	Distanziale • Entretoise • Spacer	88 50 014	N 20/5	Vite • Vis • Screw	88 50 213	P 20/5	Vite • Vis • Screw
43 02 013	S 130/5	Distanziale • Entretoise • Spacer	88 50 024	H 30/5	Vite • Vis • Screw	88 50 215	F 30/5	Vite • Vis • Screw
43 20 080	S 210/3	Perno • Pivot • Pin	88 50 024	R 10/5	Vite • Vis • Screw	88 50 215	F 30/5	Vite • Vis • Screw
43 20 080	S 210/3	Perno • Pivot • Pin	88 50 025	P 30/5	Vite • Vis • Screw	88 50 215	N 40/5	Vite • Vis • Screw
43 20 080	S 210/5	Perno • Pivot • Pin	88 50 025	P 50/5	Vite • Vis • Screw	88 50 215	P 20/5	Vite • Vis • Screw
43 20 080	S 210/5	Perno • Pivot • Pin	88 50 027	D 11/4	Vite • Vis • Screw	88 50 215	P 20/5	Vite • Vis • Screw
45 02 016	B 10/5	Ingranaggio • Engrenage • Gear	88 50 027	D 11/5	Vite • Vis • Screw	88 50 215	P 41/5	Vite • Vis • Screw
45 02 016	B 20/5	Ingranaggio • Engrenage • Gear	88 50 027	R 10/5	Vite • Vis • Screw	88 50 215	S 10/4	Vite • Vis • Screw
45 02 016	H 20/5	Ingranaggio • Engrenage • Gear	88 50 033	A 20/5	Vite • Vis • Screw	88 50 215	S 10/5	Vite • Vis • Screw
45 09 469	E 50/4	Tubo cardanico • Tuyau arbre • Hose shaft	88 50 041	N 20/5	Vite • Vis • Screw	88 50 215	S 190/5	Vite • Vis • Screw
45 09 470	E 50/4	Tubo cardanico • Tuyau arbre • Hose shaft	88 50 042	N 30/5	Vite • Vis • Screw	88 50 215	S 20/4	Vite • Vis • Screw
45 17 056	P 40/5	Appoggio • Appui • Support	88 50 042	S 160/5	Vite • Vis • Screw	88 50 215	S 20/5	Vite • Vis • Screw
45 20 032	P 20/5	Distanziale • Entretoise • Spacer	88 50 042	S 170/5	Vite • Vis • Screw	88 50 216	G 10/1	Vite • Vis • Screw
53 01 070	S 200/5	Madre vite • Vis • Nut-screw	88 50 042	S 170/5	Vite • Vis • Screw	88 50 216	G 10/5	Vite • Vis • Screw
53 01 072	S 200/5	Piatto • Plateau • Plate	88 50 042	S 90/5	Vite • Vis • Screw	88 50 218	S 11/4	Vite • Vis • Screw
53 01 073	S 200/5	Perno • Pivot • Pin	88 50 043	P 20/5	Vite • Vis • Screw	88 50 218	S 21/4	Vite • Vis • Screw
53 01 078	S 200/5	Manovella • Manivelle • Crank	88 50 044	E 50/4	Vite • Vis • Screw	88 50 221	A 10/5	Vite • Vis • Screw
53 05 051	E 30/5	Perno • Pivot • Pin	88 50 044	H 20/5	Vite • Vis • Screw	88 50 221	C 10/5	Vite • Vis • Screw
53 05 051	S 160/5	Perno • Pivot • Pin	88 50 044	P 20/5	Vite • Vis • Screw	88 50 221	C 10/5	Vite • Vis • Screw
53 06 047	F 30/5	Piastra • Plaque • Plate	88 50 045	E 20/5	Vite • Vis • Screw	88 50 221	D 10/5	Vite • Vis • Screw
53 06 048	F 30/5	Appoggio • Appui • Support	88 50 048	S 160/5	Vite • Vis • Screw	88 50 221	E 10/5	Vite • Vis • Screw
53 06 049	F 30/5	Distanziale • Entretoise • Spacer	88 50 055	L 21/5	Vite • Vis • Screw	88 50 221	G 40/5	Vite • Vis • Screw
53 06 049	N 20/5	Distanziale • Entretoise • Spacer	88 50 061	E 30/5	Vite • Vis • Screw	88 50 221	N 10/5	Vite • Vis • Screw
53 07 063	G 40/5	Cassa • Boîte • Casing	88 50 061	S 160/5	Vite • Vis • Screw	88 50 221	N 20/5	Vite • Vis • Screw
53 07 063	G 40/5	Cassa • Boîte • Casing	88 50 065	A 50/4	Vite • Vis • Screw	88 50 221	P 10/5	Vite • Vis • Screw
53 09 006	L 20/1	Piatto • Plateau • Plate	88 50 065	A 50/5	Vite • Vis • Screw	88 50 221	P 10/5	Vite • Vis • Screw
53 09 006	L 20/1	Piatto • Plateau • Plate	88 50 065	A 51/4	Vite • Vis • Screw	88 50 221	P 10/5	Vite • Vis • Screw

Codice Code	Tav. Tab.	Descrizione • Description • Description	Codice Code	Tav. Tab.	Descrizione • Description • Description	Codice Code	Tav. Tab.	Descrizione • Description • Description
88 50 354	G 50/5	Vite • Vis • Screw	88 50 383	A 10/5	Vite • Vis • Screw	88 50 634	G 40/5	Vite • Vis • Screw
88 50 354	G 50/5	Vite • Vis • Screw	88 50 385	A 10/5	Vite • Vis • Screw	88 50 647	F 30/5	Vite • Vis • Screw
88 50 354	H 10/5	Vite • Vis • Screw	88 50 385	A 30/5	Vite • Vis • Screw	88 50 653	F 40/5	Vite • Vis • Screw
88 50 354	H 10/5	Vite • Vis • Screw	88 50 385	S 140/5	Vite • Vis • Screw	88 50 653	G 50/5	Vite • Vis • Screw
88 50 354	N 40/5	Vite • Vis • Screw	88 50 390	A 10/5	Vite • Vis • Screw	88 50 653	N 20/5	Vite • Vis • Screw
88 50 354	P 10/5	Vite • Vis • Screw	88 50 390	A 10/5	Vite • Vis • Screw	88 50 653	N 20/5	Vite • Vis • Screw
88 50 354	P 11/5	Vite • Vis • Screw	88 50 390	A 10/5	Vite • Vis • Screw	88 50 653	N 30/5	Vite • Vis • Screw
88 50 354	P 11/5	Vite • Vis • Screw	88 50 390	A 20/5	Vite • Vis • Screw	88 50 655	D 10/5	Vite • Vis • Screw
88 50 354	P 11/5	Vite • Vis • Screw	88 50 390	A 30/5	Vite • Vis • Screw	88 50 670	F 30/5	Cavallotto • Crampillon • Ubolt
88 50 354	P 30/5	Vite • Vis • Screw	88 50 390	E 10/5	Vite • Vis • Screw	88 50 670	F 30/5	Cavallotto • Crampillon • Ubolt
88 50 354	P 30/5	Vite • Vis • Screw	88 50 390	E 10/5	Vite • Vis • Screw	88 50 670	G 30/5	Cavallotto • Crampillon • Ubolt
88 50 354	P 30/5	Vite • Vis • Screw	88 50 390	E 10/5	Vite • Vis • Screw	88 50 670	G 30/5	Cavallotto • Crampillon • Ubolt
88 50 354	P 40/5	Vite • Vis • Screw	88 50 390	E 10/5	Vite • Vis • Screw	88 50 685	C 10/5	Vite • Vis • Screw
88 50 354	P 60/5	Vite • Vis • Screw	88 50 390	H 10/3	Vite • Vis • Screw	88 50 716	D 10/5	Vite • Vis • Screw
88 50 354	P 60/5	Vite • Vis • Screw	88 50 390	H 10/5	Vite • Vis • Screw	88 50 718	D 10/5	Vite • Vis • Screw
88 50 354	R 10/5	Vite • Vis • Screw	88 50 390	N 10/3	Vite • Vis • Screw	88 50 718	D 10/5	Vite • Vis • Screw
88 50 354	S 100/5	Vite • Vis • Screw	88 50 390	N 10/5	Vite • Vis • Screw	88 50 802	C 10/5	Vite • Vis • Screw
88 50 354	S 100/5	Vite • Vis • Screw	88 50 390	N 30/5	Vite • Vis • Screw	88 50 902	F 20/1	Vite • Vis • Screw
88 50 354	S 180/5	Vite • Vis • Screw	88 50 392	E 20/5	Vite • Vis • Screw	88 50 902	F 20/5	Vite • Vis • Screw
88 50 354	S 180/5	Vite • Vis • Screw	88 50 392	H 10/3	Vite • Vis • Screw	88 51 005	F 30/5	Dado • Ecou • Nut
88 50 354	S 190/4	Vite • Vis • Screw	88 50 392	H 10/5	Vite • Vis • Screw	88 51 005	F 30/5	Dado • Ecou • Nut
88 50 354	S 190/5	Vite • Vis • Screw	88 50 397	G 20/5	Vite • Vis • Screw	88 51 005	G 30/5	Dado • Ecou • Nut
88 50 354	S 70/5	Vite • Vis • Screw	88 50 421	G 10/5	Vite • Vis • Screw	88 51 005	G 30/5	Dado • Ecou • Nut
88 50 354	S 70/5	Vite • Vis • Screw	88 50 463	G 10/5	Vite • Vis • Screw	88 51 005	S 190/4	Dado • Ecou • Nut
88 50 359	B 30/5	Vite • Vis • Screw	88 50 473	E 40/5	Vite • Vis • Screw	88 51 005	S 190/4	Dado • Ecou • Nut
88 50 359	G 30/5	Vite • Vis • Screw	88 50 474	D 11/4	Vite • Vis • Screw	88 51 005	S 190/5	Dado • Ecou • Nut
88 50 362	C 20/5	Vite • Vis • Screw	88 50 474	D 11/5	Vite • Vis • Screw	88 51 005	S 190/5	Dado • Ecou • Nut
88 50 362	F 40/5	Vite • Vis • Screw	88 50 482	G 10/5	Vite • Vis • Screw	88 51 006	E 10/5	Dado • Ecou • Nut
88 50 362	G 50/5	Vite • Vis • Screw	88 50 500	N 20/5	Vite • Vis • Screw	88 51 006	F 30/5	Dado • Ecou • Nut
88 50 362	G 50/5	Vite • Vis • Screw	88 50 511	S 190/4	Vite • Vis • Screw	88 51 006	F 30/5	Dado • Ecou • Nut
88 50 362	P 30/5	Vite • Vis • Screw	88 50 511	S 190/5	Vite • Vis • Screw	88 51 006	F 30/5	Dado • Ecou • Nut
88 50 362	P 60/5	Vite • Vis • Screw	88 50 512	E 10/5	Vite • Vis • Screw	88 51 006	F 30/5	Dado • Ecou • Nut
88 50 364	A 10/5	Vite • Vis • Screw	88 50 512	P 60/5	Vite • Vis • Screw	88 51 006	G 50/5	Dado • Ecou • Nut
88 50 364	A 40/5	Vite • Vis • Screw	88 50 515	F 20/5	Vite • Vis • Screw	88 51 006	P 11/5	Dado • Ecou • Nut
88 50 364	F 30/5	Vite • Vis • Screw	88 50 519	S 190/4	Vite • Vis • Screw	88 51 006	P 20/5	Dado • Ecou • Nut
88 50 364	G 20/5	Vite • Vis • Screw	88 50 519	S 190/5	Vite • Vis • Screw	88 51 006	P 20/5	Dado • Ecou • Nut
88 50 364	G 40/5	Vite • Vis • Screw	88 50 530	N 30/5	Vite • Vis • Screw	88 51 006	P 20/5	Dado • Ecou • Nut
88 50 364	G 40/5	Vite • Vis • Screw	88 50 531	F 20/1	Vite • Vis • Screw	88 51 006	P 41/5	Dado • Ecou • Nut
88 50 364	N 30/5	Vite • Vis • Screw	88 50 531	G 10/1	Vite • Vis • Screw	88 51 006	P 50/5	Dado • Ecou • Nut
88 50 364	P 10/5	Vite • Vis • Screw	88 50 531	N 20/5	Vite • Vis • Screw	88 51 006	P 50/5	Dado • Ecou • Nut
88 50 364	P 11/5	Vite • Vis • Screw	88 50 535	E 10/5	Vite • Vis • Screw	88 51 006	P 60/5	Dado • Ecou • Nut
88 50 364	P 30/5	Vite • Vis • Screw	88 50 535	E 10/5	Vite • Vis • Screw	88 51 006	S 10/4	Dado • Ecou • Nut
88 50 364	R 10/5	Vite • Vis • Screw	88 50 562	C 10/5	Vite • Vis • Screw	88 51 006	S 10/5	Dado • Ecou • Nut
88 50 364	S 140/5	Vite • Vis • Screw	88 50 562	C 20/5	Vite • Vis • Screw	88 51 006	S 11/4	Dado • Ecou • Nut
88 50 374	G 50/5	Vite • Vis • Screw	88 50 563	C 10/5	Vite • Vis • Screw	88 51 006	S 11/5	Dado • Ecou • Nut
88 50 378	A 10/5	Vite • Vis • Screw	88 50 570	F 10/1	Vite • Vis • Screw	88 51 006	S 20/4	Dado • Ecou • Nut
88 50 378	E 20/5	Vite • Vis • Screw	88 50 570	F 10/4	Vite • Vis • Screw	88 51 006	S 20/5	Dado • Ecou • Nut
88 50 378	E 40/5	Vite • Vis • Screw	88 50 570	F 10/5	Vite • Vis • Screw	88 51 006	S 21/4	Dado • Ecou • Nut
88 50 378	N 10/5	Vite • Vis • Screw	88 50 609	S 160/5	Vite • Vis • Screw	88 51 006	S 21/5	Dado • Ecou • Nut

Codice Code	Tav. Tab.	Descrizione • Description • Description	Codice Code	Tav. Tab.	Descrizione • Description • Description	Codice Code	Tav. Tab.	Descrizione • Description • Description
88 56 017	S 70/5	Catena • Chaîne • Chain	88 72 036	S 210/3	Rondella • Rondelle • Washer	88 73 037	S 21/5	Iniettore • Injecteur • Injector
88 56 036	S 202/5	Catena • Chaîne • Chain	88 72 036	S 210/5	Rondella • Rondelle • Washer	88 73 038	S 11/4	Iniettore • Injecteur • Injector
88 56 036	S 202/5	Catena • Chaîne • Chain	88 72 036	S 210/5	Rondella • Rondelle • Washer	88 73 038	S 11/4	Iniettore • Injecteur • Injector
88 57 009	S 90/5	Fune • Cable • Cable	88 72 037	S 160/5	Rondella • Rondelle • Washer	88 73 038	S 11/4	Iniettore • Injecteur • Injector
88 57 035	E 40/5	Fune • Cable • Cable	88 72 037	S 210/3	Rondella • Rondelle • Washer	88 73 038	S 11/4	Iniettore • Injecteur • Injector
88 57 050	S 170/5	Fune • Cable • Cable	88 72 037	S 210/5	Rondella • Rondelle • Washer	88 73 038	S 11/5	Iniettore • Injecteur • Injector
88 57 209	S 90/5	Guaina • Gaine • Sheath	88 72 038	S 160/5	Guarnizione • Joint • Seal	88 73 038	S 21/4	Iniettore • Injecteur • Injector
88 57 222	S 170/5	Guaina • Gaine • Sheath	88 72 038	S 210/3	Guarnizione • Joint • Seal	88 73 038	S 21/4	Iniettore • Injecteur • Injector
88 57 410	R 10/5	Fune • Cable • Cable	88 72 038	S 210/3	Guarnizione • Joint • Seal	88 73 038	S 21/4	Iniettore • Injecteur • Injector
88 57 417	R 10/5	Fune • Cable • Cable	88 72 038	S 210/3	Guarnizione • Joint • Seal	88 73 038	S 21/4	Iniettore • Injecteur • Injector
88 58 016	S 10/4	Pompa • Pompe • Pump	88 72 038	S 210/3	Guarnizione • Joint • Seal	88 73 038	S 21/4	Iniettore • Injecteur • Injector
88 58 016	S 10/5	Pompa • Pompe • Pump	88 72 038	S 210/5	Guarnizione • Joint • Seal	88 73 038	S 21/5	Iniettore • Injecteur • Injector
88 58 016	S 20/4	Pompa • Pompe • Pump	88 72 038	S 210/5	Guarnizione • Joint • Seal	88 73 044	S 11/4	Distributore • Distributeur • Control valve
88 58 016	S 20/5	Pompa • Pompe • Pump	88 72 038	S 210/5	Guarnizione • Joint • Seal	88 73 044	S 11/5	Distributore • Distributeur • Control valve
88 59 257	S 210/3	Martinetto • Verin • Ram	88 72 038	S 210/5	Guarnizione • Joint • Seal	88 73 044	S 21/4	Distributore • Distributeur • Control valve
88 59 257	S 210/5	Martinetto • Verin • Ram	88 72 169	D 10/5	Rondella • Rondelle • Washer	88 73 044	S 21/5	Distributore • Distributeur • Control valve
88 59 706	S 160/5	Martinetto • Verin • Ram	88 72 171	D 10/5	Rondella • Rondelle • Washer	88 73 046	S 11/4	Distributore • Distributeur • Control valve
88 60 101	B 10/5	Spina • Goupille • Pin	88 72 172	D 10/5	Rondella • Rondelle • Washer	88 73 046	S 11/4	Distributore • Distributeur • Control valve
88 60 101	R 10/5	Spina • Goupille • Pin	88 72 174	D 10/5	Spessore • Epaisseur • Shim	88 73 046	S 21/4	Distributore • Distributeur • Control valve
88 62 008	H 30/5	Catena • Chaîne • Chain	88 72 175	D 10/5	Spessore • Epaisseur • Shim	88 73 046	S 21/4	Distributore • Distributeur • Control valve
88 62 010	H 30/5	Catena • Chaîne • Chain	88 72 208	D 10/5	Spessore • Epaisseur • Shim	88 73 047	S 11/4	Distributore • Distributeur • Control valve
88 62 011	H 30/5	Catena • Chaîne • Chain	88 72 209	D 10/5	Spessore • Epaisseur • Shim	88 73 047	S 11/4	Distributore • Distributeur • Control valve
88 62 012	H 30/5	Catena • Chaîne • Chain	88 73 021	S 10/4	Doppio cono • Cône double • Double cone	88 73 047	S 21/4	Distributore • Distributeur • Control valve
88 62 220	B 10/5	Catena • Chaîne • Chain	88 73 021	S 10/4	Doppio cono • Cône double • Double cone	88 73 047	S 21/4	Distributore • Distributeur • Control valve
88 62 220	N 20/1	Catena • Chaîne • Chain	88 73 021	S 10/5	Doppio cono • Cône double • Double cone	88 73 047	S 21/4	Distributore • Distributeur • Control valve
88 62 427	B 10/5	Catena • Chaîne • Chain	88 73 021	S 10/5	Doppio cono • Cône double • Double cone	88 73 052	S 11/4	Prolunga • Rallonge • Extension
88 62 430	B 20/5	Catena • Chaîne • Chain	88 73 021	S 20/4	Doppio cono • Cône double • Double cone	88 73 052	S 11/5	Prolunga • Rallonge • Extension
88 62 430	B 20/5	Catena • Chaîne • Chain	88 73 021	S 20/4	Doppio cono • Cône double • Double cone	88 73 052	S 21/4	Prolunga • Rallonge • Extension
88 62 430	H 20/5	Catena • Chaîne • Chain	88 73 021	S 20/5	Doppio cono • Cône double • Double cone	88 73 052	S 21/4	Prolunga • Rallonge • Extension
88 63 039	S 210/3	Valvola • Soupape • Valve	88 73 021	S 20/5	Doppio cono • Cône double • Double cone	88 73 052	S 21/4	Prolunga • Rallonge • Extension
88 63 039	S 210/5	Valvola • Soupape • Valve	88 73 024	S 11/4	Anello • Bague • Ring	88 73 052	S 21/5	Prolunga • Rallonge • Extension
88 64 010	S 11/4	Filtro • Filtre • Filter	88 73 024	S 11/5	Anello • Bague • Ring	88 73 052	S 21/5	Prolunga • Rallonge • Extension
88 64 010	S 11/5	Filtro • Filtre • Filter	88 73 024	S 21/4	Anello • Bague • Ring	88 73 053	S 11/4	Riduzione • Réduction • Reducer
88 64 010	S 21/4	Filtro • Filtre • Filter	88 73 024	S 21/5	Anello • Bague • Ring	88 73 053	S 11/5	Riduzione • Réduction • Reducer
88 64 010	S 21/5	Filtro • Filtre • Filter	88 73 032	S 11/4	Tappo • Bouchon • Plug	88 73 053	S 21/4	Riduzione • Réduction • Reducer
88 66 004	L 20/1	Disco attrito • Disque de retenue • Retaining disk	88 73 032	S 11/5	Tappo • Bouchon • Plug	88 73 053	S 21/5	Riduzione • Réduction • Reducer
88 66 004	L 20/1	Disco attrito • Disque de retenue • Retaining disk	88 73 032	S 21/4	Tappo • Bouchon • Plug	88 73 062	S 10/4	Raccordo • Raccord • Connection
88 66 004	L 20/1	Disco attrito • Disque de retenue • Retaining disk	88 73 032	S 21/5	Tappo • Bouchon • Plug	88 73 062	S 10/5	Raccordo • Raccord • Connection
88 66 004	L 20/1	Disco attrito • Disque de retenue • Retaining disk	88 73 037	S 11/4	Iniettore • Injecteur • Injector	88 73 062	S 20/4	Raccordo • Raccord • Connection
88 66 004	L 20/1	Disco attrito • Disque de retenue • Retaining disk	88 73 037	S 11/4	Iniettore • Injecteur • Injector	88 73 062	S 20/5	Raccordo • Raccord • Connection
88 66 007	N 20/5	Ferodo • Ferodo • Brake lining	88 73 037	S 11/5	Iniettore • Injecteur • Injector	88 73 063	S 10/4	Raccordo • Raccord • Connection
88 66 007	N 20/5	Ferodo • Ferodo • Brake lining	88 73 037	S 11/5	Iniettore • Injecteur • Injector	88 73 063	S 10/5	Raccordo • Raccord • Connection
88 66 014	N 20/1	Guarnizione • Joint • Seal	88 73 037	S 21/4	Iniettore • Injecteur • Injector	88 73 063	S 20/4	Raccordo • Raccord • Connection
88 68 033	H 30/5	Chiavetta • Clè • Key	88 73 037	S 21/4	Iniettore • Injecteur • Injector	88 73 063	S 20/5	Raccordo • Raccord • Connection
88 68 046	C 10/5	Chiavetta • Clè • Key	88 73 037	S 21/4	Iniettore • Injecteur • Injector	88 73 066	S 11/4	Raccordo • Raccord • Connection
88 68 053	H 20/5	Linguetta • Langnette • Key	88 73 037	S 21/4	Iniettore • Injecteur • Injector	88 73 066	S 11/5	Raccordo • Raccord • Connection
88 72 032	S 210/3	Rondella • Rondelle • Washer	88 73 037	S 21/5	Iniettore • Injecteur • Injector	88 73 066	S 21/4	Raccordo • Raccord • Connection
88 72 032	S 210/5	Rondella • Rondelle • Washer	88 73 037	S 21/5	Iniettore • Injecteur • Injector	88 73 066	S 21/5	Raccordo • Raccord • Connection
88 72 036	S 160/5	Rondella • Rondelle • Washer	88 73 037	S 21/5	Iniettore • Injecteur • Injector	88 73 067	S 11/4	Raccordo • Raccord • Connection

Codice Code	Tav. Tab.	Descrizione • Description • Description	Codice Code	Tav. Tab.	Descrizione • Description • Description	Codice Code	Tav. Tab.	Descrizione • Description • Description
88 73 067	S 11/5	Raccordo • Raccord • Connection	88 75 359	A 51/5	Cerchio • Jante • Rim	88 76 218	G 10/5	Molla • Ressort • Spring
88 73 067	S 21/4	Raccordo • Raccord • Connection	88 75 360	A 50/5	Cerchio • Jante • Rim	88 76 252	S 130/5	Molla • Ressort • Spring
88 73 067	S 21/4	Raccordo • Raccord • Connection	88 75 404	A 50/4	Dado • Ecrou • Nut	88 76 261	A 20/5	Molla • Ressort • Spring
88 73 067	S 21/5	Raccordo • Raccord • Connection	88 75 404	A 50/5	Dado • Ecrou • Nut	88 76 261	A 20/5	Molla • Ressort • Spring
88 73 067	S 21/5	Raccordo • Raccord • Connection	88 75 404	A 51/4	Dado • Ecrou • Nut	88 76 261	A 20/5	Molla • Ressort • Spring
88 73 082	S 11/5	Distributore • Distributeur • Control valve	88 75 404	A 51/5	Dado • Ecrou • Nut	88 76 261	E 30/5	Molla • Ressort • Spring
88 73 082	S 21/5	Distributore • Distributeur • Control valve	88 75 416	A 50/4	Colonna • Colonne • Column	88 76 261	E 30/5	Molla • Ressort • Spring
88 73 092	S 11/4	Terminale • Terminal • End piece	88 75 416	A 50/5	Colonna • Colonne • Column	88 76 261	S 160/5	Molla • Ressort • Spring
88 73 092	S 11/5	Terminale • Terminal • End piece	88 75 416	A 51/4	Colonna • Colonne • Column	88 76 278	E 20/5	Molla • Ressort • Spring
88 73 092	S 21/4	Terminale • Terminal • End piece	88 75 416	A 51/5	Colonna • Colonne • Column	88 76 279	E 20/5	Molla • Ressort • Spring
88 73 092	S 21/5	Terminale • Terminal • End piece	88 75 420	S 170/5	Colonna • Colonne • Column	88 76 281	B 30/5	Molla • Ressort • Spring
88 73 093	S 11/4	Terminale • Terminal • End piece	88 76 003	N 30/5	Molla • Ressort • Spring	88 76 282	F 20/1	Molla • Ressort • Spring
88 73 093	S 11/4	Terminale • Terminal • End piece	88 76 004	G 10/1	Molla • Ressort • Spring	88 76 282	N 40/5	Molla • Ressort • Spring
88 73 093	S 21/4	Terminale • Terminal • End piece	88 76 004	N 20/5	Molla • Ressort • Spring	88 76 287	A 40/5	Molla • Ressort • Spring
88 73 093	S 21/4	Terminale • Terminal • End piece	88 76 008	N 20/5	Molla • Ressort • Spring	88 76 287	A 40/5	Molla • Ressort • Spring
88 74 004	S 160/5	Riduzione • Réduction • Reducer	88 76 009	N 20/1	Molla • Ressort • Spring	88 76 293	E 20/5	Molla • Ressort • Spring
88 74 004	S 210/3	Riduzione • Réduction • Reducer	88 76 015	N 20/5	Molla • Ressort • Spring	88 76 308	D 11/4	Molla • Ressort • Spring
88 74 004	S 210/5	Riduzione • Réduction • Reducer	88 76 041	N 30/5	Molla • Ressort • Spring	88 76 308	D 11/5	Molla • Ressort • Spring
88 74 033	S 210/3	Vite • Vis • Screw	88 76 057	N 40/5	Molla • Ressort • Spring	88 76 435	F 30/5	Molla • Ressort • Spring
88 74 033	S 210/5	Vite • Vis • Screw	88 76 107	N 20/5	Molla • Ressort • Spring	88 76 442	E 20/5	Molla • Ressort • Spring
88 74 035	S 210/3	Vite • Vis • Screw	88 76 108	A 10/5	Molla • Ressort • Spring	88 76 447	F 30/5	Guida • Guide • Guide
88 74 035	S 210/5	Vite • Vis • Screw	88 76 109	E 40/5	Molla • Ressort • Spring	88 76 448	F 30/5	Guida • Guide • Guide
88 74 046	S 210/3	Prolunga • Rallonge • Extension	88 76 109	E 40/5	Molla • Ressort • Spring	88 76 630	L 21/5	Molla • Ressort • Spring
88 74 046	S 210/5	Prolunga • Rallonge • Extension	88 76 111	F 10/1	Molla • Ressort • Spring	88 77 064	S 210/3	Tube • Tuyau • Hose
88 74 105	S 160/5	Innesto rapido • Attache rapide • Quick connection	88 76 111	F 10/4	Molla • Ressort • Spring	88 77 064	S 210/5	Tube • Tuyau • Hose
88 74 105	S 210/3	Innesto rapido • Attache rapide • Quick connection	88 76 111	F 10/5	Molla • Ressort • Spring	88 77 114	S 160/5	Fascetta • Collier • Clamp
88 74 105	S 210/5	Innesto rapido • Attache rapide • Quick connection	88 76 113	E 10/5	Molla • Ressort • Spring	88 77 114	S 160/5	Fascetta • Collier • Clamp
88 74 109	S 210/5	Riduzione • Réduction • Reducer	88 76 113	P 50/5	Molla • Ressort • Spring	88 77 114	S 210/3	Fascetta • Collier • Clamp
88 74 162	S 210/3	Raccordo • Raccord • Connection	88 76 113	P 50/5	Molla • Ressort • Spring	88 77 114	S 210/5	Fascetta • Collier • Clamp
88 74 162	S 210/5	Raccordo • Raccord • Connection	88 76 122	L 20/1	Molla • Ressort • Spring	88 77 115	S 11/4	Fascetta • Collier • Clamp
88 74 202	D 10/5	Tappo • Bouchon • Plug	88 76 123	L 20/1	Molla • Ressort • Spring	88 77 115	S 11/5	Fascetta • Collier • Clamp
88 74 225	S 160/5	Tappo • Bouchon • Plug	88 76 134	F 30/5	Molla • Ressort • Spring	88 77 115	S 21/4	Fascetta • Collier • Clamp
88 74 225	S 210/3	Tappo • Bouchon • Plug	88 76 159	P 20/5	Molla • Ressort • Spring	88 77 115	S 21/5	Fascetta • Collier • Clamp
88 74 225	S 210/5	Tappo • Bouchon • Plug	88 76 162	N 20/1	Molla • Ressort • Spring	88 77 117	S 190/4	Fascetta • Collier • Clamp
88 74 225	S 210/5	Tappo • Bouchon • Plug	88 76 163	A 20/5	Molla • Ressort • Spring	88 77 117	S 190/4	Fascetta • Collier • Clamp
88 74 232	S 160/5	Protezione • Protection • Guard	88 76 169	S 170/5	Molla • Ressort • Spring	88 77 117	S 190/4	Fascetta • Collier • Clamp
88 74 232	S 210/3	Protezione • Protection • Guard	88 76 189	H 20/5	Molla • Ressort • Spring	88 77 117	S 190/5	Fascetta • Collier • Clamp
88 74 232	S 210/5	Protezione • Protection • Guard	88 76 196	L 20/1	Molla • Ressort • Spring	88 77 118	S 190/5	Fascetta • Collier • Clamp
88 74 252	S 160/5	Strozzatore • Etrangleur • Restrictor	88 76 196	L 20/1	Molla • Ressort • Spring	88 77 118	S 190/5	Fascetta • Collier • Clamp
88 74 252	S 210/3	Strozzatore • Etrangleur • Restrictor	88 76 205	F 10/1	Molla • Ressort • Spring	88 77 402	S 10/4	Tube • Tuyau • Hose
88 74 252	S 210/5	Strozzatore • Etrangleur • Restrictor	88 76 205	F 10/4	Molla • Ressort • Spring	88 77 402	S 10/5	Tube • Tuyau • Hose
88 74 264	S 210/5	Protezione • Protection • Guard	88 76 205	F 10/5	Molla • Ressort • Spring	88 77 402	S 20/4	Tube • Tuyau • Hose
88 75 018	S 120/5	Ruota • Roue • Wheel	88 76 205	G 10/1	Molla • Ressort • Spring	88 77 402	S 20/5	Tube • Tuyau • Hose
88 75 308	S 50/5	Cerchio • Jante • Rim	88 76 205	G 10/5	Molla • Ressort • Spring	88 77 407	S 10/4	Tube • Tuyau • Hose
88 75 340	A 51/4	Cerchio • Jante • Rim	88 76 206	E 10/5	Molla • Ressort • Spring	88 77 407	S 10/5	Tube • Tuyau • Hose
88 75 340	A 51/4	Cerchio • Jante • Rim	88 76 207	E 40/5	Molla • Ressort • Spring	88 77 407	S 20/4	Tube • Tuyau • Hose
88 75 341	A 50/4	Cerchio • Jante • Rim	88 76 213	G 40/5	Molla • Ressort • Spring	88 77 407	S 20/5	Tube • Tuyau • Hose
88 75 341	A 50/4	Cerchio • Jante • Rim	88 76 214	P 40/5	Molla • Ressort • Spring	88 77 410	S 10/5	Tube • Tuyau • Hose
88 75 349	S 50/5	Cerchio • Jante • Rim	88 76 218	G 10/1	Molla • Ressort • Spring	88 77 410	S 20/5	Tube • Tuyau • Hose

Codice Code	Tav. Tab.	Descrizione • Description • Description	Codice Code	Tav. Tab.	Descrizione • Description • Description	Codice Code	Tav. Tab.	Descrizione • Description • Description
88 77 412	S 10/4	Tubo • Tuyau • Hose	88 80 013	G 10/5	Bronzina • Coussinet • Bushing	88 80 214	G 30/5	Boccola • Douille • Bushing
88 77 412	S 20/4	Tubo • Tuyau • Hose	88 80 013	G 10/5	Bronzina • Coussinet • Bushing	88 80 214	G 30/5	Boccola • Douille • Bushing
88 77 415	S 10/4	Tubo • Tuyau • Hose	88 80 013	N 20/5	Bronzina • Coussinet • Bushing	88 80 217	S 120/5	Boccola • Douille • Bushing
88 77 415	S 10/5	Tubo • Tuyau • Hose	88 80 013	N 20/5	Bronzina • Coussinet • Bushing	88 80 220	N 20/1	Cuscinetto • Roulement • Bearing
88 77 415	S 20/4	Tubo • Tuyau • Hose	88 80 015	B 10/5	Bronzina • Coussinet • Bushing	88 80 303	B 10/5	Boccola • Douille • Bushing
88 77 415	S 20/5	Tubo • Tuyau • Hose	88 80 071	B 30/5	Bronzina • Coussinet • Bushing	88 80 303	B 10/5	Boccola • Douille • Bushing
88 77 422	S 10/4	Tubo • Tuyau • Hose	88 80 071	B 30/5	Bronzina • Coussinet • Bushing	88 80 303	B 10/5	Boccola • Douille • Bushing
88 77 422	S 10/5	Tubo • Tuyau • Hose	88 80 087	D 11/4	Bronzina • Coussinet • Bushing	88 80 321	H 30/5	Boccola • Douille • Bushing
88 77 422	S 20/4	Tubo • Tuyau • Hose	88 80 087	D 11/4	Bronzina • Coussinet • Bushing	88 80 321	H 30/5	Boccola • Douille • Bushing
88 77 422	S 20/5	Tubo • Tuyau • Hose	88 80 087	D 11/5	Bronzina • Coussinet • Bushing	88 80 322	D 11/4	Boccola • Douille • Bushing
88 77 428	S 10/4	Tubo • Tuyau • Hose	88 80 087	D 11/5	Bronzina • Coussinet • Bushing	88 80 322	D 11/4	Boccola • Douille • Bushing
88 77 428	S 10/5	Tubo • Tuyau • Hose	88 80 100	E 10/5	Boccola • Douille • Bushing	88 80 322	D 11/5	Boccola • Douille • Bushing
88 77 428	S 20/4	Tubo • Tuyau • Hose	88 80 100	G 10/1	Boccola • Douille • Bushing	88 80 322	D 11/5	Boccola • Douille • Bushing
88 77 428	S 20/5	Tubo • Tuyau • Hose	88 80 100	N 20/5	Boccola • Douille • Bushing	88 80 407	H 20/5	Boccola • Douille • Bushing
88 77 430	S 10/4	Tubo • Tuyau • Hose	88 80 101	F 20/5	Boccola • Douille • Bushing	88 80 407	H 20/5	Boccola • Douille • Bushing
88 77 430	S 10/5	Tubo • Tuyau • Hose	88 80 101	G 10/1	Boccola • Douille • Bushing	88 80 407	H 20/5	Boccola • Douille • Bushing
88 77 430	S 20/4	Tubo • Tuyau • Hose	88 80 101	G 20/5	Boccola • Douille • Bushing	88 80 408	H 30/5	Bronzina • Coussinet • Bushing
88 77 430	S 20/5	Tubo • Tuyau • Hose	88 80 101	N 20/5	Boccola • Douille • Bushing	88 80 408	H 30/5	Bronzina • Coussinet • Bushing
88 77 431	S 10/4	Tubo • Tuyau • Hose	88 80 103	N 30/5	Boccola • Douille • Bushing	88 80 422	N 10/1	Boccola • Douille • Bushing
88 77 431	S 10/5	Tubo • Tuyau • Hose	88 80 104	F 20/1	Boccola • Douille • Bushing	88 80 431	N 10/5	Boccola • Douille • Bushing
88 77 435	S 11/4	Tubo • Tuyau • Hose	88 80 104	F 20/5	Boccola • Douille • Bushing	88 80 502	S 30/5	Bronzina • Coussinet • Bushing
88 77 435	S 11/4	Tubo • Tuyau • Hose	88 80 105	E 40/5	Boccola • Douille • Bushing	88 80 506	H 20/5	Bronzina • Coussinet • Bushing
88 77 435	S 11/5	Tubo • Tuyau • Hose	88 80 105	F 20/1	Boccola • Douille • Bushing	88 80 506	H 20/5	Bronzina • Coussinet • Bushing
88 77 435	S 11/5	Tubo • Tuyau • Hose	88 80 105	N 30/5	Boccola • Douille • Bushing	88 80 507	H 20/5	Bronzina • Coussinet • Bushing
88 77 435	S 21/4	Tubo • Tuyau • Hose	88 80 105	P 20/5	Boccola • Douille • Bushing	88 80 507	H 20/5	Bronzina • Coussinet • Bushing
88 77 435	S 21/4	Tubo • Tuyau • Hose	88 80 105	P 20/5	Boccola • Douille • Bushing	88 80 507	H 30/5	Bronzina • Coussinet • Bushing
88 77 435	S 21/5	Tubo • Tuyau • Hose	88 80 111	N 40/5	Boccola • Douille • Bushing	88 80 508	H 30/5	Bronzina • Coussinet • Bushing
88 77 435	S 21/5	Tubo • Tuyau • Hose	88 80 112	G 30/5	Boccola • Douille • Bushing	88 80 508	H 30/5	Bronzina • Coussinet • Bushing
88 77 524	S 160/5	Tubo flessibile • Tuyau flexible • Flexible tube	88 80 112	G 30/5	Boccola • Douille • Bushing	88 80 508	H 30/5	Bronzina • Coussinet • Bushing
88 77 524	S 160/5	Tubo flessibile • Tuyau flexible • Flexible tube	88 80 112	S 170/5	Boccola • Douille • Bushing	88 80 510	N 20/1	Boccola • Douille • Bushing
88 77 547	S 160/5	Tubo flessibile • Tuyau flexible • Flexible tube	88 80 123	P 50/5	Boccola • Douille • Bushing	88 80 510	N 20/1	Boccola • Douille • Bushing
88 77 554	S 210/3	Tubo • Tuyau • Hose	88 80 124	P 40/5	Boccola • Douille • Bushing	88 80 511	C 10/5	Bronzina • Coussinet • Bushing
88 77 554	S 210/5	Tubo • Tuyau • Hose	88 80 129	P 20/5	Boccola • Douille • Bushing	88 80 511	C 10/5	Bronzina • Coussinet • Bushing
88 80 005	G 10/1	Bronzina • Coussinet • Bushing	88 80 200	F 30/5	Boccola • Douille • Bushing	88 80 511	N 20/1	Bronzina • Coussinet • Bushing
88 80 005	G 10/5	Bronzina • Coussinet • Bushing	88 80 200	F 30/5	Boccola • Douille • Bushing	88 80 512	A 20/5	Bronzina • Coussinet • Bushing
88 80 006	H 30/5	Bronzina • Coussinet • Bushing	88 80 200	F 30/5	Boccola • Douille • Bushing	88 80 512	A 20/5	Bronzina • Coussinet • Bushing
88 80 007	N 10/1	Bronzina • Coussinet • Bushing	88 80 205	G 40/5	Boccola • Douille • Bushing	88 80 514	G 30/5	Bronzina • Coussinet • Bushing
88 80 007	N 10/1	Bronzina • Coussinet • Bushing	88 80 206	G 10/1	Boccola • Douille • Bushing	88 80 514	G 30/5	Bronzina • Coussinet • Bushing
88 80 007	N 10/1	Bronzina • Coussinet • Bushing	88 80 206	G 10/5	Boccola • Douille • Bushing	88 80 514	S 170/5	Bronzina • Coussinet • Bushing
88 80 008	E 40/5	Bronzina • Coussinet • Bushing	88 80 207	G 10/1	Boccola • Douille • Bushing	88 82 050	R 10/5	Cuneo • Coin • Wedge
88 80 011	N 10/3	Bronzina • Coussinet • Bushing	88 80 207	G 10/5	Boccola • Douille • Bushing	88 83 040	S 200/5	Cappuccio • Capuchon • Cap
88 80 011	N 10/5	Bronzina • Coussinet • Bushing	88 80 208	G 10/1	Boccola • Douille • Bushing	88 83 041	A 20/5	Cappuccio • Capuchon • Cap
88 80 012	G 10/5	Bronzina • Coussinet • Bushing	88 80 208	G 10/1	Boccola • Douille • Bushing	88 85 004	L 10/3	Crociera • Croisillon • Cross member
88 80 012	N 20/5	Bronzina • Coussinet • Bushing	88 80 208	G 10/1	Boccola • Douille • Bushing	88 85 004	L 10/3	Crociera • Croisillon • Cross member
88 80 012	N 20/5	Bronzina • Coussinet • Bushing	88 80 208	G 10/5	Boccola • Douille • Bushing	88 85 004	L 10/5	Crociera • Croisillon • Cross member
88 80 012	N 20/5	Bronzina • Coussinet • Bushing	88 80 208	G 10/5	Boccola • Douille • Bushing	88 85 004	L 10/5	Crociera • Croisillon • Cross member
88 80 013	E 20/5	Bronzina • Coussinet • Bushing	88 80 208	G 10/5	Boccola • Douille • Bushing	88 85 012	E 50/4	Crociera • Croisillon • Cross member
88 80 013	G 10/1	Bronzina • Coussinet • Bushing	88 80 211	G 10/1	Boccola • Douille • Bushing	88 85 013	S 201/5	Crociera completa • Croisillon complet • Complete cross member
88 80 013	G 10/1	Bronzina • Coussinet • Bushing	88 80 211	G 10/5	Boccola • Douille • Bushing			

Codice Code	Tav. Tab.	Descrizione • Description • Description	Codice Code	Tav. Tab.	Descrizione • Description • Description	Codice Code	Tav. Tab.	Descrizione • Description • Description
88 85 013	S 201/5	Crociera completa • Croisillon complet • Complete cross member	88 89 253	R 30/5	Decalcomania • Decalcomanie • Transfer			
88 86 002	S 190/4	Catadiottro • Catadioptrre • Rear-reflector	88 89 282	R 31/5	Decalcomania • Decalcomanie • Transfer			
88 86 002	S 190/4	Catadiottro • Catadioptrre • Rear-reflector	88 89 283	R 31/5	Decalcomania • Decalcomanie • Transfer			
88 86 002	S 190/4	Catadiottro • Catadioptrre • Rear-reflector	88 89 285	R 31/5	Decalcomania • Decalcomanie • Transfer			
88 86 002	S 190/5	Catadiottro • Catadioptrre • Rear-reflector	88 89 286	R 31/5	Decalcomania • Decalcomanie • Transfer			
88 86 002	S 190/5	Catadiottro • Catadioptrre • Rear-reflector	88 89 341	R 20/5	Decalcomania • Decalcomanie • Transfer			
88 86 002	S 190/5	Catadiottro • Catadioptrre • Rear-reflector	88 89 377	R 31/5	Decalcomania • Decalcomanie • Transfer			
88 86 003	S 190/4	Catadiottro • Catadioptrre • Rear-reflector	88 89 386	R 31/5	Decalcomania • Decalcomanie • Transfer			
88 86 003	S 190/5	Catadiottro • Catadioptrre • Rear-reflector	88 89 390	R 31/5	Decalcomania • Decalcomanie • Transfer			
88 86 004	S 190/4	Catadiottro • Catadioptrre • Rear-reflector	88 89 391	R 31/5	Decalcomania • Decalcomanie • Transfer			
88 86 202	S 170/5	Collare • Collier • Collar	88 89 394	R 31/5	Decalcomania • Decalcomanie • Transfer			
88 86 203	S 10/4	Collare • Collier • Collar	88 89 408	R 30/5	Decalcomania • Decalcomanie • Transfer			
88 86 203	S 10/5	Collare • Collier • Collar	88 89 630	R 20/5	Decalcomania • Decalcomanie • Transfer			
88 86 203	S 20/4	Collare • Collier • Collar	88 89 864	R 30/5	Decalcomania • Decalcomanie • Transfer			
88 86 203	S 20/5	Collare • Collier • Collar	88 89 864	S 110/5	Decalcomania • Decalcomanie • Transfer			
88 86 204	S 170/5	Collare • Collier • Collar	88 89 864	S 130/5	Decalcomania • Decalcomanie • Transfer			
88 86 204	S 190/4	Collare • Collier • Collar	88 89 864	S 50/5	Decalcomania • Decalcomanie • Transfer			
88 86 204	S 190/5	Collare • Collier • Collar	88 89 864	S 50/5	Decalcomania • Decalcomanie • Transfer			
88 86 222	S 160/5	Collare • Collier • Collar	88 89 988	R 30/5	Decalcomania • Decalcomanie • Transfer			
88 86 223	S 160/5	Collare • Collier • Collar	88 89 989	R 30/5	Decalcomania • Decalcomanie • Transfer			
88 89 059	R 30/5	Decalcomania • Decalcomanie • Transfer	88 89 990	R 30/5	Decalcomania • Decalcomanie • Transfer			
88 89 068	R 30/5	Decalcomania • Decalcomanie • Transfer	88 89 B77	R 31/5	Decalcomania • Decalcomanie • Transfer			
88 89 082	R 30/5	Decalcomania • Decalcomanie • Transfer	89 02 118	P 11/5	Boccola • Douille • Bushing			
88 89 156	R 20/5	Decalcomania • Decalcomanie • Transfer	89 02 118	S 190/5	Boccola • Douille • Bushing			
88 89 157	R 20/5	Decalcomania • Decalcomanie • Transfer	98 20 078	S 90/5	Bollettino • Bulletin • Bulletin			
88 89 158	R 20/5	Decalcomania • Decalcomanie • Transfer	98 20 205	S 110/4	Bollettino • Bulletin • Bulletin			
88 89 159	R 20/5	Decalcomania • Decalcomanie • Transfer	98 20 205	S 110/5	Bollettino • Bulletin • Bulletin			
88 89 160	R 20/5	Decalcomania • Decalcomanie • Transfer	98 20 234	S 160/5	Bollettino • Bulletin • Bulletin			
88 89 161	R 20/5	Decalcomania • Decalcomanie • Transfer	98 20 278	S 190/4	Catalogo • Catalogue • Catalogue			
88 89 162	R 20/5	Decalcomania • Decalcomanie • Transfer	98 20 278	S 190/5	Catalogo • Catalogue • Catalogue			
88 89 163	R 20/5	Decalcomania • Decalcomanie • Transfer	98 20 360	S 100/5	Istruzioni • Instructions • Instructions			
88 89 164	R 20/5	Decalcomania • Decalcomanie • Transfer	98 20 360	S 180/5	Istruzioni • Instructions • Instructions			
88 89 165	R 20/5	Decalcomania • Decalcomanie • Transfer	98 20 360	S 70/5	Istruzioni • Instructions • Instructions			
88 89 166	R 30/5	Decalcomania • Decalcomanie • Transfer	98 20 381	S 210/3	Bollettino • Bulletin • Bulletin			
88 89 167	R 20/5	Decalcomania • Decalcomanie • Transfer	98 20 589	R 10/5	Decalcomania • Decalcomanie • Transfer			
88 89 168	R 20/5	Decalcomania • Decalcomanie • Transfer	98 20 594	R 10/5	Manuale d'uso • Manuel d'utilisation • Operation manual			
88 89 169	R 20/5	Adesivo • Adhésif • Adhesive	98 20 622	S 210/5	Bollettino • Bulletin • Bulletin			
88 89 177	R 30/5	Decalcomania • Decalcomanie • Transfer						
88 89 180	R 20/5	Decalcomania • Decalcomanie • Transfer						
88 89 182	R 20/5	Decalcomania • Decalcomanie • Transfer						
88 89 183	R 20/5	Decalcomania • Decalcomanie • Transfer						
88 89 185	R 20/5	Decalcomania • Decalcomanie • Transfer						
88 89 188	R 20/5	Decalcomania • Decalcomanie • Transfer						
88 89 191	R 30/5	Decalcomania • Decalcomanie • Transfer						
88 89 196	R 30/5	Decalcomania • Decalcomanie • Transfer						
88 89 197	R 30/5	Decalcomania • Decalcomanie • Transfer						
88 89 198	R 20/5	Decalcomania • Decalcomanie • Transfer						
88 89 199	R 30/5	Decalcomania • Decalcomanie • Transfer						
88 89 216	S 200/5	Decalcomania • Decalcomanie • Transfer						